

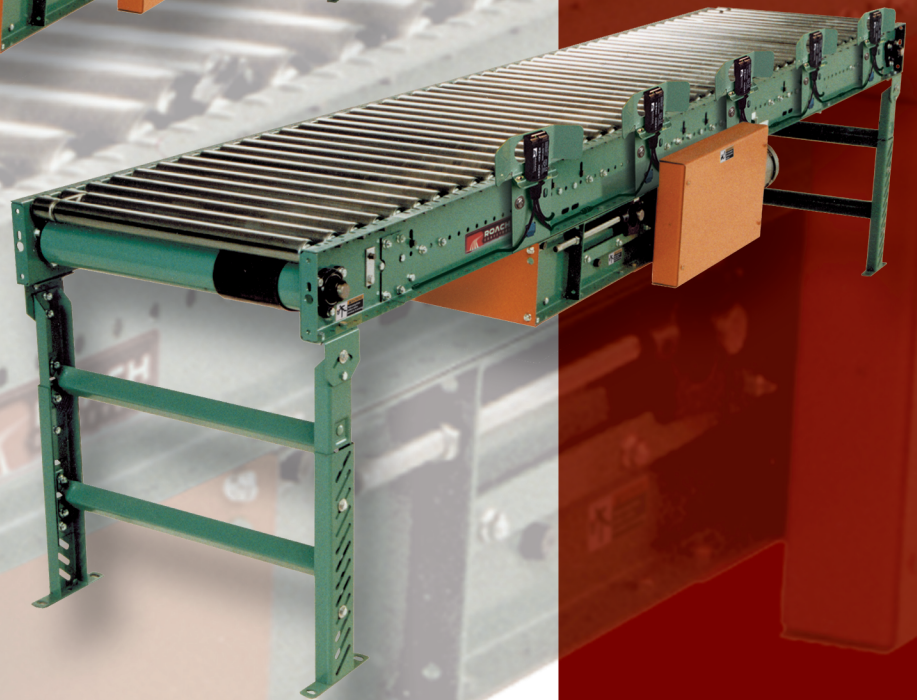

OWNER'S MANUAL



Zero Pressure Accumulators

Models 196ZPA • SZ196ZPA

DO NOT OPERATE BEFORE READING THIS HANDBOOK
KEEP IN A SAFE PLACE – DO NOT DISCARD

TECH HANDBOOK FOR 196ZPA & SZ196ZPA

TABLE OF CONTENTS

TECH HANDBOOK FOR 196ZPA & SZ196ZPA.....	2	-Pop Out Rollers and Installation of Tread Rollers.....	14
-Caution Labels.....	2	-Erratic Tracking at Start-Up.....	15
CAUTIONS, WARNINGS AND HAZARDS.....	3	-Advanced Tracking Adjustments.....	15
-Introduction.....	3	TECHNICAL - STANDARD 196ZPA OPERATION.....	16
-Cautions, Warnings and Hazards.....	3	-Standard 196ZPA Accumulation Operation.....	16
SAFETY INFORMATION.....	4	-Pneumatic Plumbing for Standard 196ZPA Accumulation.....	16
-Important Safety Guidelines.....	4	-Pneumatic Plumbing for Brake Assembly in Discharge Zone.....	17
-Understanding Pop Out Rollers.....	4	-Pneumatic Plumbing for Solenoid in Discharge Zone.....	17
RECEIVING AND INSPECTION.....	5	TECHNICAL - OPTIONAL ZONE SINGULATION OPERATION.....	18
-Shortages, Damages and Return Authorizations.....	5	-Optional Zone Singulation Accumulation.....	18
-Uncrating and Storage.....	5	-Pneumatic Plumbing for Zone Singulation.....	18
GENERAL INSTALLATION INFORMATION.....	6	-Pneumatic Plumbing for Brake Assembly in Discharge Zone.....	19
-Couplings / Attaching Bed Sections.....	6	-Pneumatic Plumbing for Solenoid in Discharge Zone.....	19
-Unit Squareness.....	6	TECHNICAL - SMART ZONE®.....	20
-Squaring Bed Sections.....	7	-Smart Zone® Operation.....	20
-Identifying / Installing Permanent Floor Supports.....	7	-Smart Zone® Details.....	20
KNEE BRACES, CASTERS AND CEILING HANGERS.....	8	-Smart Zone® Off-loading.....	21
-Installing Knee braces and Casters.....	8	-Smart Zone® Slug Release Off-loading / Slug Loading.....	21
-Installation of Ceiling Hangers.....	8	-Models up to 50' W/ Discharge Power Supply (Smart Zone®).....	22
UNDERTRUSSING AND POLYTIER SUPPORTS.....	9	-Smart Zone® Power Supply and Photo Sensor Details.....	22
-Installation of Undertrussing.....	9	-Models up to 100' W/ Intermediate Power Supply (Smart Zone®).....	23
-Installation of Polytier Supports.....	9	-Smart Zone® Operator-Controlled Work Zones (Optional).....	23
INSTALLATION OF BELTING.....	10	MAINTENANCE SAFETY PRECAUTIONS.....	24
-Belt Connections.....	10	-Before Performing Maintenance.....	24
-Maintaining Proper Belt Tension.....	10	-Maintenance and Follow-Up Details.....	24
BELT PATH.....	11	MAINTENANCE AND LUBRICATION.....	25
-Illustrations for Units With End Drive.....	11	-Maintenance Schedules.....	25
-Illustrations for Units With Center Drive.....	11	-Recommended Lubricants.....	26
START-UP PROCEDURES.....	12	-Report on Miscellaneous Maintenance Performed.....	27
-Drive Chain and Sprocket Alignment.....	12	TROUBLE SHOOTING AND REPLACEMENT PARTS.....	28
-Drive Chain and Sprocket Tension.....	12	-Trouble Shooting / Serial Plate.....	28
-Gear Reducer Vent Plug.....	13	PARTS LISTS FOR 196ZPA.....	29
-Preparing for Initial Start-Up.....	13	-Units With 4" and 8" End Drive.....	29-30
BELT TRACKING.....	14	-Units With 4" and 8" Center Drive.....	31-32
-General Information.....	14	WARRANTY.....	35

WARNING LABELS



ABOVE: Label attached to all protective guards (drives, roller guards, etc.)



ABOVE: Label placed near all pulleys (center drives, end drives, tail pulleys)

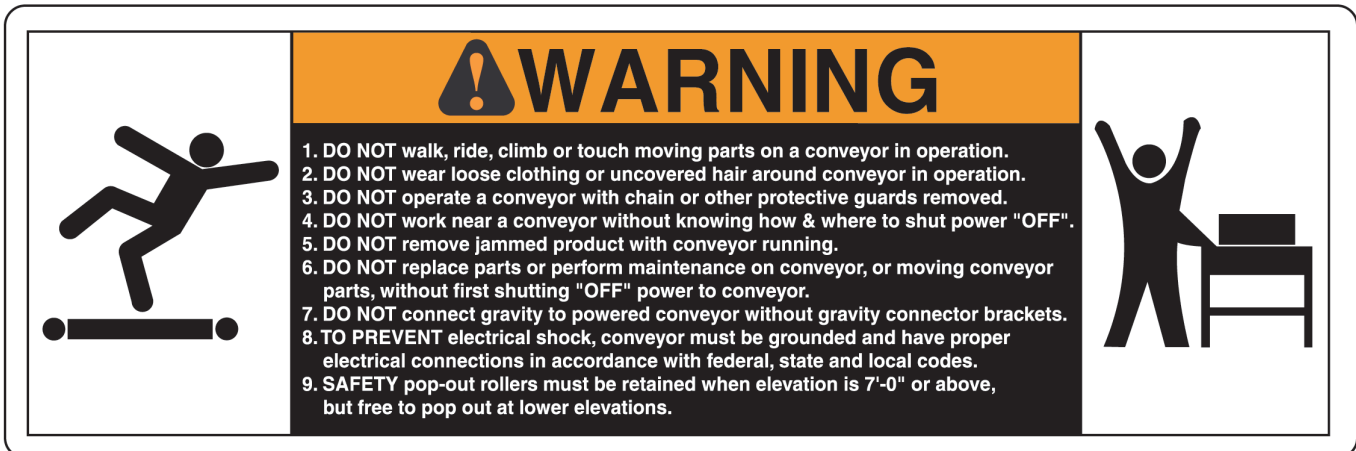

ABOVE: Label placed near all drive assemblies and at 30' intervals

CAUTIONS, WARNINGS AND HAZARDS

INTRODUCTION

This manual was prepared as a “how-to-guide” for installers, end-users and maintenance personnel. It is also intended to educate both owner (purchaser) and all individuals working around the unit, of potential hazards.

With proper installation and maintenance, conveyors are essential for achieving a variety of functions essential in today’s industrial marketplace. By following a simple, periodic maintenance schedule, the life of a typical conveyor (or, most any type of machinery-including our automobiles!) will increase when com-

pared to a similar unit in an application receiving little or no maintenance. You may find that a conveyor can become your best workplace friend by following simple safety guidelines. Failure to follow even the most basic safety suggestions can result in serious personal injury.

Conveyors contain many moving parts-pulleys, belting, chains, sprockets, shafts, rollers, etc. Therefore, it is imperative to become familiar with basic unit operation and know all points of potential hazards.

Remember, when working around or near conveyors (and any industrial machinery)

it is your responsibility to become familiar with the unit, to know potential hazards (many are noted with caution labels) and to operate unit in strict accordance with the safety guidelines in this manual.

Keep this manual in a safe place for future reference. It should be placed where appropriate personnel may maintain proper maintenance and records.

This manual must be read by all new users before operating or working near this unit.

WARNING

**DO NOT OPERATE BEFORE READING THIS MANUAL!
KEEP IN SAFE PLACE--DO NOT DISCARD!**

CAUTIONS, WARNINGS AND HAZARDS

WARNING

 ALWAYS anchor permanent supports to floor (or mounting surface). Use 3/8" x 2-1/2" (or longer) wedge anchors for permanent installation in concrete flooring.

 It is the responsibility of the customer and installation personnel to supply and install net or mesh guarding on overhead mounted conveyors to prevent product and/or debris from falling to floor in areas where required.

 If belt conveyor pulleys are adjusted during installation or maintenance, nip point guard (at drive end on end drive unit) must be readjusted. Nip point guard (take-up end) is automatically adjusted when take-up pulley is adjusted. Nip point guards at both ends of conveyor (center drive) must be readjusted. Center drive guards MUST be replaced after installation or maintenance.

 Before unit is ready for operation, snub roller guard (cover) must be adjusted to ensure safe unit operation.

 Belt lacing must be kept in good condition for safe work environment.

 To check drive sprocket alignment, shut “OFF” and lock out power source before attempting any adjustments.

 To check drive sprocket tension, shut “OFF” and lock out power source before any adjustments are attempted.

 Electrical controls must be designed by a qualified electrical engineer to ensure that appropriate safety features (emergency stops, pull cords, switches, etc.) are installed on unit for safe operation. Before conveyor start-up, all operators and other personnel coming in contact with unit must be properly trained and must have read accompanying Tech Handbook.

 Upon start-up, if belt tracks to one side, turn unit “OFF”, lock out power source and confirm that conveyor is square and that all prime tracking components are square with bed. Belt tracking adjustments should be performed by trained personnel ONLY. Read section on “Belt Tracking” completely before attempting belt tracking adjustments.

 Only trained personnel shall perform maintenance functions. Before maintenance operations are performed, shut conveyor “OFF” and lock out power source to prevent unauthorized start-up. When maintenance is completed, only authorized personnel shall be permitted to start conveyor following maintenance or other emergency shut-off.

SAFETY INFORMATION

IMPORTANT SAFETY GUIDELINES

! WARNING

WARNING: All personnel coming in contact with this conveyor should be aware of the following safety guidelines **BEFORE USING OR WORKING AROUND CONVEYOR**. **NOTE:** ALWAYS notify Roach Manufacturing® whenever any conveyor is used in an application or condition other than was originally intended. Failure to notify Roach® may allow conveyor to be operated in a hazardous operating condition. Injuries resulting from negligence or violation of safety instructions hereby removes responsibility of product liability claims from Roach®.

! Do not operate conveyor with protective guards removed. This includes chain guards, belt guards, snub roller guards, center drive guards and any other safety guard.

! Do not walk, ride, climb, or touch moving parts on a conveyor in operation.

! Do not wear loose clothing or uncovered hair around conveyor.

! Do not work near conveyor without knowing how & where to shut power "OFF" and lock out power source.

! Do not remove jammed product with conveyor running.

! Do not replace parts or perform maintenance on conveyor, or moving conveyor parts, without first shutting "OFF" power to conveyor and locking out power source.

! Do not connect gravity to powered conveyor without safety gravity connector brackets.

! To prevent electrical shock, conveyor must be grounded, and have proper electrical connections in accordance with federal, state, and local codes.

! Safety pop out rollers in conveyors installed above 7'-0" elevation must be retained by guard rail, clips, etc. Safety pop out rollers must be allowed to pop out

when conveyors are installed at or below 7'-0" elevation.

! It is the responsibility of conveyor end-user to comply with all safety standards including OSHA and other federal, state, and local codes or regulations. Install protective guarding and other related safety precautionary equipment to eliminate hazardous operating conditions which may exist when two or more vendors supply machinery for related use.

! Any violation of above safety instructions hereby removes all product liability claims from Roach Manufacturing Corporation®.

UNDERSTANDING POP OUT ROLLERS

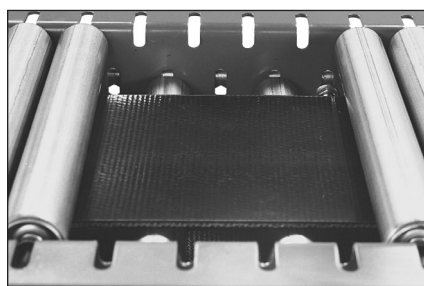

SLOTTED FRAME ALLOWS ROLLERS TO EASILY POP OUT (rollers removed for clarity)



WHEN GUARD RAIL IS ADDED, DO NOT COVER POP OUT SLOTS IN CONVEYOR FRAME*

In most instances, live roller conveyor frames are equipped with slots in the frame for tread rollers. Why is this necessary? When installed below 7'-0" elevation, tread rollers must be designed to pop out of the frame to prevent injury to operator or individuals coming in contact with tread rollers. However, when installed at 7'-0" and greater elevation,

tread rollers must NOT be allowed to pop out. Individuals stationed below the conveyor could be injured by rollers that inadvertently become free from conveyor frame. Therefore, a belt driven live roller originally supplied with slotted frame and pop out rollers, must be modified if it is moved to 7'-0" or higher elevation. A special hold-down angle must be installed

WARNING: Belt driven live roller conveyors must have safety pop out tread rollers when installed below 7'-0" elevation. Conversely, when installed at 7'-0" or greater elevation, tread rollers must NOT be allowed to pop out of frame. Shut conveyor OFF and lock out power source until above safety considerations are completely adhered to.

*NOTE: Guard rail may be used to hold rollers in frame when installed at 7'-0" or higher elevations.

to eliminate pop out rollers. Also, when a live roller conveyor that does not feature pop out rollers, is used in an application below 7'-0" elevation, conveyor MUST be modified to include safety pop out rollers.

Contact Roach national sales at 870-483-7631 with conveyor serial number for additional information.

RECEIVING AND INSPECTION SHORTAGES, DAMAGES AND RETURN AUTHORIZATIONS

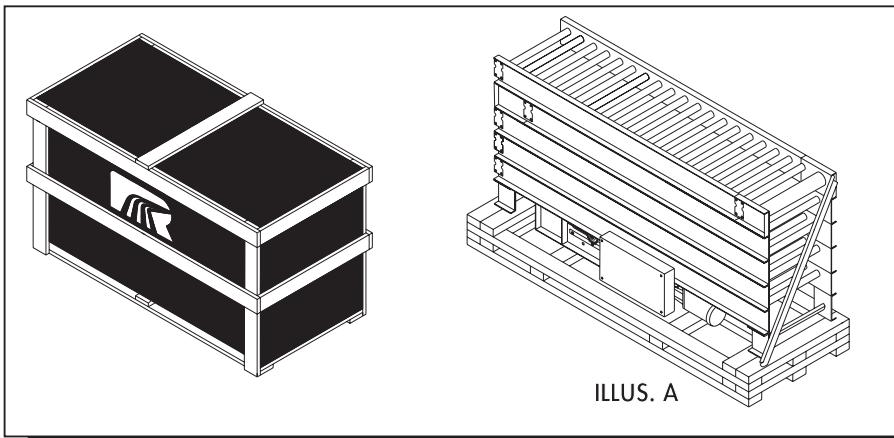

NOTE: Do not return goods to factory without prior, written return authorization. Unauthorized returns are subject to refusal at factory.

Before uncrating, check the quantity of items received against bill of lading to confirm that all material has been received. Examine the condition of the equipment to determine if any damage has occurred.

Also, it is possible that some items may become separated from the original shipment. Therefore, when receiving goods,

it is imperative that the bill of lading (or, accompanying freight documentation) be checked to ensure receipt of ALL units ordered including ALL accessories.

Damage and/or shortage in shipment should be reported immediately to both vendor and carrier. Obtain a signed damage report from carrier agent and send copy to vendor. Do not repair any

damage before obtaining this report.

For damaged shipments, consult factory to determine if entire shipment must be returned to factory for repair or if an immediate order should enter production to produce a new, replacement shipment.

In illustration A above, model 196ZPA is shown palletized for shipment.

UNCRATING AND STORAGE

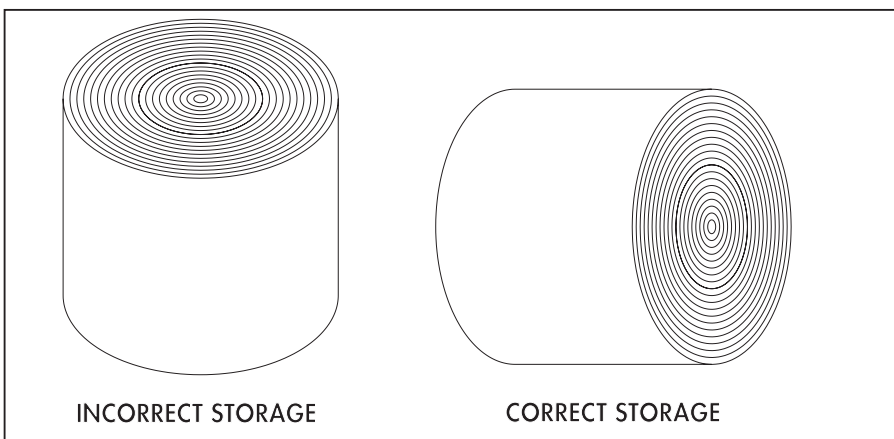

NOTE: Never store belt placed directly on floor. Elevate belting to prevent contact with floor moisture.

After receipt and initial inspection is completed, carefully remove crating and look for essential components and specific accessories that may have been boxed and attached (or 'banded') to crating material. Pop out tread rollers, guard rails and hardware are often packaged and shipped in this manner. Save all hardware for subsequent use by installa-

tion personnel.

The drive section will be shipped mounted to its actual operating bed section (see illustration at top of page). Intermediate bed sections are shipped mounted on top of drive bed section with formed steel stiffener (spacer) brackets.

Belting must be housed in dry quarters.

Do not store belt on edge (see illustration above). Also, never store belt placed directly on floor. Elevate belting to prevent contact with floor moisture.

Some items (electric motors, gearbox, etc.) may be shipped direct from their manufacturer to final destination. Thus, the conveyor may consist of two or more separate shipments.

GENERAL INSTALLATION INFORMATION

COUPLINGS / ATTACHING BED SECTIONS

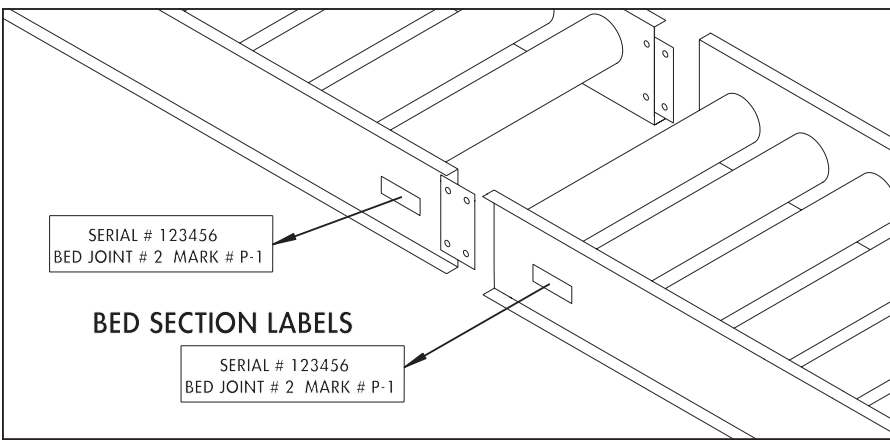

NOTE: It is critical for bed sections to be field assembled in proper sequence following bed section labels.

When preparing to install conveyor, first locate all component sections in the actual installation area. After uncrating, place unit bed sections conveying side up. Each bed section is marked to indicate proper sequence for mating (see illustration above for typical bed section labels).

It is critical for bed sections to be field

assembled in proper sequence following bed section labels. Refer to bed section drawing for location of supports and assemble as shown.

Conveyors are set up at the factory, bed section labels are applied, unit is test run and receives rigorous quality assurance inspection. At this time unit becomes field-ready. Therefore, it is critical that

field installation personnel re-assemble unit by mating beds in accordance with bed section labels (and bed section drawing).

Create a reference base line on floor by marking a chalk line along the centerline of conveyor. Follow base line when installing unit.

UNIT SQUARENESS

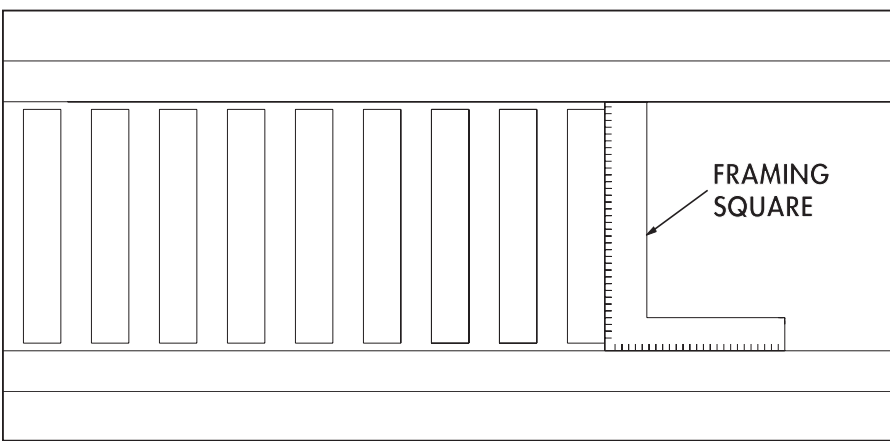

NOTE: One of the most critical elements of proper installation is unit squareness. Check pulleys, snub and return rollers and square each with unit bed.

Use mechanical hoist (fork truck or other available means) to raise bed sections to approximate installed elevation. Mate intermediate sections with splice plates to join bed sections (see illustration at top of page).

One of the most critical elements of proper installation is unit squareness. Check drive pulley, tail pulley, snub roller (if

used in drive assembly) and return roller assemblies to ensure these components are square with unit bed. A framing square can be utilized to confirm that conveyor frame is square. Also, a diagonal measurement across the conveyor frame may be used to determine if the frame is out of square. If measurement is not equal, the frame is not square. Rollers

will be skewed and product will run to one side of the conveyor or perhaps, off of the conveyor in some cases. The importance of unit squareness is perhaps the single most critical stage of installation with belt driven live roller conveyors. If unit is out of square, proceed to next section for adjustments required to square frame and components.

GENERAL INSTALLATION INFORMATION

SQUARING BED SECTIONS

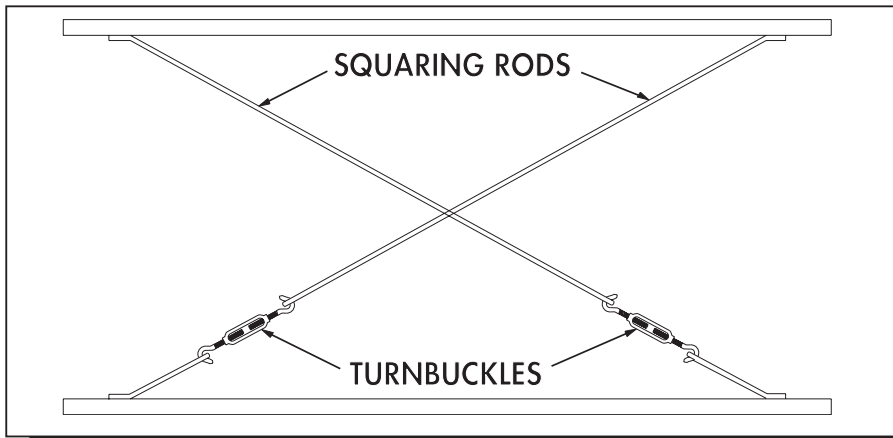

NOTE: Squaring rods are supplied on the underneath side of bed sections and feature a turnbuckle assembly which is used to square accompanying bed sections. Adjust turnbuckle until frame is squared.

When conveyor section is determined to be out of square, adjustments must be made before proceeding to next section.

In illustration above, "x-bracing" or "squaring rods", are used to square a frame that has become "racked" or is otherwise out of square. It is common for bed sections to become racked during transit, thus requiring adjustment during

field assembly. Squaring rods are supplied on the underneath side of bed sections and feature a turnbuckle assembly which is used to square accompanying bed sections. Adjust the turnbuckle until the frame is squared. Confirm by again taking a diagonal measurement. The frame is then square when diagonal measurements from opposite sides are equal in measurement.

Next, tighten bolts in splice plates when frame is square. Finally, conveyor must be installed at level elevation across the width to prevent erratic belt tracking or to prevent package from travelling to one side of conveyor (which is especially possible on long conveyor lines when unit is not installed level across the width).

IDENTIFYING/INSTALLING PERMANENT FLOOR SUPPORTS

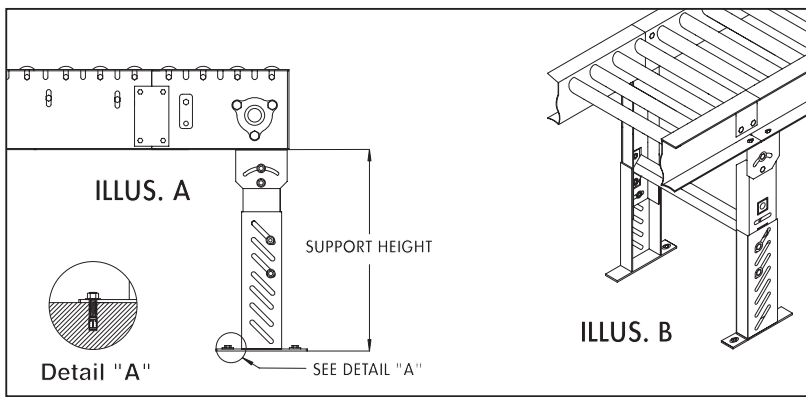

CAUTION: Always anchor permanent supports to floor (or mounting surface). Use 3/8" x 2-1/2" (or longer) wedge anchors for permanent installation in concrete flooring.

*MINIMUM SUPPORT HEIGHT							
MEDIUM DUTY				HEAVY DUTY			
SM-1	7-1/4"	SM-7	36-1/4"	SH-1	6-1/4"	SH-7	25-3/4"
SM-2	10-1/4"	SM-8	46-1/4"	SH-2	7-3/4"	SH-8	31-3/4"
SM-3	13-1/4"	SM-9	58-1/4"	SH-3	10-3/4"	SH-9	43-3/4"
SM-4	16-1/4"	SM-10	70-1/4"	SH-4	13-3/4"	SH-10	55-3/4"
SM-5	20-1/4"	SM-11	80-1/4"	SH-5	16-3/4"	SH-11	67-3/4"
SM-6	24-1/4"	SM-12	92-1/4"	SH-6	19-3/4"	SH-12	79-3/4"

Permanent supports may be installed on conveyors at various locations. However, it is most common to use single tier permanent floor supports at each end of a powered section (see illustration A above) and where intermediate bed sections are adjoined (see illustration B above). Notice intermediate supports have two lag bolts in a diagonal pattern while end (terminal) supports have four lag bolts,

one in each of the four foot plate mounting holes.

When two (or more) powered conveyors are placed end-to-end, a single tier permanent support may be used at the end junction commonly supporting both units. Check load rating of support before using this method of installation.

Adjust elevation to top of conveyor by loosening bolts in support uprights, rais-

ing or lowering conveyor and fully tightening bolts at desired elevation. Tighten all bolts in supports before unit operation. Complete support installation by lagging support attachment plates to floor. Confirm that unit is level across width of conveyor before completing final support height adj.

*Supports are normally shipped at minimum support height. See chart above.

KNEE BRACES, CASTERS AND CEILING HANGERS

INSTALLING KNEE BRACES AND CASTERS

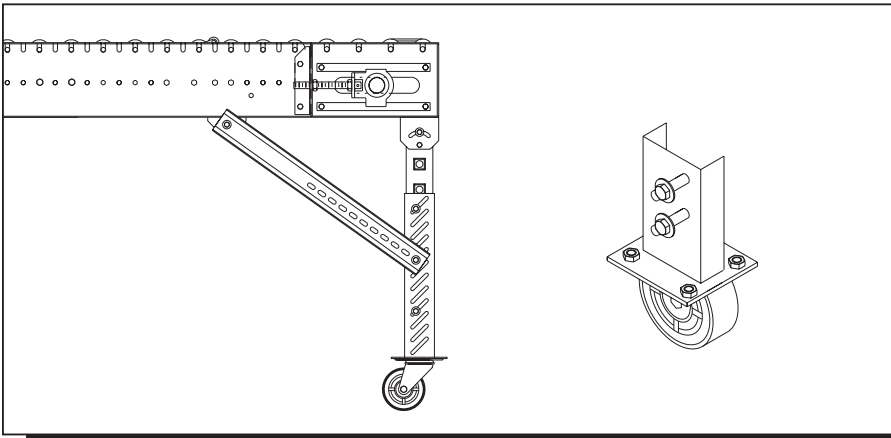

NOTE: Install knee brace (when supplied) after final permanent support installation and elevation adjustment.

Knee braces add strength to permanent supports and stability to units in portable applications. Install knee brace (when supplied) after final permanent support installation and elevation adjustment. Its pivot bracket is bolted to underneath side of lower conveyor flange and slotted end is attached to outer side of support.

Castors (when supplied) are generally installed at the factory. However, when receiving casters direct from their supplier, final attachment to support is necessary. A special slotted pre-punched castor attachment plate is supplied on supports designed for casters.

A standard support is not designed for attachment to casters. Field modification or replacement of outside support assemblies is required.

INSTALLATION OF CEILING HANGERS

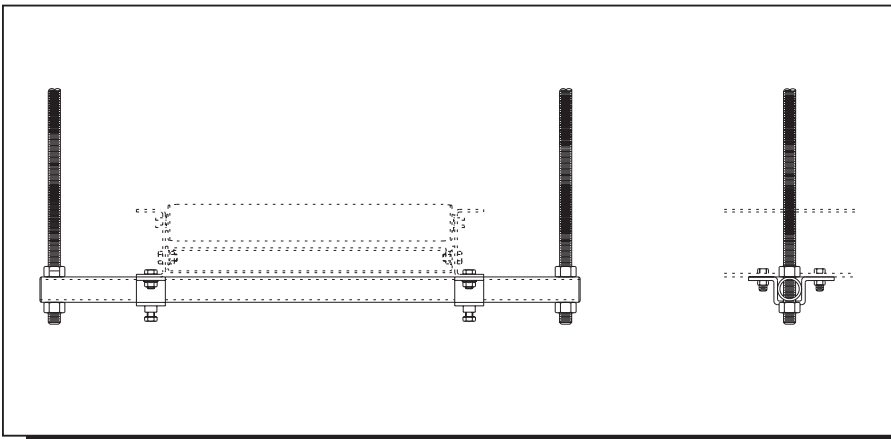

WARNING: It is the responsibility of the customer and installation personnel to supply and install net or mesh guarding on conveyors mounted overhead to prevent product and/or debris from falling to floor in areas where required.

Ceiling hangers are frequently used in high-elevation applications for suspension from ceiling. The 5/8" diameter (#11 UNC) all threaded rod is supplied to allow infinite vertical adjustment along the length of the suspension rod (see illustration above).

Attach and firmly tighten U-shaped retainer ("hat") bracket to underneath side of

lower conveyor flange with hardware provided to hold cross pipe (1" inside diameter) against underneath side of conveyor.

Do not tighten cross pipe locking bolts (these attach in the bottom of the U-shaped retainer bracket) until threaded suspension rods have been firmly secured to ceiling structure.

To adjust conveyor elevation, tighten or

loosen lower nut and jam nut on threaded suspension rods to desired elevation. A lock washer must be used on suspension rods to maintain unit at desired elevation.

When unit is at operating elevation and unit has been levelled across bed width, tighten locking bolts in U-shaped bracket to secure position of cross pipe.

UNDERTRUSSING AND POLYTIER SUPPORTS

INSTALLATION OF UNDERTRUSSING

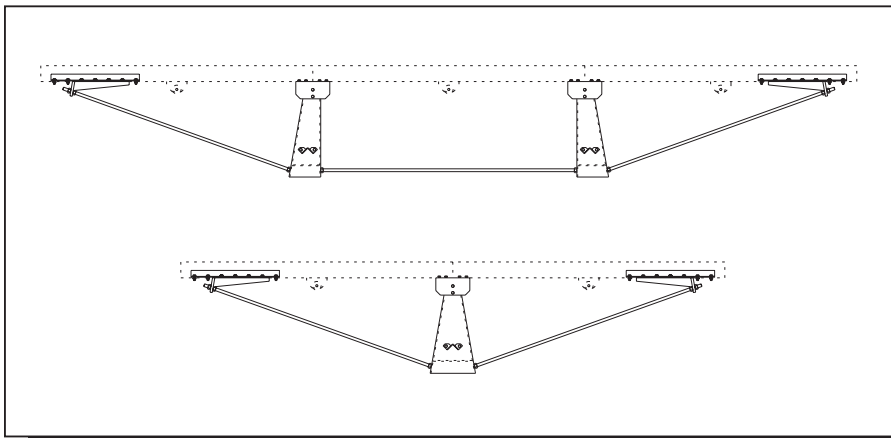

WARNING: It is the responsibility of the customer and installation personnel to supply and install net or mesh guarding on conveyors mounted overhead to prevent product and/or debris from falling to floor in areas where required.

When installing some conveyors, using a permanent support or ceiling hanger is simply not practical. In this situation, three bed sections (maximum) may be joined together utilizing truss assembly, mounted underneath conveyor (see illustration above).

rods (5/8" diameter-11UNC threaded rod). The diagonal connector rod is used not only to support the intermediate bed section joint but it is instrumental for setting and maintaining proper tension across intermediate spanned beds.

tion for final installation.

Adjoin beds on floor using both connector rod support assemblies and connector

Use mechanical hoist (fork truck or other means) to raise pre-assembled bed sections (with undertrussing) to desired elevation

Use diagonal connector rods to level the undertrussed beds both along and across the conveyor. Remember that the tension must provide adequate for both dead load (conveyor weight) and product load during unit operation.

INSTALLATION OF POLYTIER SUPPORTS

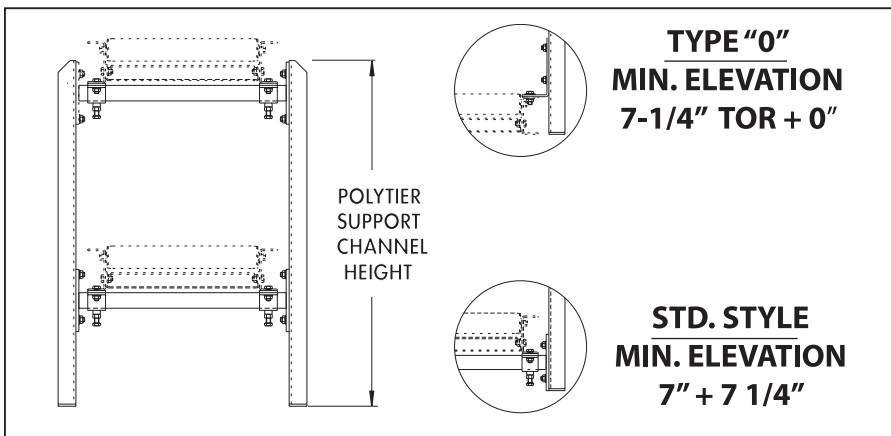

NOTE: To install, raise conveyor to desired elevation, place cross pipe underneath lower conveyor flange, attach cross pipe to upright legs and use U-shaped retainer ("hat") bracket to connect cross pipe to lower conveyor flange.

POLYTIER SUPPORT CHANNEL HEIGHT					
PSM-1	23"	PSM-6	53"	PSM-11	83"
PSM-2	29"	PSM-7	59"	PSM-12	89"
PSM-3	35"	PSM-8	65"	PSM-13	95"
PSM-4	41"	PSM-9	71"	PSM-14	101"
PSM-5	47"	PSM-10	77"	PSM-15	107"

Polytier supports provide convenient installation method for two or more tiers of conveyor. To install, raise conveyor to desired elevation (approximate). Place 1" inside diameter cross pipe underneath lower conveyor flange. Attach cross pipe to upright legs. Use U-shaped retainer ("hat") bracket to connect cross pipe to lower conveyor flange. Do not tighten fully at this time.

There are two styles of attachment brackets available for use with polytier supports. Minimum elevation style (see TYPE "0", illustration above) offers lowest unit elevation, 0" + frame depth utilizing L-shaped mounting bracket. Standard elevation style offers unit elevation of 3-1/2" + frame depth and includes bracket welded to cross pipe which is bolted to upright legs during installation.

When unit is at operating elevation and unit has been checked across width for level, tighten locking bolts in U-shaped bracket. Add knee braces for unit rigidity.

*NOTE: Overall conveyor height is dictated by type of drive assembly used-i.e. underneath, center drive, sidemount, etc.

INSTALLATION OF BELTING

BELT CONNECTIONS

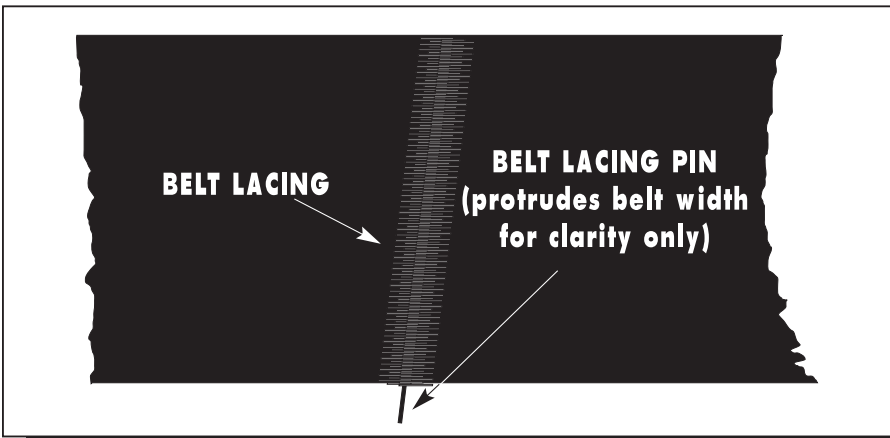

CAUTION: Belt lacing must be kept in good condition for safe work environment.

Conveyor belting is cut to proper length, laced and assembled on conveyor at the factory. It is test run and inspected before it is shipped to its final destination.

Before field installation of belting, the correct side to be placed down must be determined. 6" wide PVC belting is supplied as "COS" (cover one side, friction surface other side). The friction surface

offers decreased friction and less driving force. The friction side appears dull and grainy; the cover side darker and shiny. On model 196ZPA, place cover side of belt up.

If unit is shipped "knocked down," belt must be re-threaded on unit during installation (see opposite page). Join ends of belt as shown above with lacing pin.

Loosen threaded take-up rods (if necessary) at take-up pulley equal amount on both sides and re-adjust when belt is installed keeping pulley square with conveyor bed. A belt puller can also be used to join belting.

MAINTAINING PROPER BELT TENSION

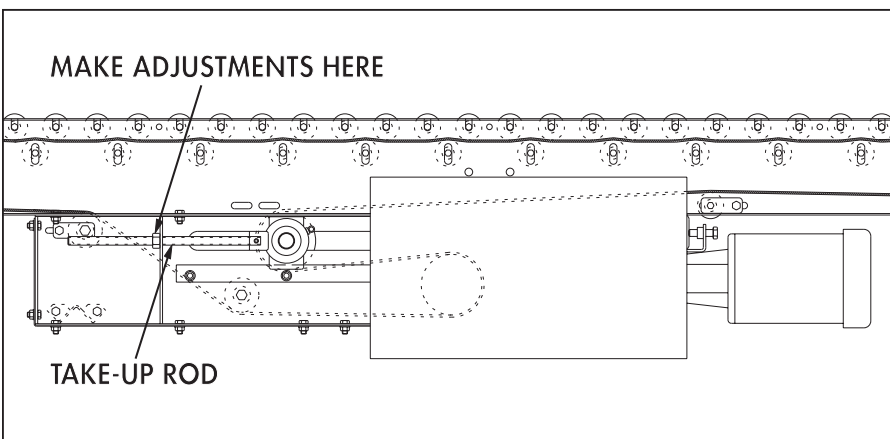

CAUTION: Belt lacing must be kept in good condition for safe work environment. Also, do not operate unit with improper belt tension. Unit is subject to abnormal wear and maintenance when operated with belt incorrectly adjusted.

Maintaining proper belt tension is vital to unit operation. Enough tension should be maintained so that drive pulley does not slip under fully loaded conditions.

It is perfectly normal for a belt to stretch (in varying climatic conditions) under rated loading. Therefore, a short belt insert or "belt patch" (or patches) is provided for future removal when belting has stretched

beyond means of conveyor take-up assembly. For yet additional belt take-up, the belt should be cut and re-laced to maintain proper belt tension.

To adjust conveyor take-up, adjust position of take-up rod (see illustration above) as required. Remember to equally adjust both sides to hold take-up pulley square (to maintain unit squareness for belt tracking).

Operating unit with slipping belt will decrease life of both belting and pulley lagging. Also, do not operate unit with too much tension on belt. This will decrease belt life and may harm unit drive and take-up bearings. Over tensioning belt requires additional horsepower from unit drive.

BELT PATH ILLUSTRATION FOR UNITS WITH END DRIVE

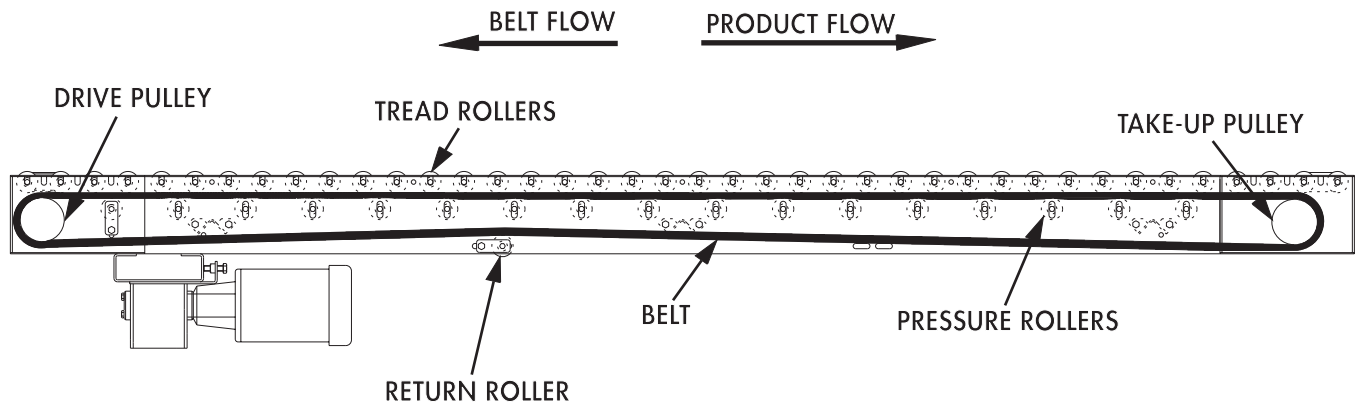

WARNING: Belt driven live roller conveyors must have safety pop out tread rollers when installed below 7'-0" elevation. When installed at 7'-0" or higher elevation, tread rollers must NOT be allowed to pop out of frame.

ILLUSTRATION FOR UNITS WITH CENTER DRIVE

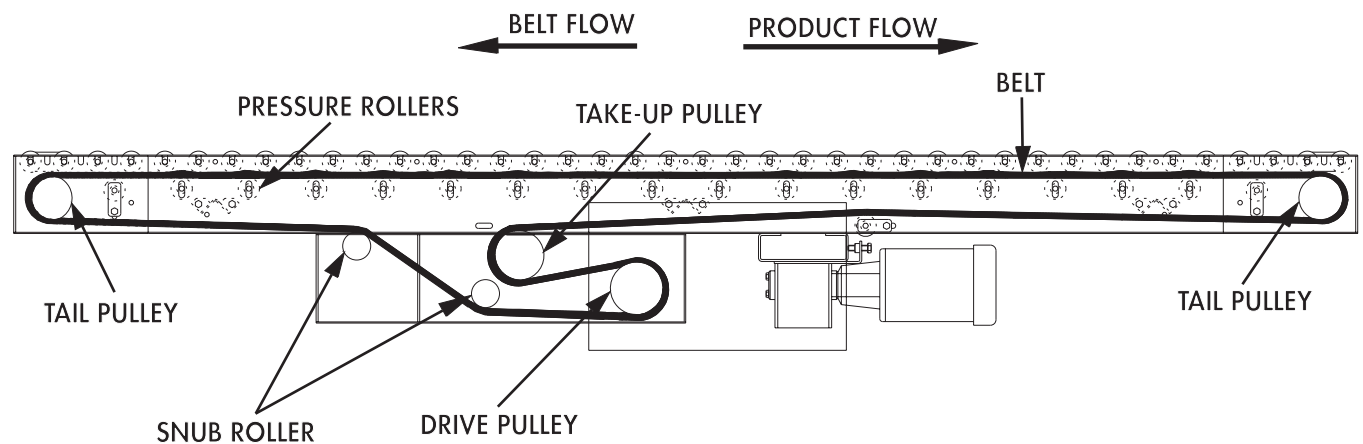

WARNING: Belt driven live roller conveyors must have safety pop out tread rollers when installed below 7'-0" elevation. When installed at 7'-0" or higher elevation, tread rollers must NOT be allowed to pop out of frame.

START-UP PROCEDURES

DRIVE CHAIN AND SPROCKET ALIGNMENT

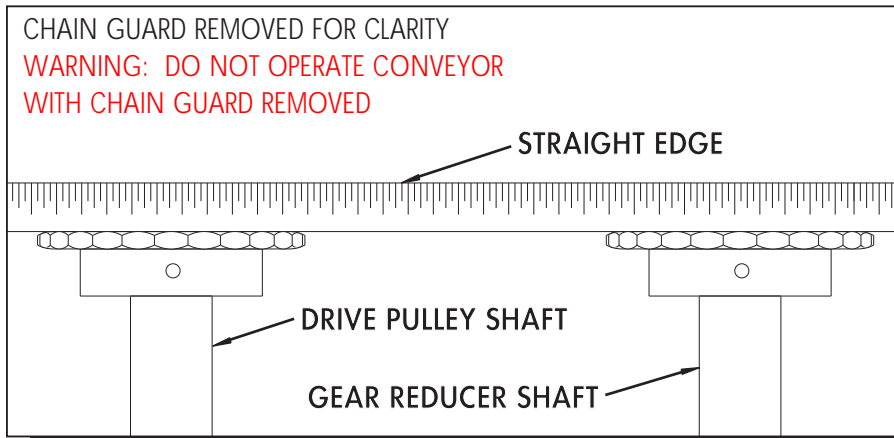

WARNING: To check drive sprocket alignment, it is imperative that conveyor is shut "OFF" and power source is locked out before any adjustments are attempted.

Set up and maintenance of drive sprocket and drive chain alignment is critical. A periodic visual inspection is recommended to confirm alignment of drive components (which includes both drive sprockets and drive chain). Should set screws become loose, drive sprockets are subject to excessive wear and ultimately, to untimely replacement.

To check drive sprocket alignment, it is imperative that conveyor is shut "OFF" and power source is locked out before any adjustments are attempted. Remove chain guard cover and place straight-edge (see illustration above) across face of both drive sprockets. If re-alignment is necessary, loosen set screws and adjust drive sprockets as required. Remember

to securely tighten set screws when alignment is complete.

Before replacing chain guard cover, check drive chain tension as described in following section, "Drive Chain and Sprocket Tension."

DRIVE CHAIN AND SPROCKET TENSION

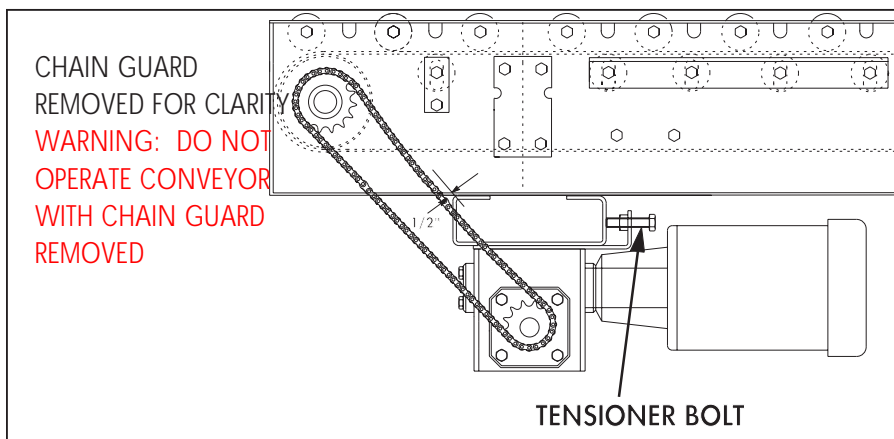

WARNING: To check drive sprocket tension, shut "OFF" and lock out power source before any adjustments are attempted.

Maintaining proper chain tension is especially important. Again, a periodic visual inspection is recommended to ensure chain tension within a pre-determined operating range.

Remember, before any adjustments are attempted, conveyor must be shut "OFF" and power source locked out.

Before replacing chain guard cover,

check to see if drive chain is operating within 1/2" range (see above illustration). If unit is out of tolerance, adjustment is necessary.

To adjust drive chain tension, tensioner bolt located on reducer push plate should be tightened (rotate clockwise) if chain tension is loose. Tighten until proper operating range is achieved. If chain

tension is too tight, loosen tensioner bolt (rotate counterclockwise) as required. When adjustment is complete replace chain guard cover.

WARNING: Do not operate unit until chain guard cover is replaced. Serious operator or other personal injury could result if protective guarding is not replaced.

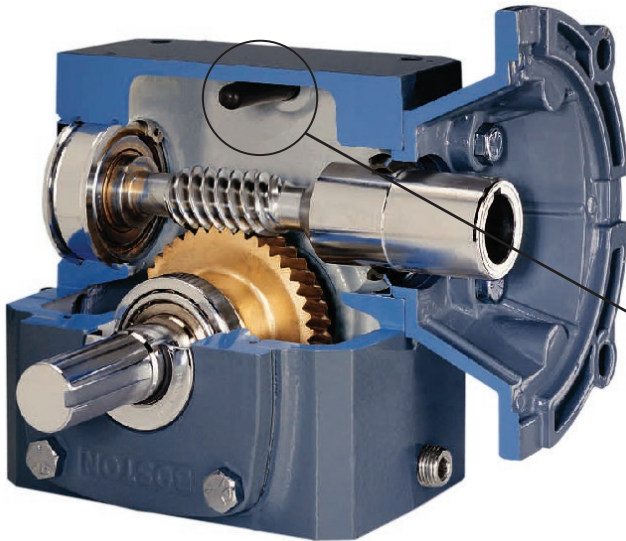

NOTE

The gear reducer is supplied with a "PosiVent[®]". No vent plugs are required.

PosiVent Unique design incorporates a single seam construction. Factory filled with synthetic lubrication for universal mounting. Lubed for life, no oil changes are required.

To expedite the installation and start-up process, all gear reducers are shipped filled with oil. The reducers are sealed and lubed for life and require no oil changes.

PREPARING FOR INITIAL START-UP



⚠ DANGER

WARN ALL PERSONNEL TO KEEP CLEAR OF CONVEYOR DURING UNIT START-UP

Electrical controls must be designed by a qualified electrical engineer to ensure that appropriate safety features (emergency stops, pull cords, switches, etc.) are installed on unit for safe operation. Before conveyor start-up, all operators and other personnel coming in contact with unit must be properly trained and must have read accompanying Tech Handbook.

Before conveyor start-up, all operators and other personnel coming in contact with unit must be properly trained and must have read accompanying Tech Handbook.

Provisions must be in order to instruct all personnel coming in contact with conveyor on the location of emergency stops, pull cords, etc.

A routine maintenance program should be implemented before unit is placed into operation so that fundamental unit components are attended to. This maintenance program should include an inspection to ensure that any dangerous or hazardous operating conditions are noted and IMMEDIATELY corrected, as well as including electrical and mechanical unit inspections and corrections.

Finally, when conveyor is initially started, an immediate visual inspection should include motor, gear reducer, belt tracking (discussed in following section under "Belt Tracking") and related adjustments noted in handbook for unit/component corrections.

BELT TRACKING

GENERAL INFORMATION

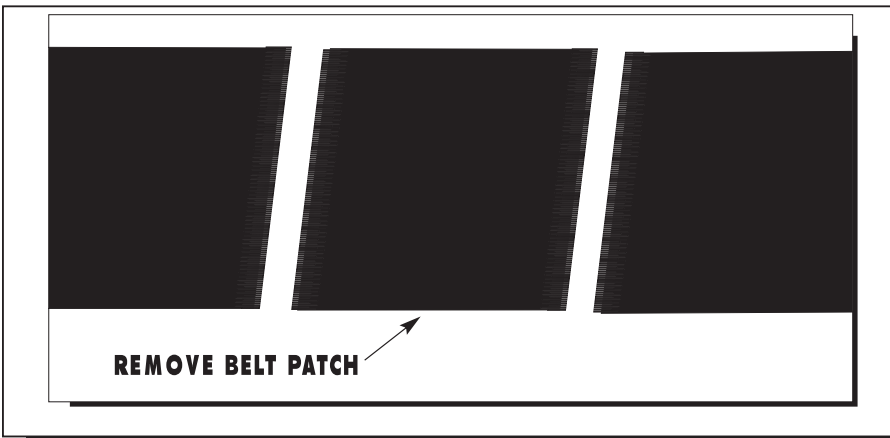

CAUTION: Upon initial operation the belt will stretch. To maintain proper belt tension, adjustment of the take-up pulley or removal of belt patch will be required. ONLY trained personnel should make belt tracking adjustments.

Upon initial use belting will stretch after a few days of operation. Remember that maintaining proper belt tension is a crucial element in belt tracking. Therefore, this stretching of a belt when placed into operation may affect its ability to track. Adjustment of the take-up pulley will likely adequately compensate for initial stretch. However, depending on the overall unit

length, removal of a belt patch may be necessary to correct.

The return direction of the belt must clear supports, ceiling hangers, floor openings, etc. Dragging on such components will contribute to belt tracking problems and is certain to damage belting at extended intervals. Also, do not allow belt to rub against conveyor side frame.

In a reversible application, a belt that runs off to one side in one direction will likely run off to the other side when operated in the opposite direction.

Belt must be tracked in both unloaded and loaded situations. See following step for installation of tread rollers to track belt in loaded situation.

POP OUT ROLLERS & INSTALLATION OF TREAD ROLLERS

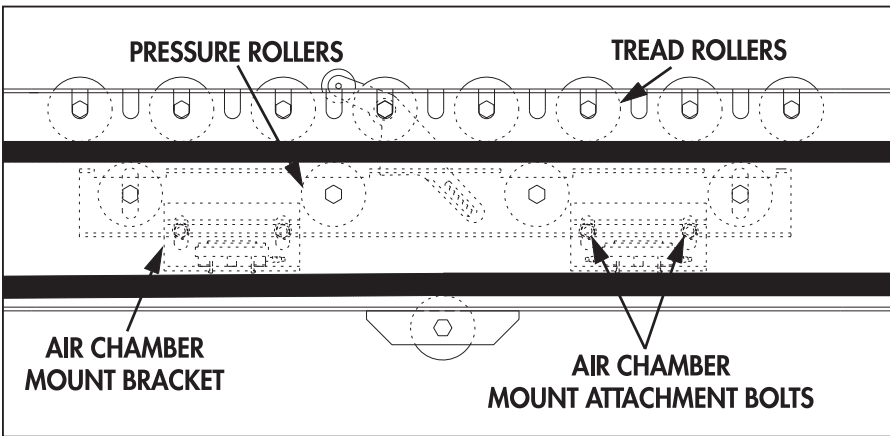

CAUTION: ONLY trained personnel should make belt tracking adjustments. Shut unit "OFF" and lock out power source before attempting adjustments in belt tracking.

WARNING: Belt driven live roller conveyors must have safety pop out tread rollers when installed below 7'-0" elevation. Conversely, when installed at 7'-0" elevation or greater, tread rollers must NOT be allowed to pop out of frame.

Belt driven live roller conveyors (including model 196ZPA) must have safety pop out tread rollers when installed below 7'-0" elevation to allow tread rollers to pop out of frame to prevent injury to operator or individuals coming in contact with tread rollers. When installed at 7'-0" or higher elevation, tread rollers must be installed in a NON pop out design to prevent rollers from popping out and causing injury to

individuals stationed below the conveyor. Therefore, the frame should be punched rather than slotted OR a hold down angle must be used to eliminate pop out rollers in high elevation applications. (See "UNDERSTANDING POP OUT ROLLERS", page 4).

Remove tread rollers from shipping crate and install in conveyor and track belt under loaded conditions. Confirm that

return rollers, beds and all pulleys are squared.

Finally, adjustment of the chamber mount bracket may be required to set proper pressure roller tension. Although preset at factory, chamber mount may require adjustment after transit. Adjust chamber mount as required (see above illustration).

BELT TRACKING

ERRATIC TRACKING AT START-UP

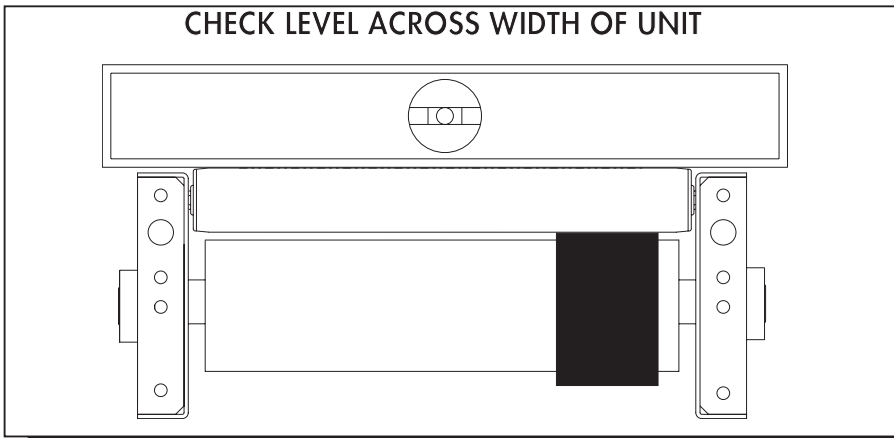

CAUTION: Upon start-up, if belt tracks to one side of unit, turn unit "OFF", lock out power source and confirm that conveyor is square and that all prime tracking components are square with bed. Belt tracking adjustments should be performed by trained personnel ONLY.

Improper tracking of conveyor belting should be considered a "systems" problem rather than solely a deficiency in the belt. To explain, a belt is tracked with adjustments made to the conveyor rather than just the belting.

Upon start-up, if belt tracks to one side of unit, turn unit "OFF", lock out power source and confirm that conveyor is

square. All prime tracking components must be square with bed including drive pulley, tail pulley, snub roller and return rollers. Both sides of take-up should be adjusted exactly the same amount. The conveyor should be level across the width of the unit. Confirm that the belt has been properly threaded (see "Belt Path" section) and that belt lacing is square

with the belt edges. Make adjustments as necessary; however, all adjustments should be made in small increments.

Start conveyor again and operate for at least ten minutes once initial phase of adjustments are complete. If belt continues to track erratically, turn unit "OFF" and proceed to following section.

ADVANCED TRACKING ADJUSTMENTS

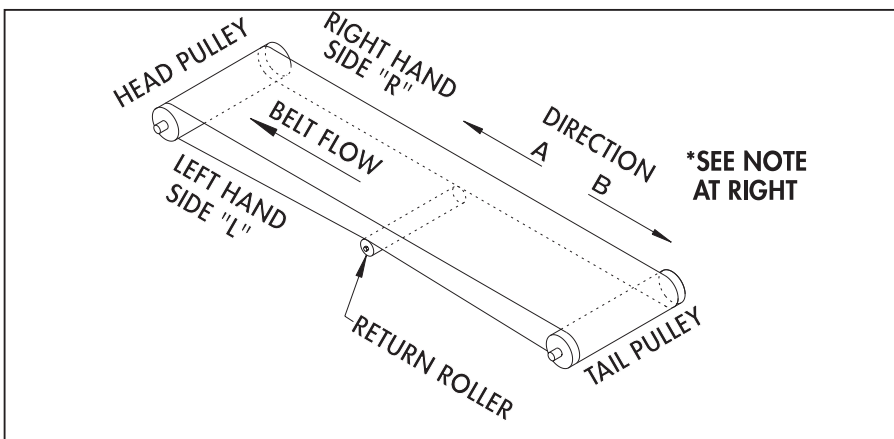

CAUTION: Belt tracking adjustments should be performed by trained personnel ONLY. Read section on "Belt Tracking" completely before attempting belt tracking adjustments.

*NOTE: When making adjustments in direction "A" or direction "B", component must pivot from side "L" with actual component movement on side "R".

When adjustments noted in previous sections have been completed and belt continues to track erratically, a final series of tracking adjustments are necessary.

The following adjustments will be made referring to the direction of belt flow and not the product flow of the conveyor.

If belt tracks toward side "R" (see illustration above), skew return rollers in direc-

tion "B" to shift belting toward side "L". If belt tracks toward side "L", skew return rollers in direction "A" to shift belting toward side "R".

Skewing head pulley (pulley at unit discharge) in direction "A" moves belt toward side "L". Skewing head pulley in direction "B" moves belt toward side "R".

As a rule of thumb, do not use drive and

take-up pulley for belt tracking since this will overly increase belt tension. When adjusting take-up pulley, adjust both sides an equal amount.

As a last resort, shift the tail pulley in direction "B" to move belting toward side "L"; shift head pulley in direction "A" to move belting toward side "L".

TECHNICAL - STANDARD 196ZPA OPERATION

STANDARD 196ZPA ACCUMULATION OPERATION

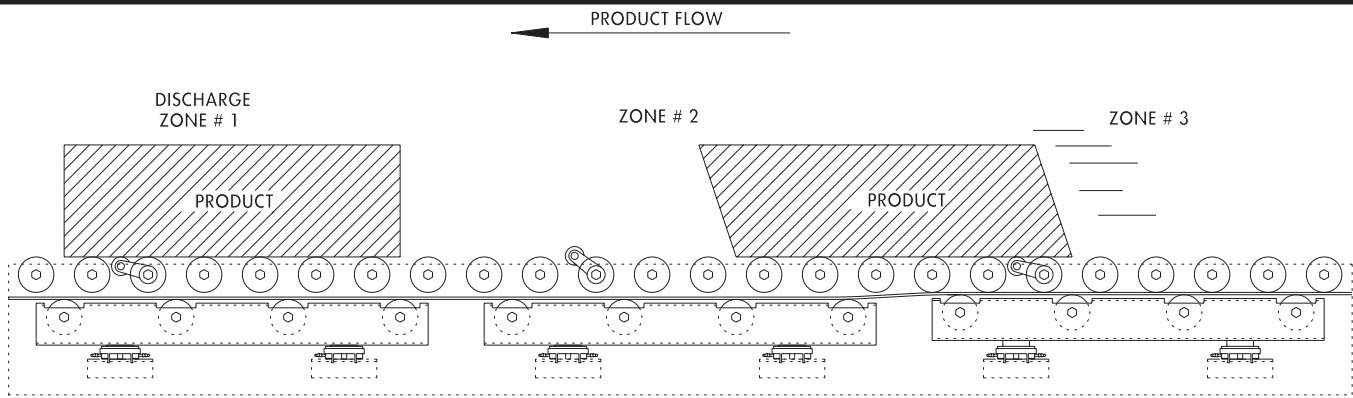

Model 196ZPA offers zero pressure accumulation, or in simplified terms, package accumulation without buildup of damaging line pressure. By utilizing 2'-0" long zones (or other varying length zones), packages of varying weights and sizes are accumulated, maximizing overall unit length.

Here's how this conveyor works. The first package entering the conveyor travels

to the discharge zone. If the package does not travel onto the discharge zone far enough to depress the sensor roller mechanism located in discharge zone #1, the second package will contact the first package and push this package far enough to depress the sensor roller mechanism. When this sensor roller is depressed, zone #2 (see above diagram) becomes non-powered to receive and

accumulate the next package. This process is continually repeated during accumulation. The last zone with a raised sensor roller is always non-powered during standard 196ZPA accumulation operation. Therefore, a trailing zone is powered to feed package onto a non-powered zone until the package depresses a sensor roller.

PNEUMATIC PLUMBING FOR STANDARD 196ZPA ACCUMULATION

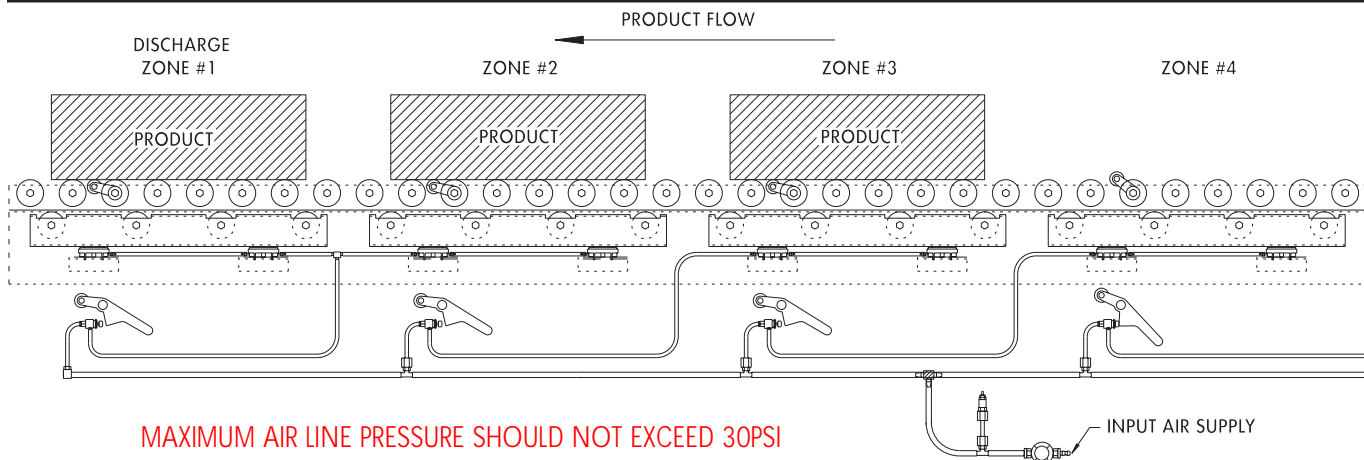

During unit setup and testing at factory, model 196ZPA is fully operational. All zones and accompanying valves are thoroughly tested prior to rigorous quality assurance inspection.

The diagram above illustrates typical plumbing of primary pneumatic components. Input air supply line delivers air to unit combined with valve to control logic

from zone-to-zone. Air flow is routed to a valve controlled by the pivoting action of individual sensor roller mechanism. When a package enters the discharge zone and depresses the sensor roller, a pneumatic valve is actuated controlling zone #2. This valve prevents flow of air into zone #2 thus allowing air cylinders to deflate and subsequent release of rollers

in zone #2. Now, rollers in zone #2 are non-powered and will remain in this state until unit is in its off-loading mode. Zone #3 will remain powered (until the sensor roller in zone #2 is depressed) and will therefore send a package into zone #2. This process is repeated for the entire unit for all successive zones during standard 196ZPA accumulation operation.

TECHNICAL - STANDARD 196ZPA OPERATION

PNEUMATIC PLUMBING FOR BRAKE ASSEMBLY IN DISCHARGE ZONE

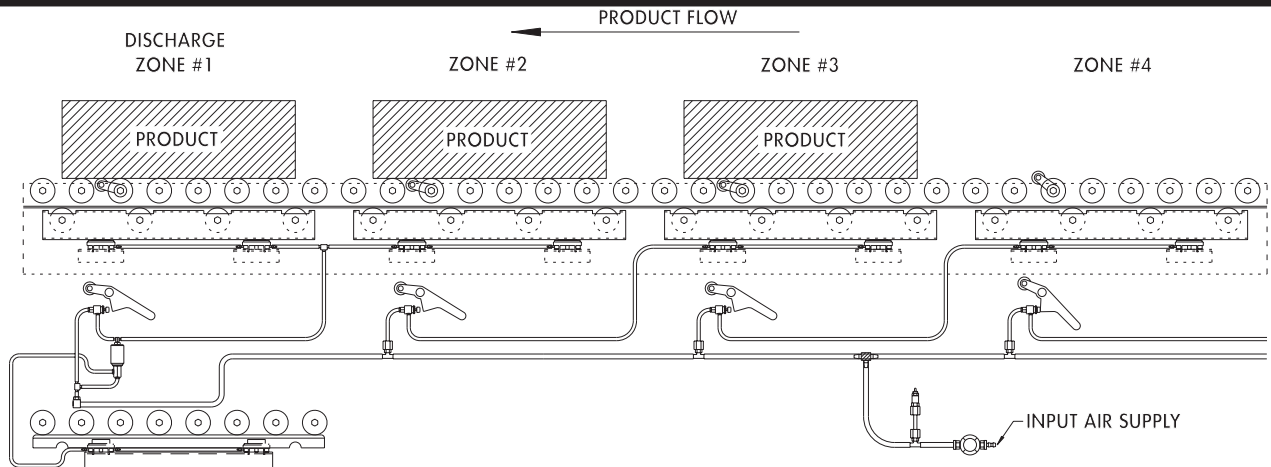

During accumulation, package may coast beyond the intended accumulation zone. Therefore, consideration must be given to options designed to curtail package coast for standard 196ZPA accumulation operation.

In the illustration above, a discharge zone brake assembly is added. On the side

opposite drive belting, a brake assembly is added in the discharge zone. This brake assembly is pneumatically raised and lowered to "brake" the tread rollers when the discharge zone enters its accumulation mode. This simple addition is designed to eliminate package coasting through the discharge zone.

As shown above, a valve is placed in the discharge zone assembly which routes the flow of air into the discharge brake assembly once a package depresses the discharge zone sensor roller, thus activating the brake assembly.

PNEUMATIC PLUMBING FOR SOLENOID IN DISCHARGE ZONE

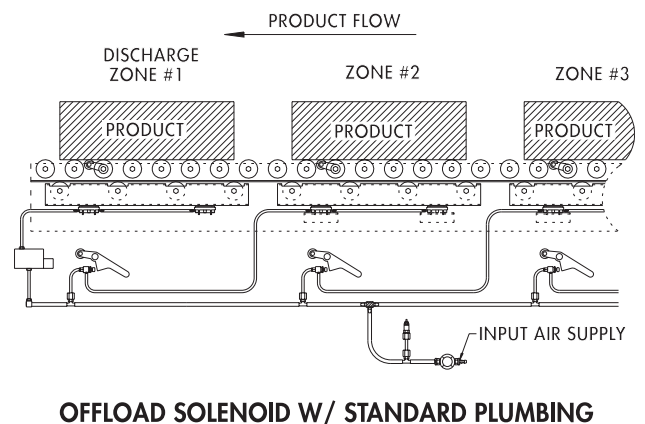
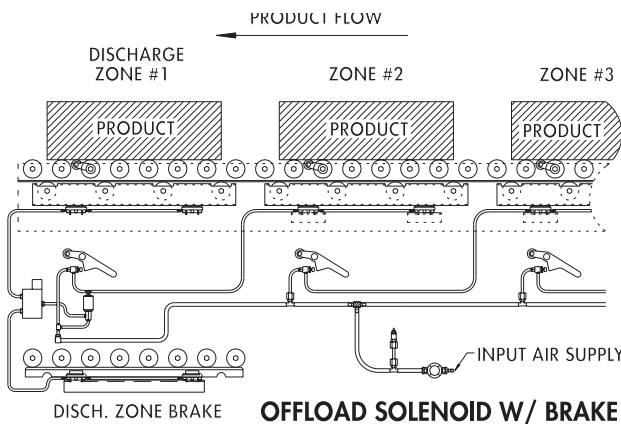

Beyond accumulating packages, consideration must be given as to the manner in which a 196ZPA will be OFF-LOADED. Obviously there are various ways to remove product from conveyor. Most simply, an operator may be stationed near the discharge end of unit and will manually remove packages from conveyor allowing packages to advance onto

and subsequently off of, the discharge zone. However, most common are those applications requiring the conveyor to receive an electrical 115 volt signal from either another conveyor or from machinery for packages to be discharged off the conveyor.

A solenoid valve is used to receive a 115 volt signal which is located as shown in

the illustrations above. At left, a solenoid valve is plumbed to operate in conjunction with a pneumatic brake assembly. At right, a solenoid valve is utilized for off-loading in a model otherwise equipped with standard 196ZPA accumulation operation.

TECHNICAL - OPTIONAL ZONE SINGULATION OPERATION

OPTIONAL ZONE SINGULATION ACCUMULATION

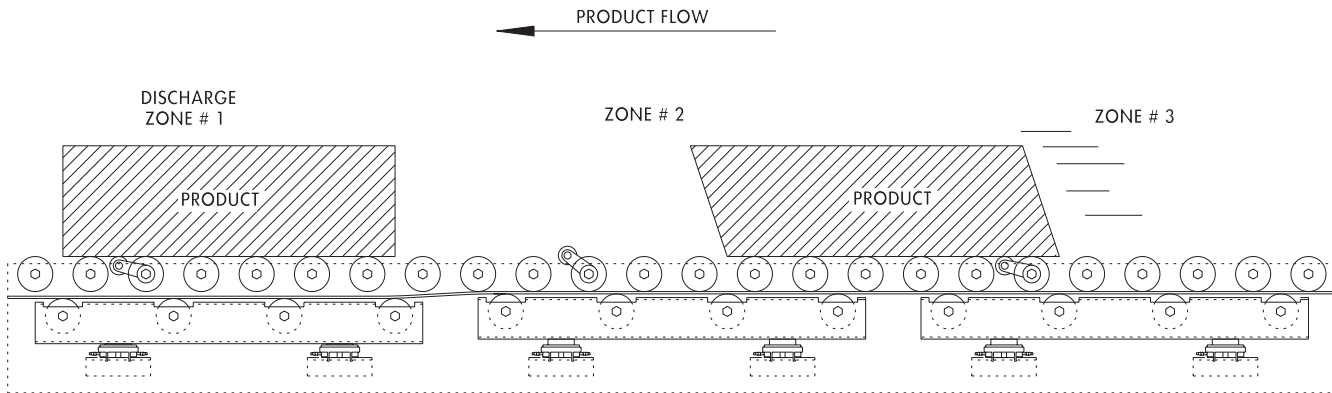

One of the most utilized options on model 196ZPA, is zone singulation accumulation operation. Zone singulation allows product to be efficiently offloaded—or singulated and also, generally limits an individual zone to receiving one package per zone.

Here's how the 196ZPA operates when equipped with optional zone singulation.

The first package entering the conveyor travels to the discharge zone and stops when it depresses the sensor roller mechanism located in the discharge zone. All successive packages repeat this simplified process during zone singulation accumulation. The second package travels until it depresses the sensor roller mechanism in zone #2 (see above diagram) where

it will remain accumulated. Each time a sensor roller is depressed, a signal is relayed to the immediate trailing zone informing that trailing zone to receive and accumulate the next package.

PNEUMATIC PLUMBING FOR ZONE SINGULATION

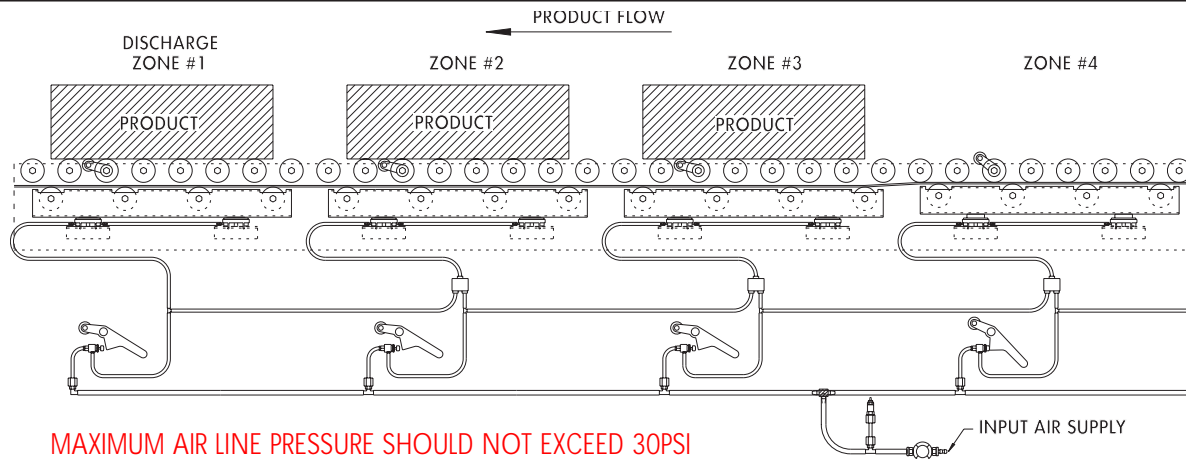

During unit setup and testing at factory, model 196ZPA is fully operational. All zones and accompanying valves are thoroughly tested prior to rigorous quality assurance inspection.

The diagram above illustrates typical plumbing of primary pneumatic components to achieve zone singulation operation. Input air supply line delivers air to unit combined with valve to control logic

from zone-to-zone. Air flow is routed to a valve controlled by the pivoting action of individual sensor roller mechanism. When a package enters the discharge zone and depresses the sensor roller, a pneumatic valve is actuated controlling zone #2. Therefore, the next package will enter zone #2 and will be accumulated in zone #2 when it depresses the sensor roller mechanism located in zone #2.

This process is repeated for all successive zones during optional zone singulation operation on model 196ZPA. Rollers are always powered in the discharge-most non-accumulated zone—the primary OPERATING difference between standard 196ZPA operation and zone singulation operation.

TECHNICAL - OPTIONAL ZONE SINGULATION OPERATION

PNEUMATIC PLUMBING FOR BRAKE ASSEMBLY IN DISCHARGE ZONE

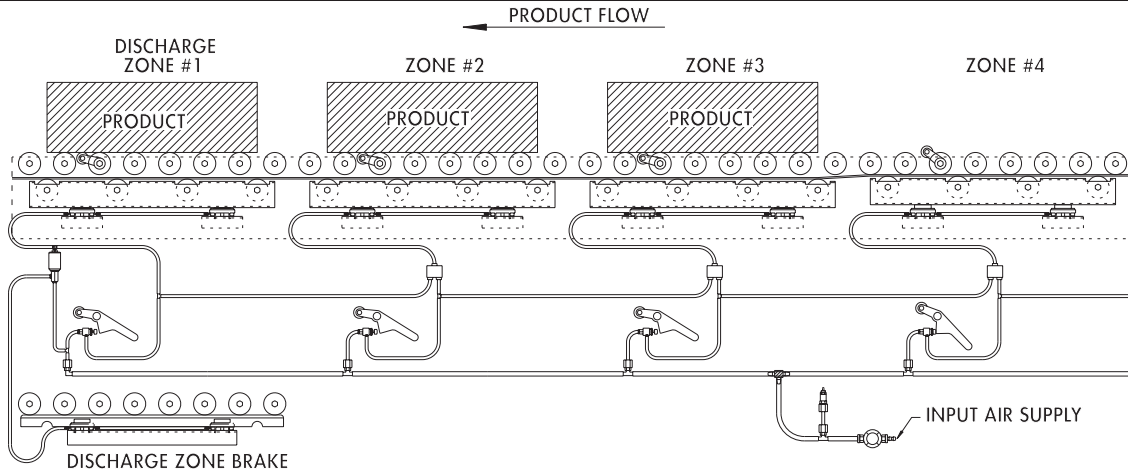

During accumulation and depending on conveyor operating speed, package may coast beyond the intended accumulation zone. Consideration must be given to options designed to curtail package coast for zone singulation accumulation.

In the illustration above, a discharge zone brake assembly is added. On the side

opposite drive belting, a brake assembly is added in the discharge zone. This brake assembly is pneumatically raised and lowered to "brake" the tread rollers when the discharge zone enters its accumulation mode. This simple addition is designed to eliminate package coasting through the discharge zone.

The pneumatic plumbing diagram above illustrates how the discharge brake assembly is pneumatically incorporated to curtail package coast from the discharge end of model 196ZPA during optional zone accumulation operation.

PNEUMATIC PLUMBING FOR SOLENOID IN DISCHARGE ZONE

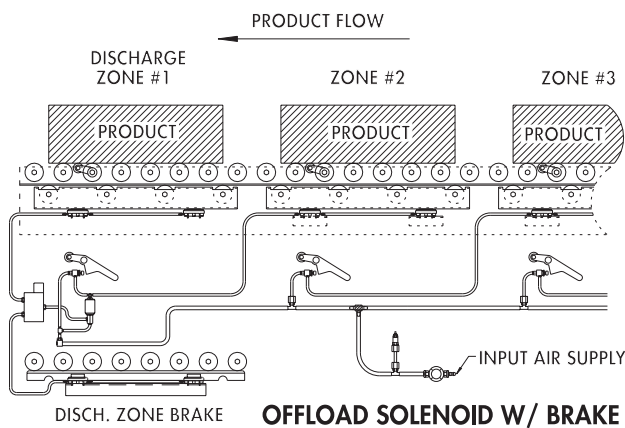

OFFLOAD SOLENOID W/ BRAKE

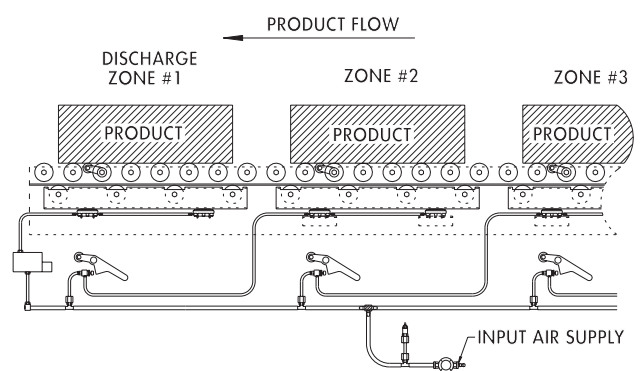

OFFLOAD SOLENOID W/ STANDARD PLUMBING

Beyond accumulating packages, consideration must be given as to the manner in which a 196ZPA will be OFF-LOADED. Obviously there are various ways to remove product from conveyor. Most simply, an operator may be stationed near the discharge end of unit and will manually remove packages from conveyor allowing other packages to move

forward onto and subsequently off of, the discharge zone. However, most common are those applications requiring the conveyor to receive an electrical 115 volt signal from either another conveyor or from machinery for packages to be discharged off the conveyor.

A solenoid valve is used to receive a 115 volt signal which is located as shown in

the illustrations above. At left, a solenoid valve is utilized for off-loading in a model equipped with optional zone singulation accumulation operation. At right, a solenoid valve is plumbed to operate in conjunction with a pneumatic brake assembly with zone singulation accumulation.

TECHNICAL - SMART ZONE®

SMART ZONE® OPERATION

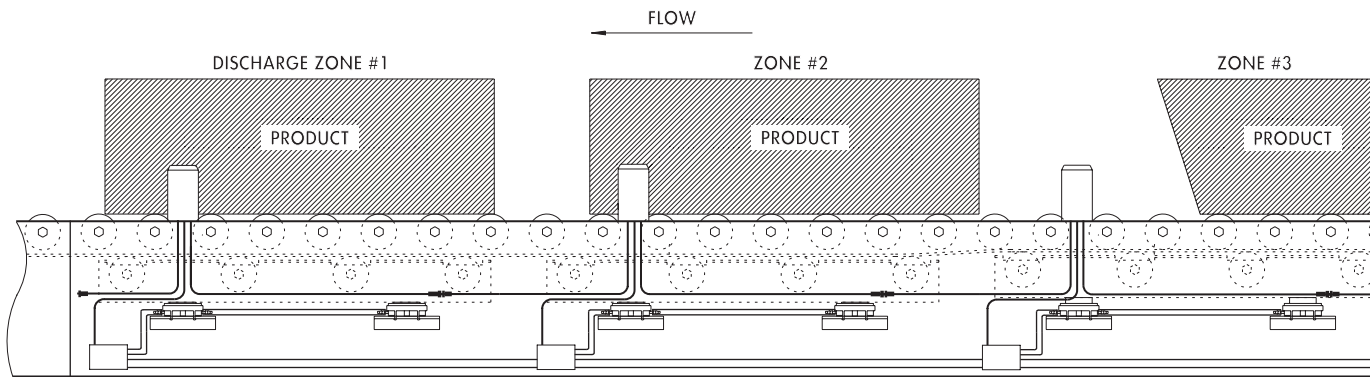

Roach® Smart Zone® model SZ196ZPA is a zero pressure accumulation conveyor utilizing photo sensors rather than mechanical sensor rollers to detect presence of product. Each requires photo sensor, reflector, solenoid valve and two pneumatic cylinders per zone. Also, a 24 volt DC power supply with 115/1 input voltage is required per conveyor, which is capable

of powering up to 50 zones. The power supply delivers a low voltage signal to each "daisy-chained" photo sensor located in each accumulating zone.

Since Smart Zone® does not require physical package or carton weight to depress mechanical sensor, minimal weight objects can be accumulated.

Here's how Smart Zone® accumulates. The first package on the conveyor travels until it blocks the photo sensor in discharge zone #1. The next package accumulates in zone #2 when it blocks the photo sensor in zone #2. The next package accumulates in zone #3 and so forth. This process is repeated for all successive zones on Smart Zone®.

SMART ZONE® DETAILS

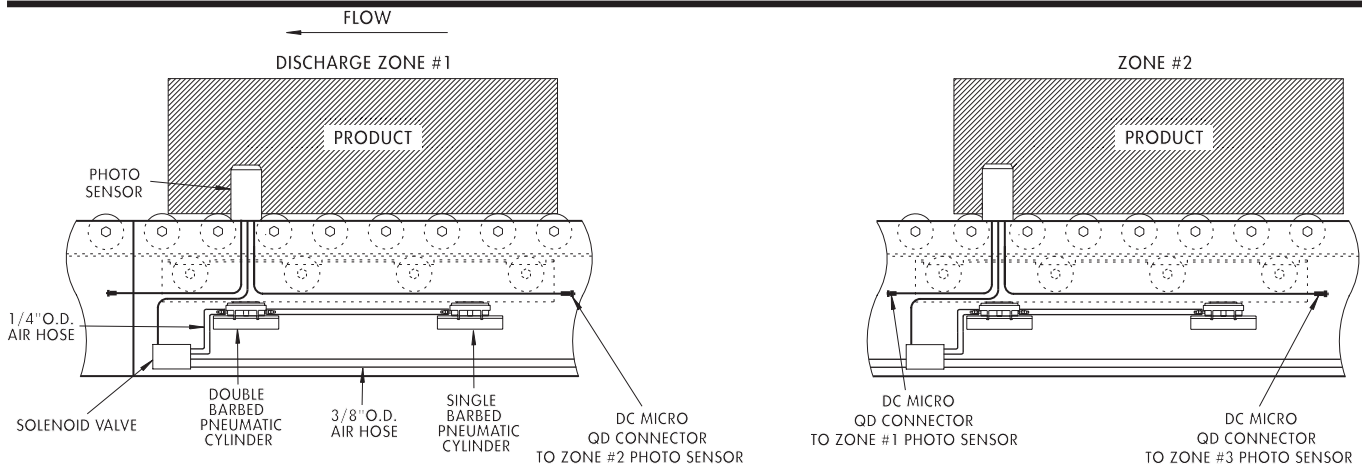
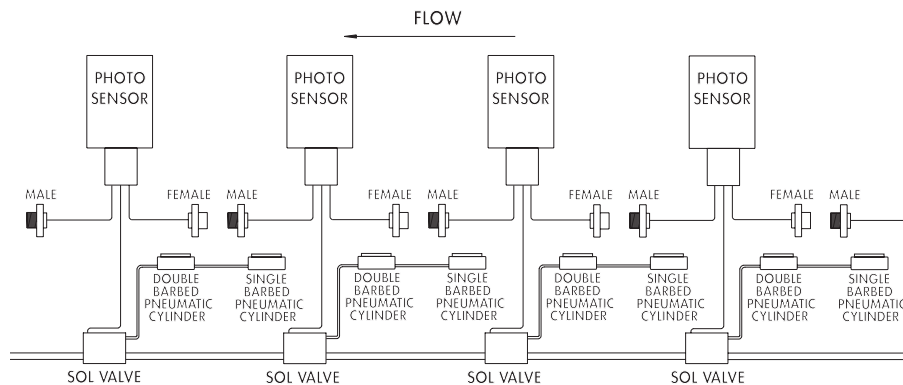

Photo sensors, reflectors, solenoid valves and pneumatic cylinders are shipped mounted, connected and tested on Smart Zone®. When mating individual Smart Zone® bed sections during field installation, two simple connections are required, neither requiring any tools. First, photo sensors must be adjoined across bed sections via DC micro QD connectors, a

screw-type connection. The second connection involves 3/8" O.D. hose and solenoid valve. The hose is inserted in 3/8" quick connect push-in hose fitting on the solenoid valve.

When a product blocks discharge zone #1 photo sensor, a signal is delivered to the pneumatic cylinder in this zone which shifts the zone into accumulation mode.

The second product will stop moving when it blocks the photo sensor in zone #2 and so forth. A product cannot accumulate in a zone until a product is accumulated in the adjacent discharge zone.



WARNING: Electrical controls must include appropriate safety features (emergency stops, pull cords, switches, etc.) installed on unit for safe operation. Before conveyor start-up, all operators and other personnel coming in contact with unit must be properly trained and must have read accompanying Tech Handbook.

The standard mode of operation for Roach® Smart Zone® is zone singulation operation. The standard mode of product release for Smart Zone® is therefore, zone singulation release. Each product is accumulated in a separate zone on the conveyor. A product advances into the adjacent discharge zone when that zone is clear. The photo sensor clears and a single product advances.

To off-load utilizing standard zone singulation operation, operator uses a relay contact to the conveyor power supply to discharge a single product. The Smart Zone® power supply is a 100 watt 24VDC enclosure.

Finally, an operator may off-load Smart Zone® by simply removing a product from the discharge zone, which allows

another product to advance into the discharge zone when the previous product clears that zone.

NOTE: Maximum air line pressure must not exceed 30PSI.

SMART ZONE® SLUG RELEASE OFF-LOADING / SLUG LOADING

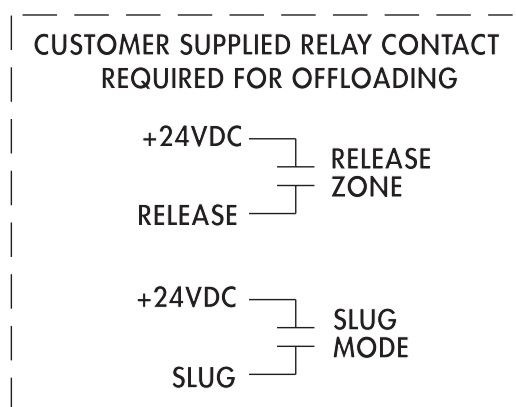

WARNING: Electrical controls must include appropriate safety features (emergency stops, pull cords, switches, etc.) installed on unit for safe operation. Before conveyor start-up, all operators and other personnel coming in contact with unit must be properly trained and must have read accompanying Tech Handbook.

A common feature for Smart Zone® conveyors is slug release or slug off-loading. When utilizing slug off-loading, all zones are powered at once to release all accumulated products. Likewise, once the slug mode is selected from Smart Zone® power supply via customer-supplied relay contact, the conveyor remains in slug mode for both slug off-loading and slug loading.

Slug loading allows a group or "slug" of products to accumulate on Smart Zone® at once. These products will continue in motion until either an additional sensor (not supplied with Smart Zone®) stops

Smart Zone® from continuously running or customer-supplied relay contact switches power supply from slug mode.

TECHNICAL - SMART ZONE® MODELS UP TO 50' W/ DISCHARGE POWER SUPPLY

TYPICAL ZONE-TO-ZONE CONNECTION FOR UP TO 25 ZONES OR 50' MAX.

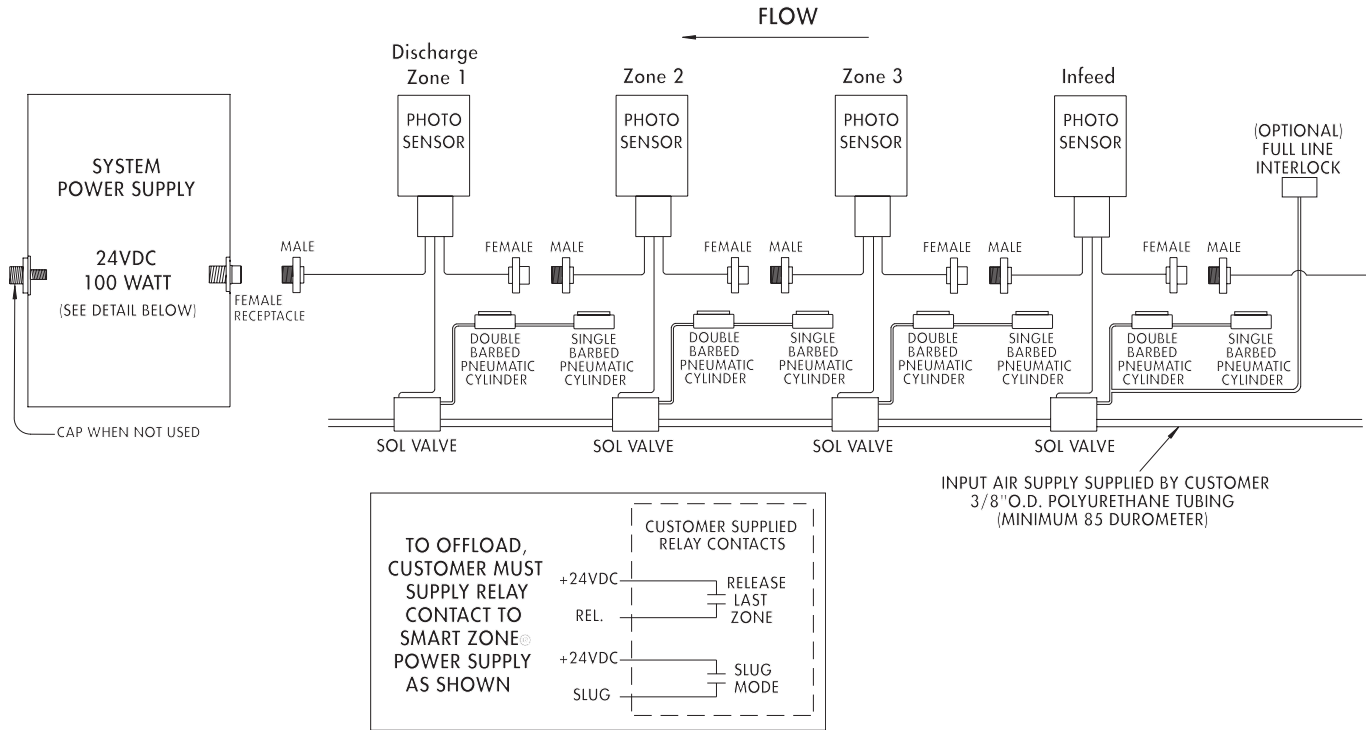

SMART ZONE® POWER SUPPLY AND PHOTO SENSOR DETAILS

SMART ZONE® POWER SUPPLY

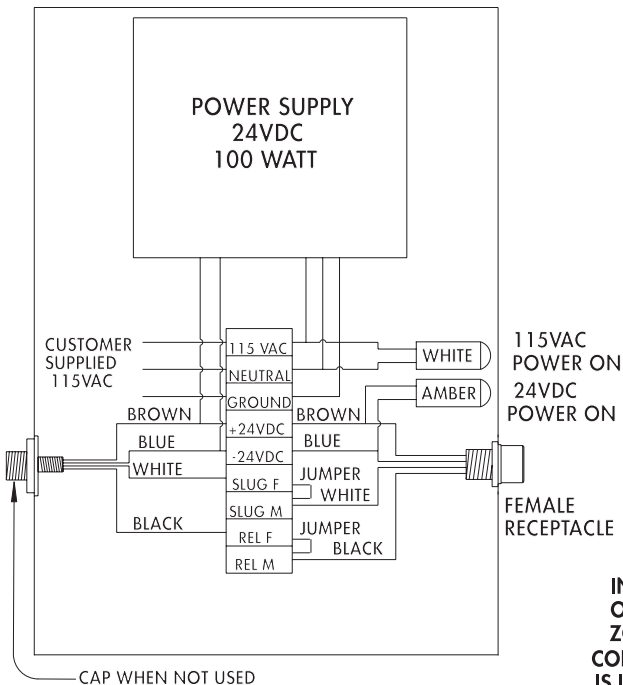

SMART ZONE® PHOTO SENSOR

EACH PHOTO SENSOR FEATURES BUILT-IN TIME DELAY OF 0-10 SECONDS. USE SCREWDRIVER IN SLOT SHOWN TO ADJUST REQUIRED TIME DELAY. TURN CLOCKWISE TO INCREASE TIME DELAY (10 SECONDS MAXIMUM).

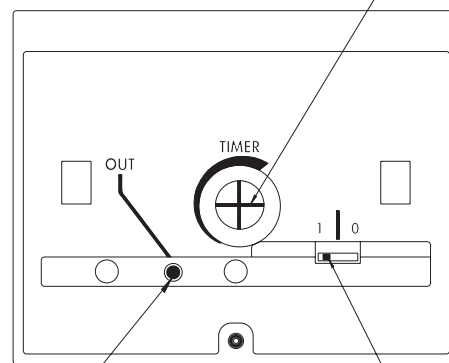

DIP SWITCH SHOULD ALWAYS BE SET TO POSITION 1 FOR MODEL ZPA SMART ZONE®. THIS FEATURE DIRECTS SOLENOID VALVE TO ENERGIZE FOR PROPER OPERATION.

INDICATOR LIGHT INDICATES SOLENOID VALVE OUTPUT. SOLENOID VALVE IS ENERGIZED AND ZONE IS RUNNING WHEN INDICATOR LIGHT IS CONTINUOUSLY LIT. ZONE IS NOT RUNNING AND IS IN ACCUMULATION MODE WHEN LIGHT IS OUT.

TYPICAL ZONE-TO-ZONE CONNECTION FOR UP TO 50 ZONES OR 100' MAX.

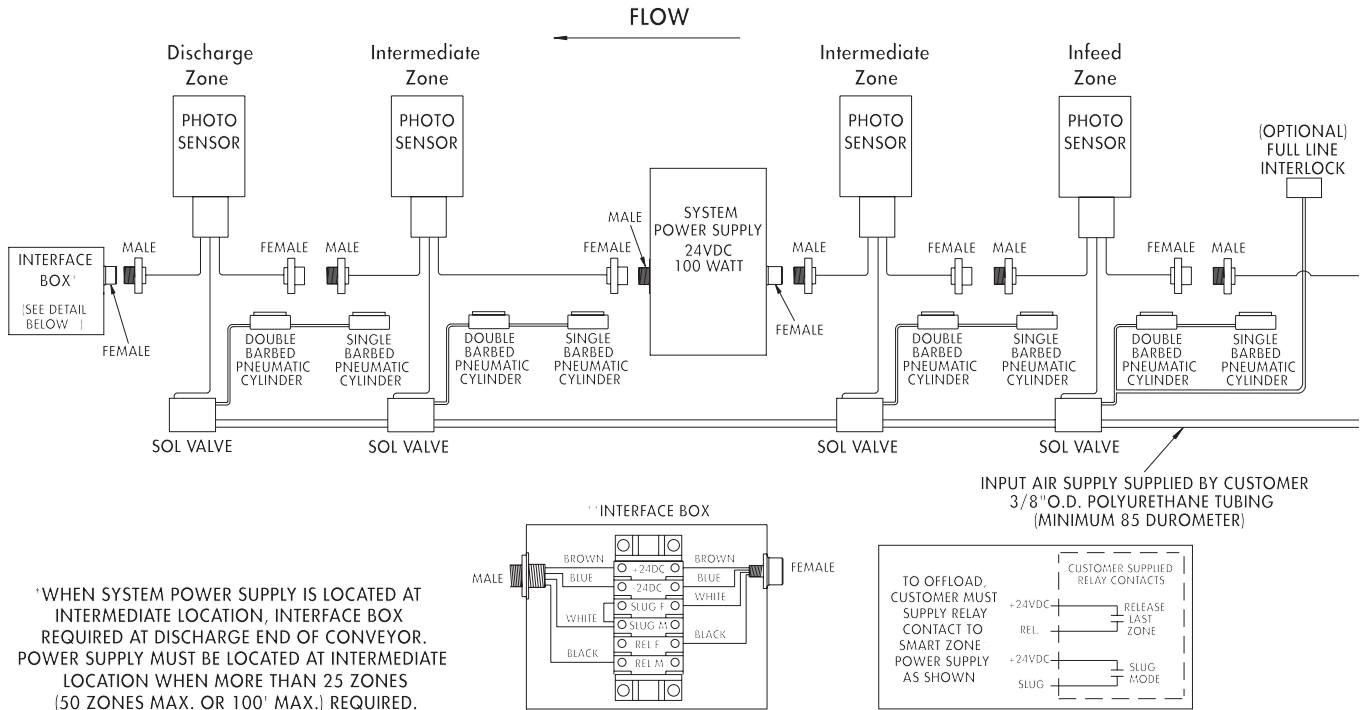

SMART ZONE® OPERATOR-CONTROLLED WORK ZONES (OPTIONAL)

TYPICAL CONNECTION FOR OPERATOR-CONTROLLED WORK STATION

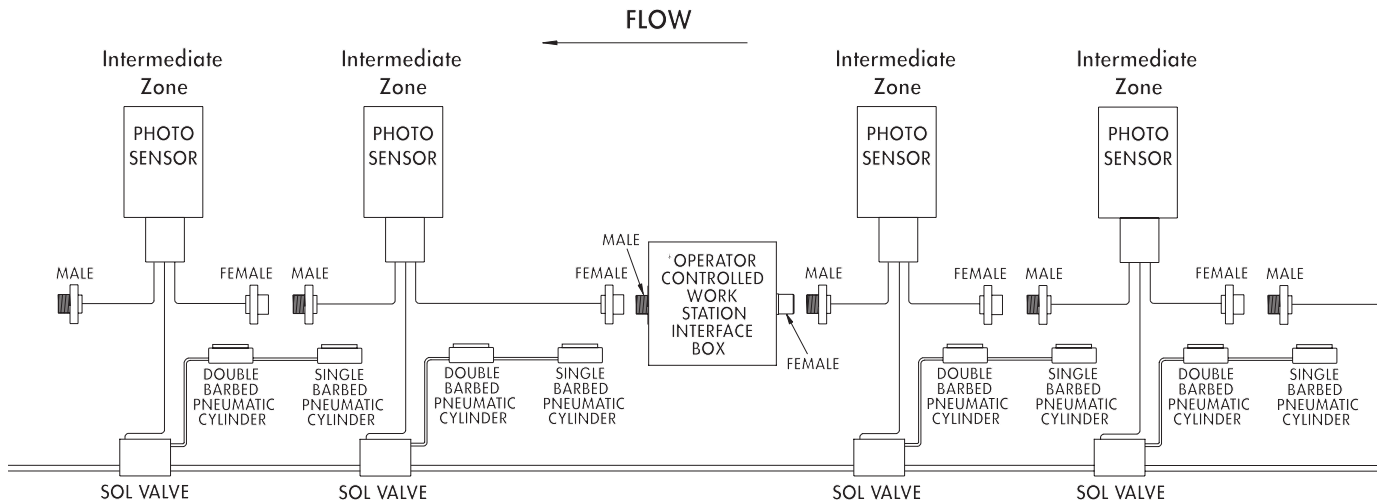

MAINTENANCE SAFETY PRECAUTIONS BEFORE PERFORMING MAINTENANCE

CAUTION: Only trained personnel shall perform maintenance functions. Before maintenance operations are performed, conveyor must be shut "OFF" and disconnects locked in the "OFF" position to prevent unit from unauthorized start-up.

One of the most important guidelines for maximizing conveyor operation and personnel safety is to implement a regular maintenance schedule and train personnel on the appropriate needs of the specific unit.

Only trained personnel shall perform maintenance functions. Before maintenance operations are performed, conveyor must be shut "OFF" and disconnects locked in the "OFF" position to prevent unit from unauthorized start-up during maintenance. All personnel should be informed of the safety procedures associated with unit maintenance and performance.

Do not perform any work on conveyors or conveyor system

while in operation unless it is impossible to otherwise conduct adjustment, lubrication or other maintenance function. Only experienced, trained personnel possessing advanced hazards-training should attempt such critical operations.

MAINTENANCE AND FOLLOW-UP DETAILS

CAUTION: Only trained personnel shall perform maintenance functions. When maintenance is completed, only authorized personnel shall be permitted to start conveyor following maintenance or other emergency shut-off.

While performing maintenance do not wear loose clothing. Immediately report any hazardous conditions-sharp edges, pinch (or nip) points or other conditions that may result when several manufacturers supply machinery which may create operating hazards.

When using mechanical aids such as hoists, cables, or cranes exercise extreme caution to prevent damage to conveyors or other integrated machinery which may create a working hazard when maintenance is completed and units are in operation.

Clean up any spilled lubricants or other materials used in the maintenance process or those which may be deposited during unit operation. Eliminating poor housekeeping practices increases unit efficiency while creating safer personnel working conditions.

After maintenance, conduct visual inspection to ensure that all safety devices and guards have been replaced. Confirm that all

units are clear of tools, debris or other items. Before starting conveyor, check condition of unit caution labels (see "CAUTION LABELS" at front of handbook). If labels have been destroyed or are not clearly legible, call 870.483.7631 to receive replacement labels. Placement of caution labels is critical to avoid unauthorized unit operation which may result in hazardous working conditions for all related personnel coming in contact with conveyor.

Warn personnel that conveyor is being prepared for start-up and to stay clear of unit. Do not start conveyor until all personnel are clear. When maintenance is completed, only authorized personnel shall be permitted to start conveyor following maintenance or other emergency shut-off.

MAINTENANCE AND LUBRICATION

MAINTENANCE SCHEDULES

MODEL NO. _____

WEEKLY RECOMMENDED MAINTENANCE SCHEDULE*	
COMPONENT	DETAIL OF MAINTENANCE
Belting	Inspect belt tracking.
Pillow Block/Flange Bearings	Lubricate in dirty, dusty or moist/wet conditions.
Unit Safety Check	Confirm placement of all guards, pop out rollers, warning labels & check for loose bolts, nip points & other hazards.

WEEKLY RECOMMENDED MAINTENANCE SCHEDULE*	
COMPONENT	DETAIL OF MAINTENANCE
Gear Reducer	Check for leaks.
Belting	Check for proper operating tension & laced connections.
V-Belt Drive Belt	Check for proper operating tension & overall wear.
Drive Sheaves	Check and re-tighten set screws & check for overall wear.
Pillow Block/Flange Bearings	Lubricate (normal conditions)
Drive Chain	Check for proper operating tension & for overall wear & lubricate.
Drive Sprockets	Check for overall wear & re-tighten set screws.

WEEKLY RECOMMENDED MAINTENANCE SCHEDULE*	
COMPONENT	DETAIL OF MAINTENANCE
Gear Reducer	Check for leaks.
Drive Chain	Clean (brush in solvent) & re-lubricate by applying lubricant to inside of chain with brush or spout can at 2000 hour intervals.
Motor	Check & clean motor ventilation openings at 500 hour intervals. Check misc. operating conditions (normal heat & noise)

*All charts are for guidelines in normal operating or 'as noted' conditions. Severe applications may warrant additional maintenance.

MAINTENANCE AND LUBRICATION

RECOMMENDED LUBRICANTS

MISC. LUBRICANTS	
LUBRICANT	BRAND/DESCRIPTION
General Purpose Grease (For -30°F to 300°F operation)*	Shell Dolium R (Shell Oil Co.) (or suitable equivalent)
For Extreme Temperature Operation (-90°F to 350°F operation)*	Mobiltemp SHC-32 (Mobil Oil Corp.) (or suitable equivalent)
Washdown Application* (-30°F to 225°F operation) (May require special consideration-consult factory)	Shell Alvania No. 3 (Shell Oil Co.) (or suitable equivalent)
General Purpose Oil	SAE 10; SAE 20 or SAE 30

*NOTE: Temperatures listed indicate the nominal operational temperature for the specific lubricant listed. This does not imply that the bearing housing, seals or any other conveyor unit component is rated to operate in this specific temperature range or environment. 250°F is the maximum operating temperature for standard bearing lubricants and bearing components. Although various lubricants may enhance bearing operation, special-order bearings may be required to achieve optimal bearing performance. For additional information, consult factory.

TROUBLE SHOOTING AND REPLACEMENT PARTS

TROUBLE SHOOTING / SERIAL PLATE

TROUBLE SHOOTING		
TROUBLE	PROBABLE CAUSE	REMEDY
Motor & gear reducer running excessively hot, repeated stalling or hard to start	A. Drag on conveyor B. Frozen sprocket C. Frozen roller D. Overload E. Electrical	A. Inspect entire conveyor for obstruction causing drag on chain. B. Check and inspect all sprockets and bearings. Replace sprockets failing to rotate or that are difficult to rotate. C. Check all rollers for rotation. D. Reduce cause and/or increase motor horsepower. E. Check wiring and circuits, take ampere reading, replace motor if necessary.
Motor & gear reducer makes excessive noise	A. Damaged gears B. Faulty bearing	A. Replace unit. B. Replace bearing.
Drive chain, conveying chain or sprockets experience excessive wear	A. Excessive chain tension B. Sprockets misaligned C. Chain not lubricated D. Damaged sprocket or chain E. Misalignment of chain guard F. Dirty chain	A. Reduce chain tension. B. Realign with straight edge across sprocket faces. C. Lubricate chain with approved lubricant, wipe away excess lubricant. D. Replace damaged component. E. Adjust chain guard assembly as necessary. F. Clean thoroughly and lubricate with approved lubricant.
Drive chain, conveying chain or sprockets make excessive noise	A. Insufficient chain tension B. Chain not adequately lubricated C. Sprockets misaligned	A. Adjust chain tension. B. Lubricate chain with approved lubricant, wipe away excess lubricant. C. Realign sprockets with straight edge across sprocket faces.
Pulsating chain	A. Insufficient chain tension B. Misalignment of chain guard C. Overload	A. Adjust chain tension. B. Adjust chain guard assembly as necessary. C. Inspect for obstruction to or drag on conveyor.
Broken chain	A. Frozen bearing or sprocket shaft B. Worn or damaged chain C. Obstructed or jam	A. Inspect for damaged bearings, replace if necessary. Replace links as required. B. Replace chain as required. C. Remove obstruction to clear jam.
Sprocket loose on shaft	A. Loose set screws B. Worn or damaged key	A. Realign sprockets with straight edge and tighten set screws. B. Replace with new key.
Excessive slack in chain	A. Normal wear	A. Expect rapid chain growth in first two weeks of operation. Adjust chain tension.



ROACH CONVEYORS
808 HIGHWAY 463
TRUMANN, AR 72472
TEL 870-483-7631

SERIAL NO.

123456

ORDERING REPLACEMENT PARTS

To order any replacement parts or when calling for assistance with any powered conveyor, ALWAYS provide the unit serial number. Shown at actual size, this aluminum plate is placed on the conveyor frame near location of drive assembly.

To order replacement parts or add-on components, contact the Roach® distributor who originally furnished conveyor if possible. If this is not possible, contact the national sales office at 870-483-7631 for the name of the authorized Roach distributor in your area. Have unit model number and serial number BEFORE calling. Refer to unit drawings (in rear section of handbook) for part numbers if ordering replacement parts.

MODEL 196ZPA

PARTS LIST FOR UNIT WITH 4" AND 8" END DRIVE

Specify Unit Serial Number when ordering replacement parts to ensure proper allocation of components.
Recommended Spare Parts are shown in red. Charted are item no. and part description
 When ordering use example below.

Example: Need a replacement end drive plate for an 8" end drive assembly.
 Side Mounted.

Part No: SN 123456 - 25 - (left Hand) or SN123456 - 26 (Right Hand)

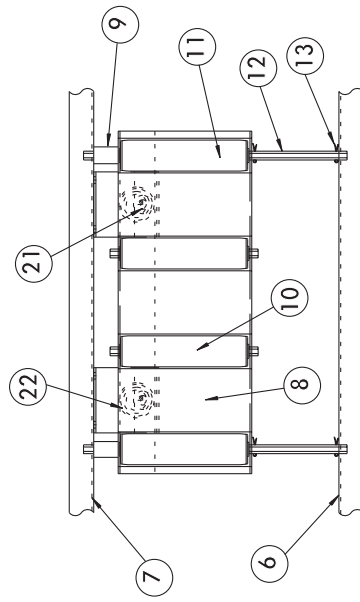

WARNING:
 When installing below 7'-0 elevation, tread rollers must be designed to pop out.
 When installing at 7'-0" or higher elevation, tread rollers must NOT be allowed to pop out.

ITEM #	DESCRIPTION	ITEM #	DESCRIPTION
1	196ZPA Intermediate Bed Section	23	8" End Drive Assembly
2	1.9 Return Roller Bracket	24	8" End Drive Pulley
3	Splice Plate	25	8" End Drive Plate (Left Hand)
4	Frame Cross Brace	26	8" End Drive Plate (Right Hand)
5	196S Roller	27	4 Hole Flange Bearing W/1.7/1.6" Bore
6	Left Hand Side Channel	28	196S Grooved Roller
7	Right Hand Side Channel	29	Round Drive Belt
8	Pressure Channel	30	1.9 Roller Adjustment Bracket
9	Pressure Channel Space 1/2" PVC Sch.	31	4" End Take-Up Assembly
10	196S Roller 8" BF	32	4" Take-Up Pulley
11	196S 8" BF Less Shaft	33	4" Take-Up Plate
12	Pressure Roller Shaft	34	Take-Up Bearing Guide
13	1/8" x 1" Cotter Pin	35	Take-Up Bearing Assembly (Left Hand)
14	Chamber Mount Bracket	36	Take-Up Bearing Assembly (Right Hand)
15	Clipper Valve Mount	37	196S Grooved Roller
16	Nylon Sensor Arm	38	Round Drive Belt
17	196S Pivot Roller	39	Take-Up Butt Coupling
18	108G Sensor Roller	40	1/4" FRL W/Gauge (Not Shown)
19	Spring Mounting Angle	41	PVC-120 Belting
20	Extensions spring	42	Reducer Push Plate Assembly
21	Actuator Stop	43	Underneath Motor Base Plate
22	Roach® Air Camber	44	End Drive Chain Guard Assembly
23	4" End Drive Assembly	45	#50 (thru 1-1/2 HP) or #60 Roller Chain
24	4" Drive Pulley	46	Pulley Drive Sprocket
25	4" End Drive Plate (Left Hand)	47	Gear Reducer Drive Sprocket
26	4" End Drive Plate (Right Hand)	48	Gear Reducer
27	3 Hole Flange Bearing W/1.3/1.6" Bore	49	Motor
28	196S Grooved Roller		
29	Round Belt		
30	1.9 Roller Adjustment Bracket		

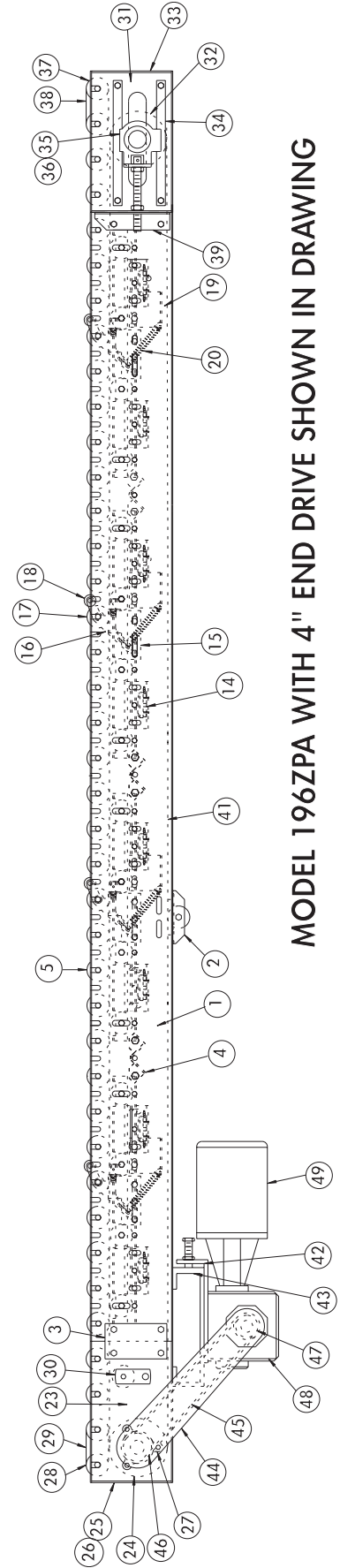

MODEL 196ZPA WITH 4" END DRIVE SHOWN IN DRAWING

MODEL SZ196ZPA

PARTS LIST FOR UNIT WITH 4" AND 8" END DRIVE

Specify Unit Serial Number when ordering replacement parts to ensure proper allocation of components.
Recommended Spare Parts are shown in red. Charted are item no. and part description
 When ordering use example below.

Example: Need a replacement center drive plate for a 4" center drive assembly.
 Part No: SN 123456 - 26 (Left Hand) or SN123456 - 27 (Right Hand)

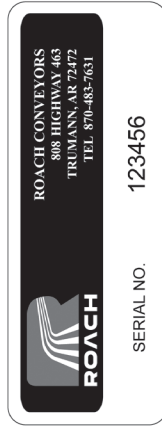

WARNING:
 When installing below 7'-0" elevation, tread rollers must be designed to pop out
 When installing at 7'-0" or higher elevation, tread rollers must NOT be allowed to pop out.

ITEM #	DESCRIPTION	ITEM #	DESCRIPTION
1	196ZPA Intermediate Bed Section	33	251S Roller
2	1.9 Return Roller Bracket	34	Snub Roller Adjustment Bracket
3	Splice Plate	23	8" Center Drive Assembly
4	Frame Cross Brace	24	8" Drive Pulley
5	196S Roller	25	4" Take-Up Pulley
6	Left Hand Side Channel	26	8" Center Drive Plate (Left Hand)
7	Right Hand Side Channel	27	8" Center Drive Plate (Right Hand)
8	Pressure Channel	28	8" Center Drive Belt Guard
9	Pressure Channel Space 1/2" PVC Sch. 40	29	8" Center Drive Belt Guard
10	196S Roller 8" BF	30	Center drive Take-Up Bearing Guide
11	196S 8" BF Less Shaft	31	Take-Up Bearing Assembly
12	Pressure Roller Shaft	32	4 Hole Flange Bearing W/1-7/16" Bore
13	1/8" x 1" Coller Pin	33	251S Roller
14	Chamber Mount Bracket	34	Snub Roller Adjustment Bracket
15	Clippard Valve Mount	35	4" Fixed End Assembly
16	Nylon Sensor Arm	36	4" Fixed End Pulley
17	196S Pivot Roller	37	4" Fixed End Plate
18	108G Sensor Roller	38	196S Grooved Roller
19	Spring Mounting Angle	39	3 Hole Flange Bearing W/1-3/16" Bore
20	Extensions Spring	40	Round Drive Belt
21	Actuator Stop	41	1.9 Roller Adjustment Bracket
22	Roach® Air Camber	42	1/4" FRL W/Gauge (Not Shown)
23	4" Center Drive Assembly	43	PVC-120 Belling
24	4" Drive Pulley	44	Reducer Push Plate Assembly
25	4" Take-Up Pulley	45	Underneath Motor Base Plate
26	4" End Drive Plate (Left Hand)	46	Center Drive Chain Guard Assembly
27	4" End Drive Plate (Right Hand)	47	#50 (thru 1-1/2 HP) or #60 Roller Chain
28	4" Center Drive Belt Guard	48	Gear Reducer Drive Sprocket
29	4" Center Drive Belt Guard	49	Pulley Drive Sprocket
30	Center Drive Take-Up Bearing Guide	50	Gear Reducer
31	Take-Up Bearing Assembly	51	Motor
32	3 Hole Flange Bearing W/1-3/16" Bore		

MODEL 196ZPA

PARTS LIST FOR UNIT WITH 4" AND 8" CENTER DRIVE

Specify Unit Serial Number when ordering replacement parts to ensure proper allocation of components-
Recommended Spare Parts are shown in red. Charted are item no. and part description
 When ordering use example below.

Example: Need a replacement center drive plate for a 4" center drive assembly.

Part No: SN 123456 · 26 (Left Hand) or SN123456 · 27 (Right Hand)



WARNING:
 When installing below 7'-0" elevation, tread rollers must be designed to pop out
 When installing at 7'-0" or higher elevation, tread rollers must NOT be allowed to pop out.

ITEM #	DESCRIPTION	ITEM #	DESCRIPTION
1	196ZPA Intermediate Bed Section	33	251S Roller
2	1.9 Return Roller Bracket	34	Snub Roller Adjustment Bracket
3	Splice Plate	23	8" Center Drive Assembly
4	Frame Cross Brace	24	8" Drive Pulley
5	196S Roller	25	4" Take-Up Pulley
6	Left Hand Side Channel	26	8" Center Drive Plate (Left Hand)
7	Right Hand Side Channel	27	8" Center Drive Plate (Right Hand)
8	Pressure Channel	28	8" Center Drive Belt Guard
9	Pressure Channel Space 1/2" PVC Sch. 40	29	8" Center Drive Belt Guard
10	196S Roller 8" BF	30	Center Drive Take-Up Bearing Guide
11	196S 8" BF Less Shaft	31	Take-Up Bearing Assembly
12	Pressure Roller Shaft	32	4 Hole Flange Bearing W/1.7/16" Bore
13	1/8" x 1" Cotter Pin	33	251S Roller
14	Chamber Mount Bracket	34	Snub Roller Adjustment Bracket
15	Clippard Valve Mount	35	4" Fixed End Assembly
16	Nylon Sensor Arm	36	4" Fixed End Pulley
17	196S Pivot Roller	37	4" Fixed End Plate
18	108G Sensor Roller	38	196S Grooved Roller
19	Spring Mounting Angle	39	3 Hole Flange Bearing W/1.3/16" Bore
20	Extensions Spring	40	Round Drive Belt
21	Actuator Slop	41	1.9 Roller Adjustment Bracket
22	Roach® Air Camber	42	1/4" FRL W/Gauge (Not Shown)
23	4" Center Drive Assembly	43	PVC-120 Belting
24	4" Drive Pulley	44	Reducer Push Plate Assembly
25	4" Take-Up Pulley	45	Underneath Motor Base Plate
26	4" End Drive Plate (Left Hand)	46	Center Drive Chain Guard Assembly
27	4" End Drive Plate (Right Hand)	47	#50 (thru 1-1/2 HP) or #60 Roller Chain
28	4" Center Drive Belt Guard	48	Gear Reducer Drive Sprocket
29	4" Center Drive Belt Guard	49	Pulley Drive Sprocket
30	Center Drive Take-Up Bearing Guide	50	Gear Reducer
31	Take-Up Bearing Assembly	51	Motor
32	3 Hole Flange Bearing W/1.3/16" Bore		

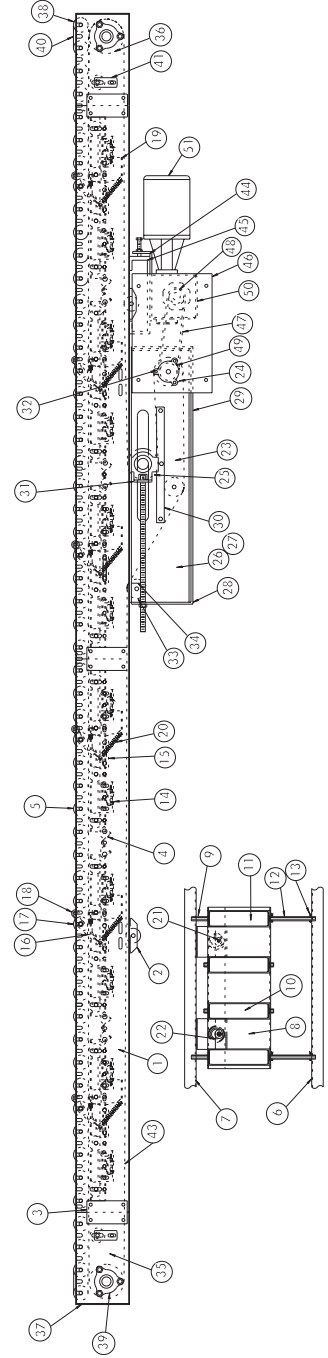

MODEL 196ZPA WITH 4" CENTER DRIVE SHOWN IN DRAWING

MODEL SZ196ZPA

PARTS LIST FOR UNIT WITH 4" AND 8" CENTER DRIVE

ITEM #	DESCRIPTION	ITEM #	DESCRIPTION
1	4" center drive assembly	17	196ZPA frames 96" long (LH/RH)
2	4" fixed end plate assembly (LH/RH)	18	Reflector tape 3" long
3	Motor drive assembly	19	Power supply assembly
4	Smartzone Photocell	20	1" roller bearing
5	Bolt-in crossbrace	21	White ruther glide
6	192S-25" BF	22	6" wide PVC #120 belt
7	192S-25" BF grooved roller	24	Pressure channel spacer
8	196S roller	25	4" fixed end pulley
9	Pressure roller shaft	26	Center drive chain guard assembly
10	Chamber mount	27	Brake chamber mount
11	ZPA pressure channel	28	ZPA brake channel assembly
12	196S return rollers	29	Splice plate
13	Return roller bracket	30	1.9 idler keeper
14	Photoeye/valve mount	31	1-3/16" bore 3-hole flange bearing
15	Photoeye guard	32	Plumbing
16	Guard rail spacers		

Specify Unit Serial Number when ordering replacement parts to ensure proper allocation of components.
Recommended Spare Parts are shown in red. Charted are item no. and part description
 When ordering use example below.

Example: Need a replacement center drive plate for a 4" center drive assembly.

Part No: SN 123456 · 26 (Left Hand) or SN123456 · 27 (Right Hand)



WARNING:
 When installing below 7'-0" elevation, tread rollers must be designed to pop out
 When installing at 7'-0" or higher elevation, tread rollers must NOT be allowed to pop out.

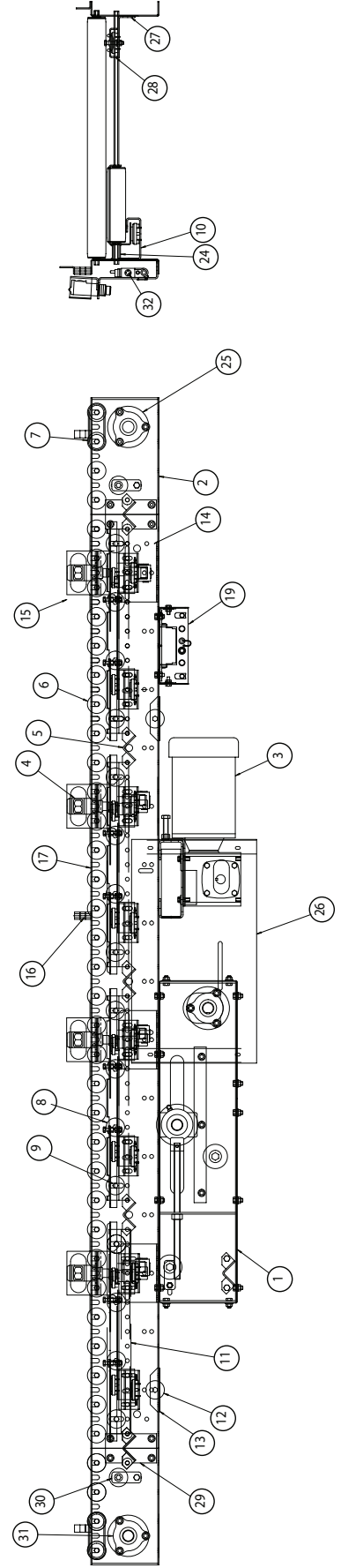



ROACH CONVEYORS

WARRANTY

- Materials used by Roach Conveyors are of good quality.
- Any part proving to be defective in materials or workmanship upon Roach inspection, will be replaced at NO cost, FOB, Trumann, Arkansas, for one year. Installation expense will be paid by others.
- Roach liability includes furnishing said part or parts; Roach is not liable for consequential damages, such as loss of profit, delays or expenses incurred by failure of said part or parts.
- Failure due to abuse, incorrect adjustments, exposure to corrosive or abrasive environment or operation under damp conditions does not constitute failure due to defects in workmanship or materials.
- Component parts not manufactured by Roach (motors, gear reducers, etc.) will be repaired or replaced at the option of their manufacturer. Contact nearest authorized service center for all warranty claims.

NOTE: Motors or gear reducers tampered with before inspection shall be considered free of ALL Warranty Claims.

--All specifications are subject to change without notice--
--Drawings are intended for illustration ONLY and are not to scale--

808 HIGHWAY 463
TRUMANN, ARKANSAS 72472-1310
Tel 870-483-7631 Fax 870-483-7049
info@roachconveyors.com
www.roachconveyors.com



808 HIGHWAY 463
TRUMANN, ARKANSAS 72472-1310
Tel 870-483-7631 Fax 870-483-7049
roachconveyors.com