



# OWNER'S MANUAL



## Slat Conveyors

Model 608SL

DO NOT OPERATE BEFORE READING THIS HANDBOOK  
KEEP IN A SAFE PLACE - DO NOT DISCARD

# TECH HANDBOOK FOR 608SL

## TABLE OF CONTENTS

TECH HANDBOOK FOR SLAT CONVEYOR .....	2	MAINTENANCE AND LUBRICATION .....	9
-Warning Labels .....	2	-Maintenance Schedules .....	9
CAUTIONS, WARNINGS AND HAZARDS .....	3	-Recommended Lubricants .....	10
-Introduction .....	3	-Misc. Lubricants .....	11
-Cautions, Warnings and Hazards.....	3	-Report on Miscellaneous Maintenance Performed .....	12
SAFETY INFORMATION / RECEIVING AND INSPECTION .....	4	TROUBLE SHOOTING AND REPLACEMENT PARTS .....	13
-Important Safety Guidelines.....	4	-Trouble Shooting / Serial Plate.....	13
-Shortages, Damages and Return Authorizations.....	4	PARTS LISTS FOR SLAT CONVEYORS .....	14
GENERAL INSTALLATION INFORMATION .....	5	-Parts List for 608SL.....	14
-Slat Conveyor Set-Up.....	5	-Notes .....	15
TECHNICAL .....	5	WARRANTY .....	16
-Maintaining Proper Carrier Chain Tension.....	5		
START-UP PROCEDURES .....	6		
-Drive Chain and Sprocket Alignment.....	6		
-Drive Chain and Sprocket Tension .....	6		
-Gear Reducer Vent plug .....	7		
-Preparing for Initial Start-Up .....	7		
MAINTENANCE SAFETY PRECAUTIONS .....	8		
-Before Performing Maintenance .....	8		
-Maintenance and Follow-Up Details .....	8		

All specifications are subject to change without notice \* Drawings are intended for illustration ONLY and are not to scale

## WARNING LABELS



ABOVE: Label attached to all protective guards (drives, roller guards, etc.)



ABOVE: Label placed near all pulleys (center drives, end drives, tail pulleys)

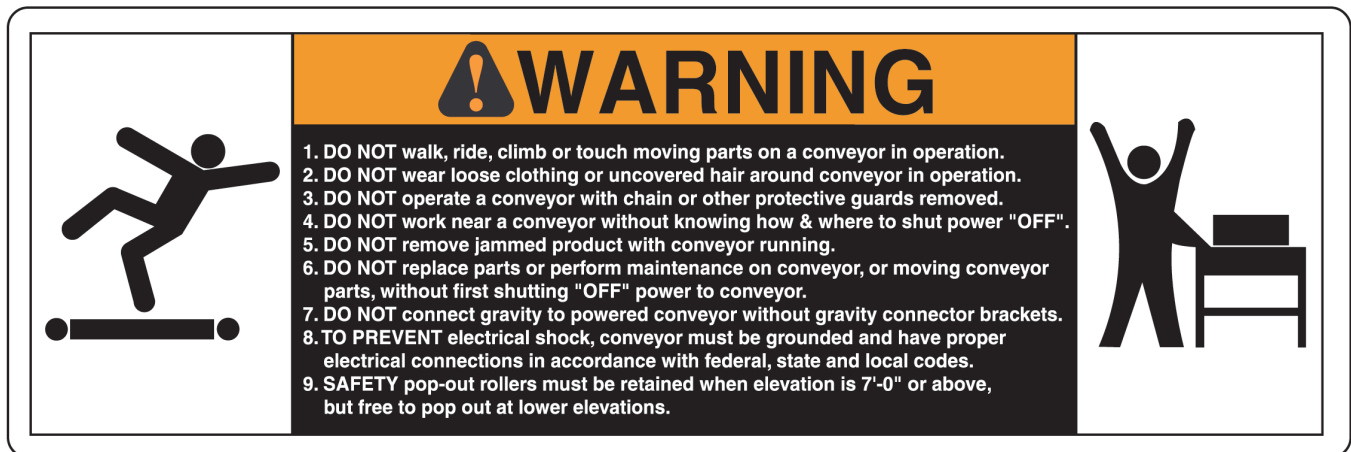

ABOVE: Label placed near all drive assemblies and at 30' intervals

# CAUTIONS, WARNINGS AND HAZARDS INTRODUCTION

This manual was prepared as a “how-to-guide” for installers, end-users and maintenance personnel. It is also intended to educate both owner (purchaser) and all individuals working around the unit, of potential hazards.

With proper installation and maintenance, conveyors are essential for achieving a variety of functions essential in today’s industrial marketplace. By following a simple, periodic maintenance schedule, the life of a typical conveyor (or, most any type of machinery-including our automobiles!) will increase when com-

pared to a similar unit in an application receiving little or no maintenance. You may find that a conveyor can become your best workplace friend by following simple safety guidelines. Failure to follow even the most basic safety suggestions can result in serious personal injury.

Conveyors contain many moving parts-pulleys, belting, chains, sprockets, shafts, rollers, etc. Therefore, it is imperative to become familiar with basic unit operation and know all points of potential hazards.

Remember, when working around or near conveyors (and any industrial machinery)

it is your responsibility to become familiar with the unit, to know potential hazards (many are noted with caution labels) and to operate unit in strict accordance with the safety guidelines in this manual.

Keep this manual in a safe place for future reference. It should be placed where appropriate personnel may maintain proper maintenance and records.

This manual must be read by all new users before operating or working near this unit.

## **WARNING**

**DO NOT OPERATE BEFORE READING THIS MANUAL!  
KEEP IN SAFE PLACE--DO NOT DISCARD!**

# CAUTIONS, WARNINGS AND HAZARDS

## **WARNING**

 NEVER connect belt conveyors directly to gravity conveyors, machinery or fixtures without using connector brackets & pop out roller.

 ALWAYS anchor permanent supports to floor (or mounting surface). Use 3/8" x 2-1/2" (or longer) wedge anchors for permanent installation in concrete flooring.

 It is the responsibility of the customer and installation personnel to supply and install net or mesh guarding on overhead mounted conveyors to prevent product and/or debris from falling to floor in areas where required.

 If belt conveyor pulleys are adjusted during installation or maintenance, nip point guard (at drive end on end drive unit) must be readjusted. Nip point guard (take-up end) is automatically adjusted when take-up pulley is adjusted. Nip point guards at both ends of conveyor (center drive) must be readjusted. Center drive guards MUST be replaced after installation or maintenance.

 Before unit is ready for operation, snub roller guard (cover) must be adjusted to ensure safe unit operation.

 Belt lacing must be kept in good condition for safe work environment.

 To check drive sprocket alignment, shut “OFF” and lock out power source before attempting any adjustments.

 To check drive sprocket tension, shut “OFF” and lock out power source before any adjustments are attempted.

 Electrical controls must be designed by a qualified electrical engineer to ensure that appropriate safety features (emergency stops, pull cords, switches, etc.) are installed on unit for safe operation. Before conveyor start-up, all operators and other personnel coming in contact with unit must be properly trained and must have read accompanying Tech Handbook.

 Upon start-up, if belt tracks to one side, turn unit “OFF”, lock out power source and confirm that conveyor is square and that all prime tracking components are square with bed. Belt tracking adjustments should be performed by trained personnel ONLY. Read section on “Belt Tracking” completely before attempting belt tracking adjustments.

 Only trained personnel shall perform maintenance functions. Before maintenance operations are performed, shut conveyor “OFF” and lock out power source to prevent unauthorized start-up. When maintenance is completed, only authorized personnel shall be permitted to start conveyor following maintenance or other emergency shut-off.





# SAFETY INFORMATION

## IMPORTANT SAFETY GUIDELINES

### **WARNING**

**WARNING:** All personnel coming in contact with this conveyor should be aware of the following safety guidelines BEFORE USING OR WORKING AROUND CONVEYOR. **NOTE:** ALWAYS notify Roach Manufacturing® whenever any conveyor is used in an application or condition other than was originally intended. Failure to notify Roach® may allow conveyor to be operated in a hazardous operating condition. Injuries resulting from negligence or violation of safety instructions hereby removes responsibility of product liability claims from Roach®.

 Do not operate conveyor with protective guards removed. This includes chain guards, belt guards, snub roller guards, center drive guards and any other safety guard.

 Do not walk, ride, climb, or touch moving parts on a conveyor in operation.

 Do not wear loose clothing or uncovered hair around conveyor.

 Do not work near conveyor without knowing how & where to shut power "OFF" and lock out power source.

 Do not remove jammed product with conveyor running.

 Do not replace parts or perform maintenance on conveyor, or moving conveyor parts, without first shutting "OFF" power to conveyor and locking out power source.

 Do not connect gravity to powered conveyor without safety gravity connector brackets.

 To prevent electrical shock, conveyor must be grounded, and have proper electrical connections in accordance with federal, state, and local codes.

 Safety pop out rollers in conveyors installed above 7'-0" elevation must be retained by guard rail, clips, etc. Safety pop out rollers must be allowed to pop out

when conveyors are installed at or below 7'-0" elevation.

 It is the responsibility of conveyor end-user to comply with all safety standards including OSHA and other federal, state, and local codes or regulations. Install protective guarding and other related safety precautionary equipment to eliminate hazardous operating conditions which may exist when two or more vendors supply machinery for related use.

 Any violation of above safety instructions hereby removes all product liability claims from Roach Manufacturing Corporation®.

## SHORTAGES, DAMAGES AND RETURN AUTHORIZATIONS

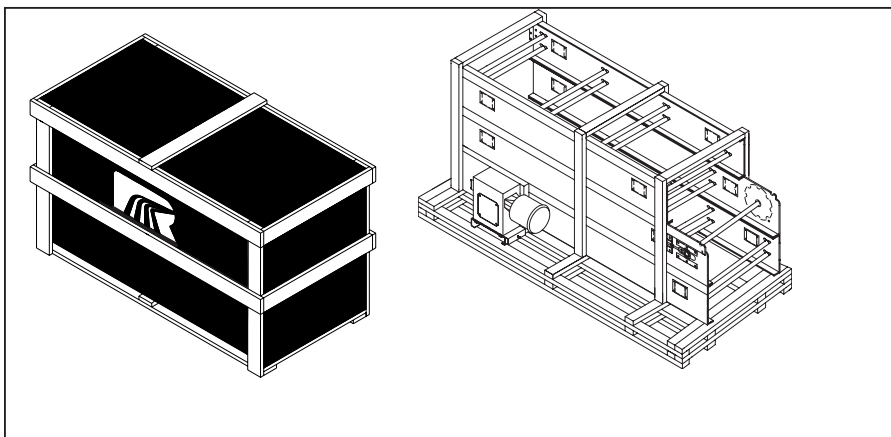

 **WARNING**

Never connect belt conveyors directly to gravity conveyors, machinery or fixtures without using connector brackets with pop out roller.

Before uncrating, check the quantity of items received against bill of lading to confirm that all material has been received. Examine the condition of the equipment to determine if any damage has occurred.

Also, it is possible that some items may become separated from the original shipment. Therefore, when receiving goods, it is imperative that the bill of lading (or,

accompanying freight documentation) be checked to ensure receipt of ALL units ordered including ALL accessories.

Damage and/or shortage in shipment should be reported immediately to both vendor and carrier. Obtain a signed damage report from carrier agent and send copy to vendor. Do not repair any damage before obtaining this report.

For damaged shipments, consult factory to determine if entire shipment must be returned to factory for repair or if an immediate order should enter production to produce a new, replacement shipment.

In illustration A above, slat conveyor is shown palletized with all bed sections mounted on crate which is prepared for shipment.



# GENERAL INSTALLATION INFORMATION

## SLAT SET-UP

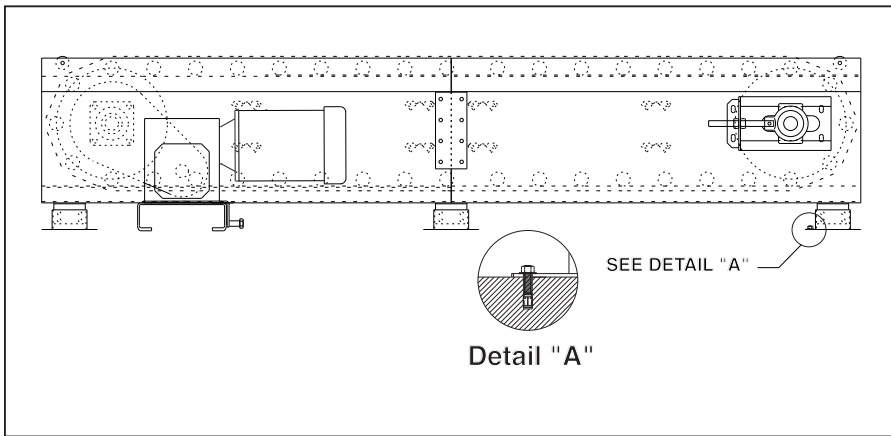

NOTE: Do not return goods to factory without prior, written return authorization. Unauthorized returns are subject to refusal at factory.

Once slat conveyor is uncrated, installation may begin. Locate unit in the actual installation area. Use mechanical hoist (fork truck or other available means) to raise conveyor bed sections to approximate installed elevation. Locate supports and mate bed sections of conveyor mounts in, with butt couplings (or splice plates).

Adjust elevation to top of conveyor by loosening bolts in supports uprights, raising or lowering conveyor and fully tightening bolts at desired elevation.

Next, level slat conveyor both across slats and lengthwise for proper unit operation. To level conveyor, loosen bolts in upright floor supports and level as required.

Adjustments may be required at both sides of conveyor supports and at each end of conveyor.

Complete support installation by tightening bolts in ALL supports before unit operation and lag support attachment plates to floor with lag bolts in support foot plate mounting holes (See Detail "A").

## TECHNICAL

### MAINTAINING PROPER CARRIER CHAIN TENSION

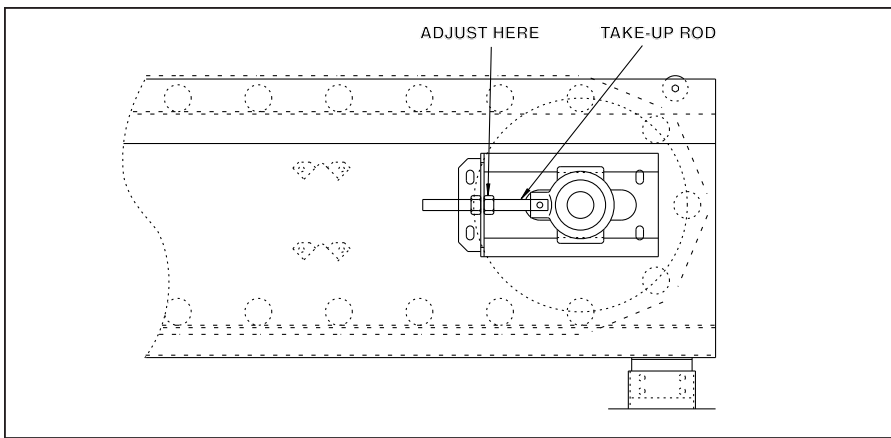

Maintaining proper carrier chain tension is vital to conveyor operation. Enough tension should be maintained so that drive sprocket does not slip under fully loaded conditions. It is perfectly normal for chain to stretch in varying operating conditions under

rated loading. Therefore, tension on slat chain must be monitored and adjusted as necessary.

To adjust Slat Conveyor take-up, adjust position of take-up rod as required. Remember to adjust each strand as required.

Do not operate with too much tension on chain strands, however. Over-tensioning may increase operating noise to unacceptable levels. Adjust to decrease tension on slat chain.

# START-UP PROCEDURES

## DRIVE CHAIN AND SPROCKET ALIGNMENT

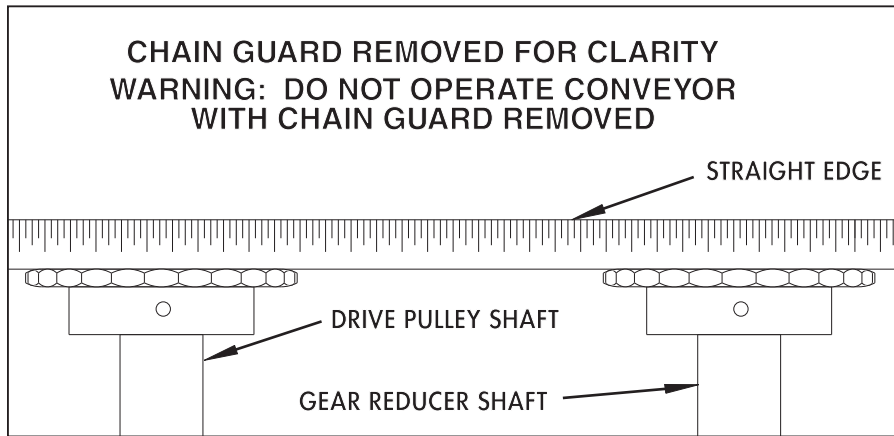

**WARNING**

To check drive sprocket alignment, it is imperative that conveyor is shut "OFF" and power source is locked out before any adjustments are attempted.

Set up and maintenance of drive sprocket and drive chain alignment is critical. A periodic visual inspection is recommended to confirm alignment of drive components (which includes both drive sprockets and drive chain). Should set screws become loose, drive sprockets are subject to excessive wear and ultimately, to untimely replacement.

To check drive sprocket alignment, it is imperative that conveyor is shut "OFF" and power source is locked out before any adjustments are attempted. Remove chain guard cover and place straight-edge (see illustration above) across face of both drive sprockets. If re-alignment is necessary, loosen set screws and adjust drive

sprockets as required. Remember to securely tighten set screws when alignment is complete.

Before replacing chain guard cover, check drive chain tension as described in following section, "Drive Chain and Sprocket Tension."

## DRIVE CHAIN AND SPROCKET TENSION

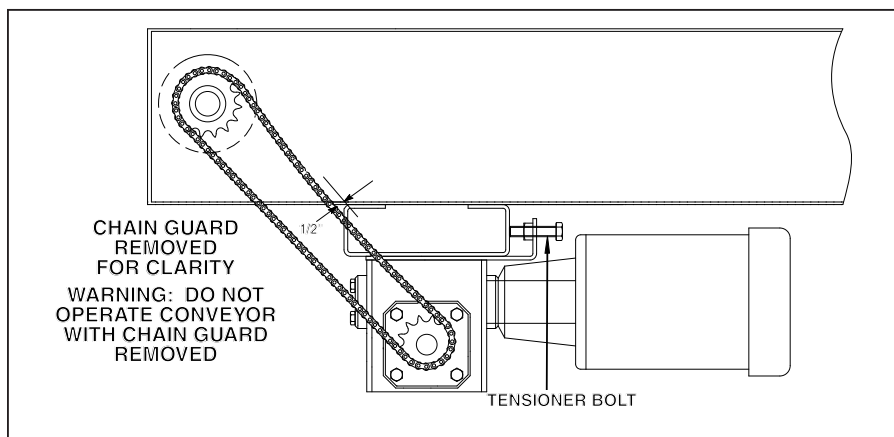

**WARNING**

Do not operate without guards in place

**WARNING**

To check drive sprocket tension, shut "OFF" and lock out power source before any adjustments are attempted.

Maintaining proper chain tension is especially important. Again, a periodic visual inspection is recommended to ensure chain tension within a pre-determined operating range.

Remember, before any adjustments are attempted, conveyor must be shut "OFF" and power source locked out.

Before replacing chain guard cover,

check to see if drive chain is operating within 1/2" range (see above illustration). If unit is out of tolerance, adjustment is necessary.

To adjust drive chain tension, tensioner bolt located on reducer push plate should be tightened (rotate clockwise) if chain tension is loose. Tighten until proper operating

range is achieved. If chain tension is too tight, loosen tensioner bolt (rotate counter-clockwise) as required. When adjustment is complete replace chain guard cover.

**WARNING:** Do not operate unit until chain guard cover is replaced. Serious operator or other personal injury could result if protective guarding is not replaced.

# START-UP PROCEDURES

## GEAR REDUCER W/ POSIVENT

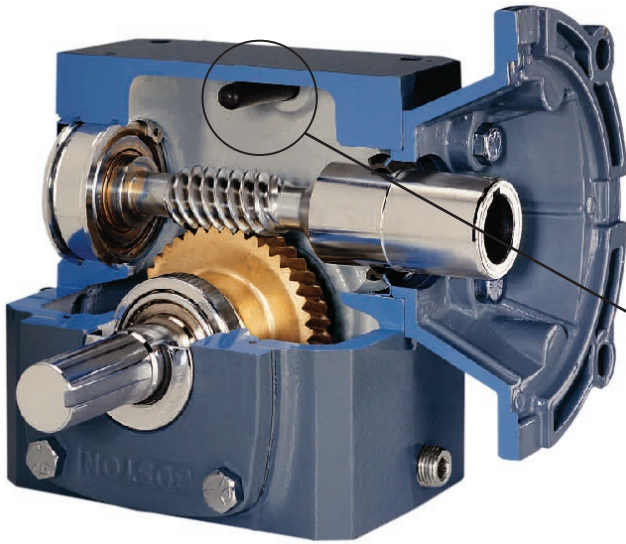

**NOTE**  
The gear reducer is supplied with a "PosiVent®". No vent plugs are required.

PosiVent Unique design incorporates a single seam construction. Factory filled with synthetic lubrication for universal mounting. Lubed for life, no oil changes are required.

To expedite the installation and start-up process, all gear reducers are shipped filled with oil. The reducers are sealed and lubed for life and require no oil changes.

## PREPARING FOR INITIAL START-UP



**⚠ DANGER**  
WARN ALL PERSONNEL TO KEEP CLEAR OF CONVEYOR DURING UNIT START-UP  
Electrical controls must be designed by a qualified electrical engineer to ensure that appropriate safety features (emergency stops, pull cords, switches, etc.) are installed on unit for safe operation. Before conveyor start-up, all operators and other personnel coming in contact with unit must be properly trained and must have read accompanying Tech Handbook.

Before conveyor start-up, all operators and other personnel coming in contact with unit must be properly trained and must have read accompanying Tech Handbook.

Provisions must be in order to instruct all personnel coming in contact with conveyor on the location of emergency stops, pull cords, etc.

A routine maintenance program should be implemented before unit is placed into operation so that fundamental unit components are attended to. This maintenance program should include an inspection to ensure that any dangerous or hazardous operating conditions are noted and IMMEDIATELY corrected, as well as including electrical and mechanical unit inspections and corrections.

Finally, when conveyor is initially started, an immediate visual inspection should include motor, gear reducer, belt tracking (discussed in following section under "Belt Tracking") and related adjustments noted in handbook for unit/component corrections.



# MAINTENANCE SAFETY PRECAUTIONS BEFORE PERFORMING MAINTENANCE

## **WARNING**

Only trained personnel shall perform maintenance functions. Before maintenance operations are performed, conveyor must be shut "OFF" and disconnects locked in the "OFF" position to prevent unit from unauthorized start-up.

One of the most important guidelines for maximizing conveyor operation and personnel safety is to implement a regular maintenance schedule and train personnel on the appropriate needs of the specific unit.

Only trained personnel shall perform maintenance functions. Before maintenance operations are performed, conveyor must be shut "OFF" and disconnects locked in the "OFF" position to prevent unit from unauthorized start-up during maintenance. All personnel should be informed of the safety procedures associated with unit maintenance and performance.

Do not perform any work on conveyors or conveyor system while in operation unless it is impossible to otherwise conduct adjustment, lubrication or other maintenance function. Only experienced, trained personnel possessing advanced hazards-training should attempt such critical operations.

## MAINTENANCE AND FOLLOW-UP DETAILS

### **WARNING**

Only trained personnel shall perform maintenance functions. When maintenance is completed, only authorized personnel shall be permitted to start conveyor following maintenance or other emergency shut-off.

While performing maintenance do not wear loose clothing. Immediately report any hazardous conditions-sharp edges, pinch (or nip) points or other conditions that may result when several manufacturers supply machinery which may create operating hazards.

When using mechanical aids such as hoists, cables, or cranes exercise extreme caution to prevent damage to conveyors or other integrated machinery which may create a working hazard when maintenance is completed and units are in operation.

Clean up any spilled lubricants or other materials used in the maintenance process or those which may be deposited during unit operation. Eliminating poor housekeeping practices increases unit efficiency while creating safer personnel working conditions.

After maintenance, conduct visual inspection to ensure that all

safety devices and guards have been replaced. Confirm that all units are clear of tools, debris or other items. Before starting conveyor, check condition of conveyor warning labels (see "WARNING LABELS" at front of handbook). If labels have been destroyed or are not clearly legible, call 870.483.7631 to receive replacement labels. Placement of warning labels is critical to avoid unauthorized unit operation which may result in hazardous working conditions for all related personnel coming in contact with conveyor.

Warn personnel that conveyor is being prepared for start-up and to stay clear of unit. Do not start conveyor until all personnel are clear. When maintenance is completed, only authorized personnel shall be permitted to start conveyor following maintenance or other emergency shut-off.

# MAINTENANCE AND LUBRICATION

## MAINTENANCE SCHEDULES

MODEL NO. \_\_\_\_\_

WEEKLY RECOMMENDED MAINTENANCE SCHEDULE*	
COMPONENT	DETAIL OF MAINTENANCE
PILLOW BLOCK / FLANGE BEARINGS	Lubricate in dirty, dusty, or moist/wet conditions
UNIT SAFETY CHECK	Confirm placement of all guards, pop-out rollers, warning labels & check for loose bolts, nip points & other hazards

MONTHLY RECOMMENDED MAINTENANCE SCHEDULE*	
COMPONENT	DETAIL OF MAINTENANCE
GEAR REDUCER	Check for leaks
SLAT CHAIN	Check for proper operation and lightly lubricate
PILLOW BLOCK / FLANGE BEARINGS	Lubricate in dirty, dusty, or moist/wet conditions
DRIVE CHAIN	Check for proper operating tension & overall wear & lubricate
DRIVE SPROCKETS	Check for overall wear & re-tighten set screws

PERIODIC RECOMMENDED MAINTENANCE SCHEDULE*	
COMPONENT	DETAIL OF MAINTENANCE
GEAR REDUCER	Check for leaks
DRIVE CHAIN	Clean (brush in solvent) & re-lubricate by applying lubricant to inside of chain with brush or spout can at 2000 hour intervals
MOTOR	Check & clear motor ventilation openings at 500 hour intervals Check miscellaneous operating conditions (normal heat & noise)

\*All charts are for guidelines in normal operating or 'as noted' conditions. Severe applications warrant additional maintenance.

# MAINTENANCE AND LUBRICATION

## GEAR REDUCER LUBRICANTS

Each gear reducer shipped from factory is originally filled with Mobil SHC 634 SYNTHETIC oil. This is the ONLY synthetic oil recommended by the gear reducer manufacturer.

In the case that the gear reducer does happen to leak oil, add oil to gear reducer through filler plug until oil comes out

oil level plug. Do not mix types and/or brands of oil. Thoroughly drain gear reducer while unit is warm prior to changing lubricant.

For operating temperatures not shown in charts below, consult factory.

SYNTHETIC GEAR REDUCER LUBRICANT			
SYNTHETIC OIL	VISCOSITY RANGE SUS @ 100°F	ISO VISCOSITY GRADE NO.	AMBIENT ROOM TEMPERATURE
Mobil SHC 634 Synthetic*	1950/2150	320/460	-30° to 225°F@ (-34° to 107°C)

\*Mobil SHC 634 Synthetic is the ONLY synthetic oil recommended by the gear reducer manufacturer.

## NON-SYNTHETIC GEAR REDUCER LUBRICANTS

RECOMMENDED NON-SYNTHETIC GEARMOTOR LUBRICANTS				
RECOMMENDED OIL	VISCOSITY RANGE SUS @ 100°F	ISO VISCOSITY GRADE NO.	AMBIENT ROOM TEMPERATURE	LUBRICANT AGMA NO.
Mobil 600W Cylinder Oil	1920/3200	460	40° to 90°F** (4.4° to 32.2°C)	7 or 7C
Mobil Extra Hecla Super Cylinder Oil	2850/3600	680	80° to 125°F** (26.7° to 51.7°C)	8 or 8C

MISC. NON-SYNTHETIC GEAR REDUCER LUBRICANTS		
MANUFACTURER	AGMA RATING NO. (7) or (7 EP)	AGMA RATING NO. (8) or (8 EP)
Getty Refining Co. Lubrication Engr. Inc.	Veedol Asreslube 95 (7 EP)	Veedol Asreslube 98 (8 EP)
	Almasol 608 (7)	Almasol 609 (8)
Shell Oil Co.	Omala 460 (7 EP) / Valvala J460 (7)	Omala 680 (8 EP) / Valvala Oil J680 (8)
Texaco Inc.	Meropa 460 (7 EP)	Meropa 680 (8 EP)



# MAINTENANCE AND LUBRICATION

## MISC. LUBRICANTS

MISC. LUBRICANTS	
General Purpose Grease (For -30°F to 300°F operation)*	Shell Dolium R (Shell Oil Co.) (or suitable equivalent)
For Extreme Temperature Operation (-90°F to 350°F operation)*	Mobiltemp SHC-32 (Mobil Oil Corp.) (or suitable equivalent)
Washdown Application* (-30°F to 225°F operation) (May require special consideration-consult factory)	Shell Alvania No. 3 (Shell Oil Co.) (or suitable equivalent)
General Purpose Oil	SAE 10; SAE 20 OR SAE 30

\*NOTE: Temperatures listed indicate the nominal operational temperature for the specific lubricant listed. This does not imply that the bearing housing, seals or any other conveyor unit component is rated to operate in this specific temperature range or environment. 250°F is the maximum operating temperature for standard bearing lubricants and bearing components. Although various lubricants may enhance bearing operation, special-order bearings may be required to achieve optimal bearing performance. For additional information, consult factory.



# TROUBLE SHOOTING AND REPLACEMENT PARTS

## TROUBLE SHOOTING / SERIAL PLATE

TROUBLE SHOOTING		
TROUBLE	PROBABLE CAUSE	REMEDY
Motor & gear reducer runs excessively hot, repeated stalling or hard to start	A. Drag on conveyor B. Lack of lubricant C. Frozen Sprocket  D. Frozen Roller E. Overload F. Electrical	A. Inspect entire conveyor for obstruction causing drag on chain. B. Check for leaks. C. Check and inspect all sprockets and bearings. Replace sprockets failing to rotate or that are difficult to rotate. D. Check all rollers for rotation. E. Reduce cause and/or increase motor horsepower. F. Check wiring and circuits, take ampere reading, replace motor if necessary.
Motor & gear reducer makes excessive noise	A. Lack of lubrication B. Damaged gears C. Faulty bearing	A. Check for leaks. B. Replace unit. C. Replace bearing.
Drive chain, conveying chain or sprockets have excessive wear	A. Excessive tension B. Sprockets misaligned C. Chain not lubricated D. Damaged sprocket or chain E. Misalignment of chain guard(s) F. Dirty chain	A. Reduce chain tension. B. Realign with straight edge across sprocket faces. C. Lubricate chain with approved lubricant, wipe away excess lube. D. Replace damaged components.  E. Adjust chain guard(s) assembly as necessary.  F. Clean thoroughly and lubricate with approved lubricant.
Drive chain, conveying chain or sprockets have excessive wear	A. Insufficient chain tension B. Chain not adequately lubricated C. Sprockets misaligned	A. Adjust chain tension. B. Lubricate chain with approved lubricant, wipe away excess lube. C. Realign sprockets with straight edge across sprocket faces.
Pulsating chain	A. Insufficient chain tension B. Misalignment of chain guard(s) C. Overload	A. Adjust chain tension. B. Adjust chain guard(s) assembly as necessary. C. Inspect for obstruction or drag on conveyor.
Broken chain	A. Frozen bearing or sprocket shaft B. Worn or damaged chain. C. Obstructed or jammed	A. Inspect for damaged bearings, replace if necessary. Replace links as required. B. Replace chain as required. C. Remove obstruction to clear jam.
Sprocket loose on shaft	A. Loose set screws B. Worn or damaged key	A. Realign sprockets with straight edge and tighten set screws B. Replace with new key.
Excessive slack in chain	A. Normal wear	A. Expect rapid chain growth in first two weeks of operation. Adjust chain tension as required.



### ORDERING REPLACEMENT PARTS

To order any replacement parts or when calling for assistance with any powered conveyor, ALWAYS provide unit serial number.

Shown at actual size, this aluminum plate is placed on the conveyor frame near the location of the drive assembly.

To order replacement parts or add-on components, contact the Roach distributor who originally furnished the unit if possible. If this is not possible, contact the National Sales Office at 870-483-7631 for the name of the authorized Roach distributor in your area. Have unit model number and serial number BEFORE calling. Refer to unit drawings (in rear section of handbook) for part numbers if ordering replacement parts.



# 608 SLAT CONVEYOR

## PARTS LIST 608 SLAT CONVEYORS

ITEM NO.	DESCRIPTION	ITEM NO.	DESCRIPTION	ITEM NO.	DESCRIPTION
1	Side Channel LH/RH	14	Take-up Sprocket	22	4-Hole Bearing w/ 2-3/16" Bore
2	Side Cover	15	Take-up Idler Sprocket	23	Take-up Brg. w/ 1-15/16" Bore
3	Bottom Chain Guard		Take-up Guide Bar	24	Slat Conveyor Chain
4	Bottom Chain Guide WS		Take-up Angle	25	3/8" Nylon Insert Lock Nut
5	Top Chain Guide Spacer		Take-up Rod		3/8"-16 UNC x 1-1/4" Flat Head
6	Top Chain Guide WS		Take-up Shaft	26	5/8"-10 UNC Hex Nut
7	Steel Slat		Take-up Spacer		5/8" Flat Washer
	Slat Spacer Plate	16	End Guard Weld Ass'y		5/8" Lock Washer
8	End Guard Mounting Angle	17	25IS Roller Assembly		5/8"-11 UNC x 2-1/4" Carriage Bolt
9	Inspection Plate	18	Motorbase Assembly	27	1-15/16" Split Locking Collars
10	2-3/16" Drive Shaft		Red. Push Plate Ass'y	28	2-3/16" Split Locking Collar
11	Take-up Shaft	19	Support Assembly	29	1/4"-20 UNV x 1" LG. Socket Head
12	Frame Crossbrace	20	Motorbase Spacer		
13	Drive Sprocket	21	Drive Kit		

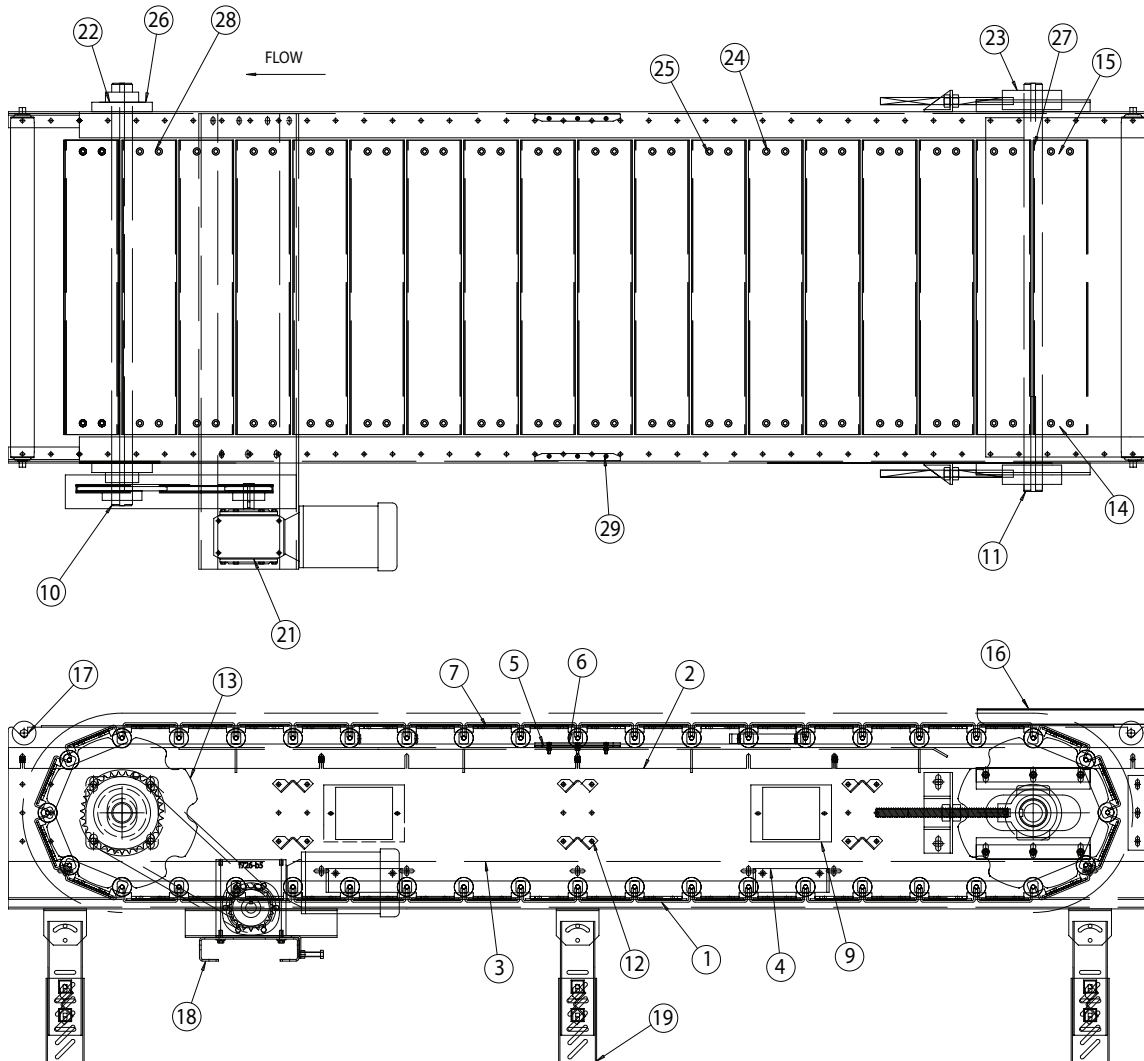





# ROACH CONVEYORS

## WARRANTY

- Materials used by Roach Conveyors are of good quality.
- Any part proving to be defective in materials or workmanship upon Roach inspection, will be replaced at NO cost, FOB, Trumann, Arkansas, for one year. Installation expense will be paid by others.
- Roach liability includes furnishing said part or parts; Roach is not liable for consequential damages, such as loss of profit, delays or expenses incurred by failure of said part or parts.
- Failure due to abuse, incorrect adjustments, exposure to corrosive or abrasive environment or operation under damp conditions does not constitute failure due to defects in workmanship or materials.
- Component parts not manufactured by Roach (motors, gear reducers, etc.) will be repaired or replaced at the option of their manufacturer. Contact nearest authorized service center for all warranty claims.

NOTE: Motors or gear reducers tampered with before inspection shall be considered free of ALL Warranty Claims.

--All specifications are subject to change without notice--  
--Drawings are intended for illustration ONLY and are not to scale--

ROACH CONVEYORS  
808 HIGHWAY 463 NORTH  
TRUMANN, ARKANSAS 72472-1310  
Tel 870-483-7631 Fax 870-483-7049  
[info@roachconveyors.com](mailto:info@roachconveyors.com)  
[www.roachconveyors.com](http://www.roachconveyors.com)