

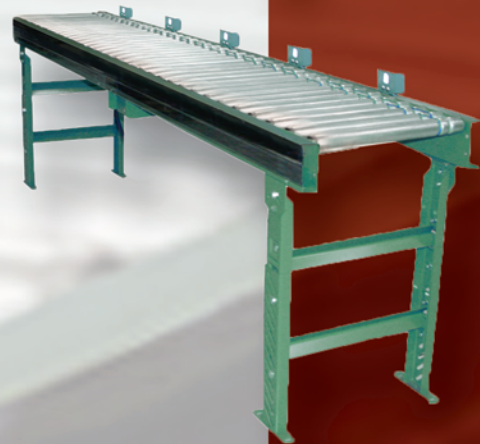

OWNER'S MANUAL

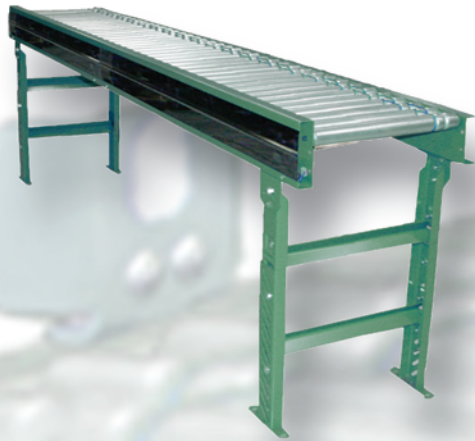

Powered Roller Accumulator

Model 796PRA • 596PRA • 796PRAC
596PRAC • 796PRA-PV • 596PRA-PV

DO NOT OPERATE BEFORE READING THIS HANDBOOK
KEEP IN A SAFE PLACE – DO NOT DISCARD

TECH HANDBOOK FOR POWERED ROLLER CONVEYORS

TABLE OF CONTENTS

POWERED ROLLER CONVEYOR TECH HANDBOOK	2	PARTS LISTS FOR POWERED ROLLER CONVEYORS	14
-Caution Labels	2	-Parts List for 796 PRA.....	14
CAUTIONS, WARNINGS AND HAZARDS	3	-Parts Drawing for 796 PRA.....	15
-Introduction.....	3	-Parts List for 796 PRAC	16
-Cautions, Warnings and Hazards.....	3	-Parts Drawing for 796 PRAC	17
SAFETY INFORMATION, ABOUT POWERED ROLLER CONV.	4	-Parts List for 596 PRA w/ Retroflective Photoeye	18
-Important Safety Guidelines.....	4	-Parts Drawing for 596 PRA w/ Retroflective Photoeye	19
-About Powered Roller Conveyor.....	4	-Parts List for 596 PRAC w/ Retroflective Photoeye.....	20
RECEIVING AND INSPECTION	5	-Parts Drawing for 596 PRAC w/ Retroflective Photoeye.....	21
-Shortages, Damages and Return Authorizations	5	-Parts List for 596 PRA w/ Diffuse Photoeye.....	22
-Uncrating.....	5	-Parts Drawing for 596 PRAw/ Diffuse Photoeye	23
GENERAL INSTALLATION INFORMATION	6	-Parts List for 596 PRAC w/ Diffuse Photoeye	24
-Identifying / Installing Permanent Floor Supports	6	-Parts Drawing for 596 PRAC w/ Diffuse Photoeye	25
-Installation of Polytier Supports	6	-Parts List for 796 PRA-PV.....	26
-Installing Knee braces and Casters.....	7	-Parts Drawing for 796 PRA-PV	27
-Installation of Ceiling Hangers.....	7	-Parts List for 596 PRA-PV.....	28
MAINTENANCE SAFETY PRECAUTIONS	8	-Parts Drawing for 596 PRA-PV	29
-Before Performing Maintenance	8	Notes	30
-Report On Miscellaneous Maintenance Performed	9	WARRANTY	31
TECHNICAL	10		
-Powered Roller	10		
-Connecting Bed Sections.....	10		
-Drive Card Connections and Settings.....	11		
-Zero Pressure Accumulation	12		
-Speed and Technical Data	13		

CAUTION LABELS



ABOVE: Label attached to all protective guards (drives, spool guards, etc.)

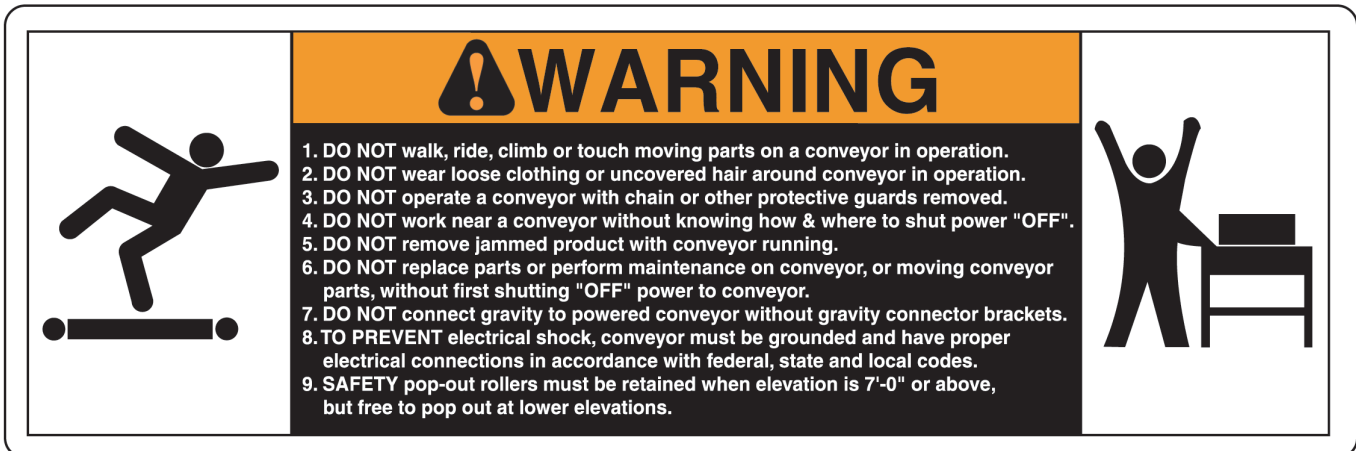

ABOVE: Label placed near all drive assemblies and at 30' intervals

CAUTIONS, WARNINGS AND HAZARDS INTRODUCTION

This manual was prepared as a “how-to-guide” for installers, end-users and maintenance personnel. It is also intended to educate both owner (purchaser) and all individuals working around the unit, of potential hazards.

With proper installation and maintenance, conveyors are essential for achieving a variety of functions essential in today’s industrial marketplace. By following a simple, periodic maintenance schedule, the life of a typical conveyor (or, most any type of machinery--including our automobiles!) will increase when compared to a similar

unit in an application receiving little or no maintenance. You may find that a conveyor can become your best workplace friend by following simple safety guidelines.

Failure to follow even the most basic safety suggestions can result in serious personal injury.

Conveyors contain many moving parts--pulleys, belting, chains, sprockets, shafts, rollers, etc. Therefore, it is imperative to become familiar with basic unit operation and know all points of potential hazards.

Remember, when working around or near conveyors (and **any** industrial machinery)

it is **your** responsibility to become familiar with the unit, to know potential hazards (many are noted with caution labels) and to operate unit in strict accordance with the safety guidelines in this manual.

Keep this manual in a safe place for future reference. It should be placed where appropriate personnel may maintain proper maintenance and records.











This manual must be read by all new users before operating or working near this unit.

 **WARNING**

DO NOT OPERATE BEFORE READING THIS MANUAL!
KEEP IN SAFE PLACE--DO NOT DISCARD!

CAUTIONS, WARNINGS AND HAZARDS

 **WARNING**

-  NEVER connect belt conveyors directly to gravity conveyors, machinery or fixtures without using connector brackets & pop out roller.
-  ALWAYS anchor permanent supports to floor (or mounting surface). Use 3/8" x 2-1/2" (or longer) wedge anchors for permanent installation in concrete flooring.
-  It is the responsibility of the customer and installation personnel to supply and install net or mesh guarding on overhead mounted conveyors to prevent product and/or debris from falling to floor in areas where required.
-  If belt conveyor pulleys are adjusted during installation or maintenance, nip point guard (at drive end on end drive unit) must be readjusted. Nip point guard (take-up end) is automatically adjusted when take-up pulley is adjusted. Nip point guards at both ends of conveyor (center drive) must be readjusted. Center drive guards **MUST** be replaced after installation or maintenance.
-  Before unit is ready for operation, snub roller guard (cover) must be adjusted to ensure safe unit operation.
-  Belt lacing must be kept in good condition for safe work environment.
-  source before attempting any adjustments.
-  To check drive sprocket tension, shut “OFF” and lock out power source before any adjustments are attempted.
-  Electrical controls must be designed by a qualified electrical engineer to ensure that appropriate safety features (emergency stops, pull cords, switches, etc.) are installed on unit for safe operation. Before conveyor start-up, all operators and other personnel coming in contact with unit must be properly trained and must have read accompanying Tech Handbook.
-  Upon start-up, if belt tracks to one side, turn unit “OFF”, lock out power source and confirm that conveyor is square and that all prime tracking components are square with bed. Belt tracking adjustments should be performed by trained personnel **ONLY**. Read section on “Belt Tracking” completely before attempting belt tracking adjustments.
-  Only trained personnel shall perform maintenance functions. Before maintenance operations are performed, shut conveyor “OFF” and lock out power source to prevent unauthorized start-up. When maintenance is completed, only authorized personnel shall be permitted to start conveyor following maintenance or other emergency shut-off.

WARNING

WARNING: All personnel coming in contact with this conveyor should be aware of the following safety guidelines **BEFORE USING OR WORKING AROUND CONVEYOR**. **NOTE:** ALWAYS notify Roach Manufacturing® whenever any conveyor is used in an application or condition other than was originally intended. Failure to notify Roach® may allow conveyor to be operated in a hazardous operating condition. Injuries resulting from negligence or violation of safety instructions hereby removes responsibility of product liability claims from Roach®.

 Do not operate conveyor with protective guards removed. This includes chain guards, belt guards, snub roller guards, center drive guards and any other safety guard.

 Do not replace parts or perform maintenance on conveyor, or moving conveyor parts, without first shutting "OFF" power to conveyor and locking out power source.

pop out when conveyors are installed at or below 7'-0" elevation.

 It is the responsibility of conveyor end-user to comply with all safety standards including OSHA and other federal, state, and local codes or regulations. Install protective guarding and other related safety precautionary equipment to eliminate hazardous operating conditions which may exist when two or more vendors supply machinery for related use.

 Do not walk, ride, climb, or touch moving parts on a conveyor in operation.

 Do not connect gravity to powered conveyor without safety gravity connector brackets.

 Do not wear loose clothing or uncovered hair around conveyor.

 To prevent electrical shock, conveyor must be grounded, and have proper electrical connections in accordance with federal, state, and local codes.

 Do not work near conveyor without knowing how & where to shut power "OFF" and lock out power source.

 Safety pop out rollers in conveyors installed above 7'-0" elevation must be retained by guard rail, clips, etc. Safety pop out rollers must be allowed to

 Any violation of above safety instructions hereby removes all product liability claims from Roach Manufacturing Corporation®.

ABOUT POWERED ROLLER CONVEYOR

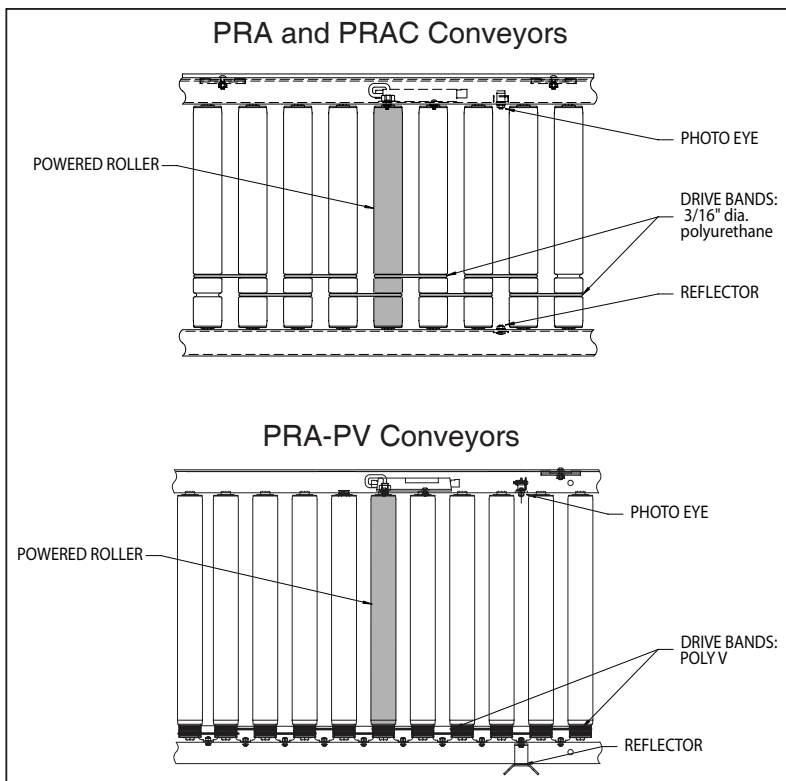

Each zone of the Powered Roller Conveyors are driven by a 24 VDC powered roller. The motor is contained inside a 1.9" roller which turns the roller.

The rollers in each zone of the PRA and PRAC conveyors are connected with 3/16" Polyurethane drive belts and PRA-PV conveyors are connected with either a 2 or 3 rib Poly-V belt. These accumulation zones are controlled with a photo eye.

RECEIVING AND INSPECTION SHORTAGES, DAMAGES AND RETURN AUTHORIZATIONS

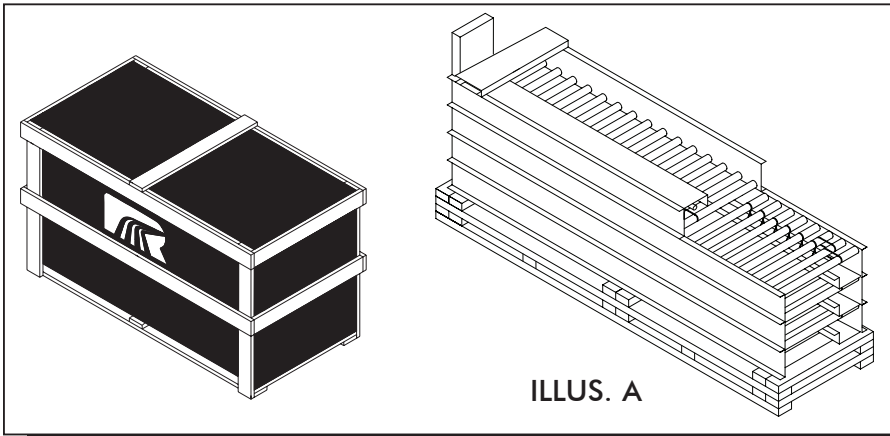

NOTE: Do not return goods to factory without prior, written return authorization. Unauthorized returns are subject to refusal at factory.

Before uncrating, check the quantity of items received against bill of lading to confirm that all material has been received. Examine the condition of the equipment to determine if any damage has occurred.

Also, it is possible that some items may become separated from the original shipment. Therefore, when receiving goods, it is imperative that the bill of lading (or,

accompanying freight documentation) be checked to ensure receipt of ALL units ordered including ALL accessories.

Damage and/or shortage in shipment should be reported immediately to both vendor and carrier. Obtain a signed damage report from carrier agent and send copy to vendor. **Do not repair any damage before obtaining this report.**

For damaged shipments, consult factory to determine if entire shipment must be returned to factory for repair **or** if an immediate order should enter production to produce a new, replacement shipment.

UNCRATING

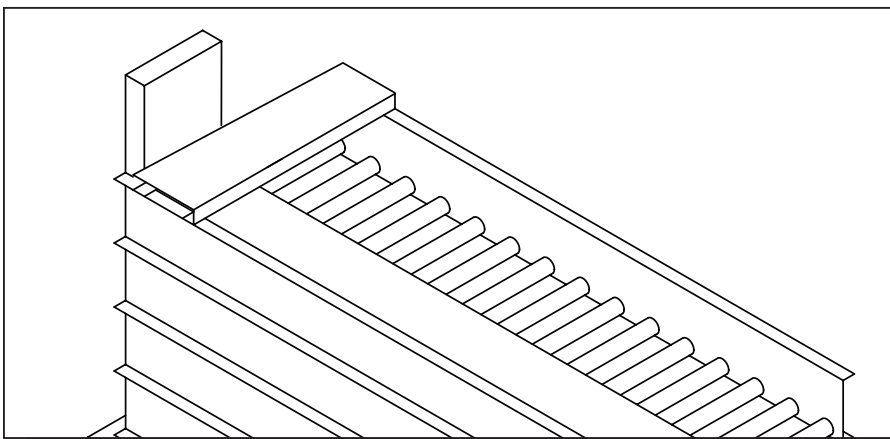

NOTE: Carefully examine shipment during uncrating to ensure that essential components are not discarded. This includes guard rail and other necessary hardware.

After receipt and initial inspection is completed, carefully remove crating and look for essential components and specific accessories that may have been boxed and attached (or 'banded') to crating material. Guard rails and hardware are often pack-

aged and shipped in this manner. Save all hardware for subsequent use by installation personnel.

The drive section will be shipped mounted to its actual operating bed section (see illustration above).

Some items (electric motors, gearbox, etc.) may be shipped direct from their manufacturer to final destination. Thus, the conveyor may consist of two or more separate shipments.

GENERAL INSTALLATION INFORMATION

IDENTIFYING/INSTALLING PERMANENT FLOOR SUPPORTS

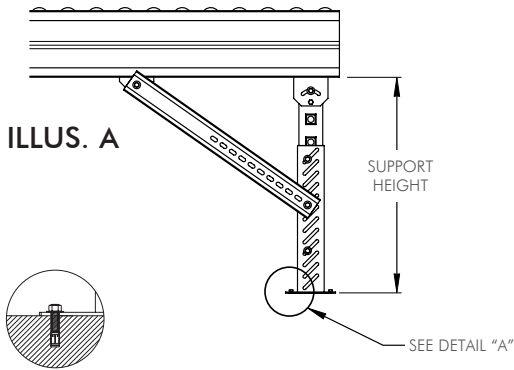

ILLUS. A

Detail "A"

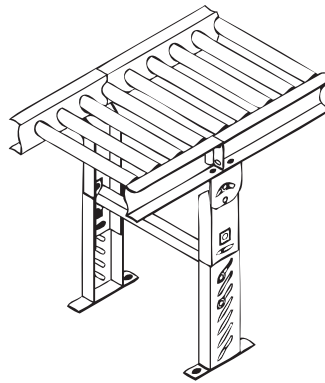

ILLUS. B

⚠ WARNING

Always anchor permanent supports to floor (or mounting surface). Use 3/8" x 2-1/2" (or longer) wedge anchors for permanent installation in concrete flooring.

*MINIMUM/MAXIMUM SUPPORT HEIGHT			
SM-1	7-1/4" — 10-1/4"	SM-7	34-1/4" — 46-1/4"
SM-2	10-1/4" — 13-1/4"	SM-8	46-1/4" — 58-1/4"
SM-3	13-1/4" — 16-1/4"	SM-9	58-1/4" — 70-1/4"
SM-4	16-1/4" — 22-1/4"	SM-10	70-1/4" — 82-1/4"
SM-5	20-1/4" — 26-1/4"	SM-11	80-1/4" — 92-1/4"
SM-6	24-1/4" — 36-1/4"	SM-12	92-1/4" — 104-1/4"

Permanent supports may be installed on conveyors at various locations. However, it is most common to use single tier permanent floor supports at each end of a powered section (see illustration A above) and where intermediate bed sections are adjoined (see illustration B above). Notice intermediate supports have two lag bolts in a diagonal pattern while end (terminal) supports have four lag bolts, one in each of

the four foot plate mounting holes.

When two (or more) powered conveyors are placed end-to-end, a single tier permanent support may be used at the end junction commonly supporting both units. Check load rating of support before using this method of installation.

Adjust elevation to top of conveyor by loosening bolts in support uprights, raising

or lowering conveyor and fully tightening bolts at desired elevation. Tighten all bolts in supports **before** unit operation. Complete support installation by lagging support attachment plates to floor. Confirm that unit is level across width of conveyor before completing final support height adj.

*Supports are normally shipped at minimum support height. See chart above.

INSTALLATION OF POLYTIER SUPPORTS

MIN. ELEVATION = 11" ELEV.
(3-1/2" + FRAME)

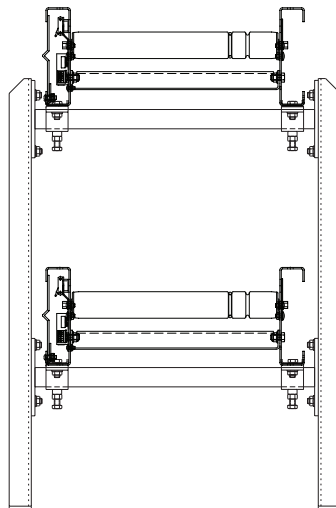

Polytier supports provide convenient installation method for two or more tiers of conveyor. To install, raise conveyor to desired elevation (approximate). Place 1" inside diameter cross pipe underneath lower conveyor flange. Attach cross pipe to upright legs. Use U-shaped retainer ("hat")

bracket with coupling plate to connect cross pipe to conveyor flange. Do not tighten fully at this time.

Standard elevation style attachment brackets offer unit elevation of 3-1/2" + frame and includes bracket welded to cross pipe which is bolted to upright legs during instal-

NOTE: To install, raise conveyor to desired elevation, place cross pipe underneath frame, attach cross pipe to upright legs and use U-shaped retainer ("hat") bracket to connect cross pipe to lower conveyor flange.

POLYTIER SUPPORT CHANNEL HEIGHT					
PSM-1	23"	PSM-6	53"	PSM-11	83"
PSM-2	29"	PSM-7	59"	PSM-12	89"
PSM-3	35"	PSM-8	65"	PSM-13	95"
PSM-4	41"	PSM-9	71"	PSM-14	101"
PSM-5	47"	PSM-10	77"	PSM-15	107"

lation.

When unit is at operating elevation and unit has been checked across width for level, tighten locking bolts in U-shaped bracket. Add knee braces for unit rigidity.

GENERAL INSTALLATION INFORMATION

INSTALLING KNEE BRACES AND CASTERS

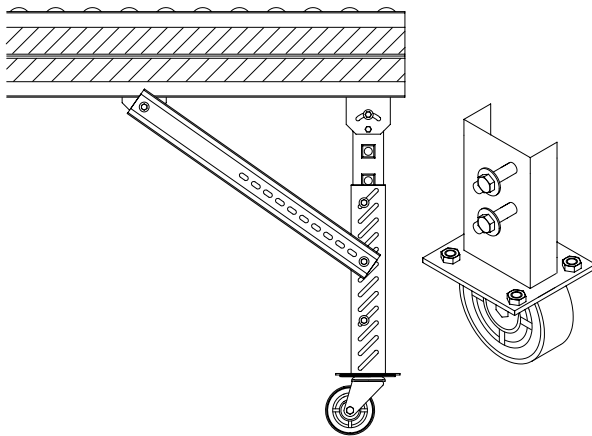

NOTE: Install knee brace (when supplied) after final permanent support installation and elevation adjustment.

Knee braces add strength to permanent supports and stability to units in portable applications. Install knee brace (when supplied) after final permanent support installation and elevation adjustment. Its pivot bracket is bolted to underneath side of lower conveyor flange and slotted end is attached to outer side of support.

Castors (when supplied) are generally installed at the factory. However, when receiving casters direct from their supplier, final attachment to support is necessary. A special slotted pre-punched caster attachment plate is supplied on supports designed for casters.

A standard support is not designed for attachment to casters. Field modification or replacement of outside support assemblies is required.

INSTALLATION OF CEILING HANGERS

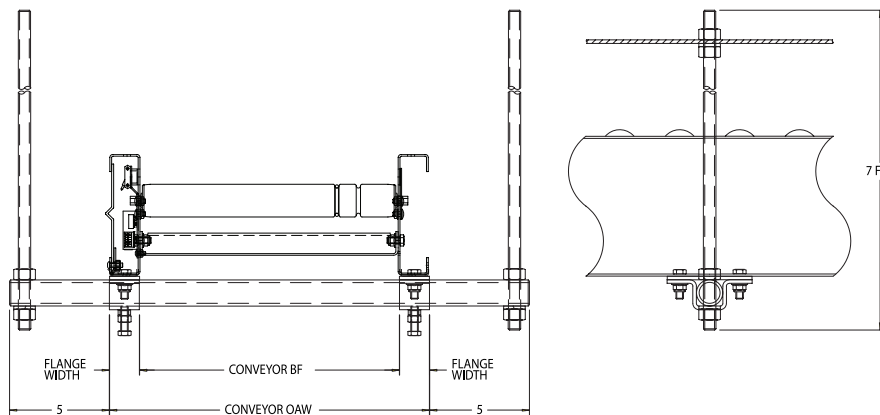

⚠ WARNING

It is the responsibility of the customer and installation personnel to supply and install net or mesh guarding on conveyors mounted overhead to prevent product and/or debris from falling to floor in areas where required.

Ceiling hangers are frequently used in high-elevation applications for suspension from ceiling. The 5/8" diameter (#11 UNC) all threaded rod is supplied to allow infinite vertical adjustment along the length of the suspension rod (see illustration above).

Attach and firmly tighten U-shaped retainer ("hat") bracket with coupling plate to underneath side of frame with hardware

provided to hold cross pipe (1" inside diameter) against underneath side of conveyor.

Do not tighten cross pipe locking bolts (these attach in the bottom of the U-shaped retainer bracket) until threaded suspension rods have been firmly secured to ceiling structure.

To adjust conveyor elevation, tighten or

loosen lower nut and jam nut on threaded suspension rods to desired elevation. A lock washer must be used on suspension rods to maintain unit at desired elevation.

When unit is at operating elevation and unit has been levelled across bed width, tighten locking bolts in U-shaped bracket to secure position of cross pipe.

MAINTENANCE SAFETY PRECAUTIONS BEFORE PERFORMING MAINTENANCE

WARNING

Only trained personnel shall perform maintenance functions. Before maintenance operations are performed, conveyor must be shut "OFF" and disconnects locked in the "OFF" position to prevent unit from unauthorized start-up.

One of the most important guidelines for maximizing conveyor operation and personnel safety is to implement a regular maintenance schedule and train personnel on the appropriate needs of the specific unit.

Only trained personnel shall perform maintenance functions. Before maintenance operations are performed, conveyor must be shut "OFF" and disconnects locked in the "OFF" position to prevent unit from unauthorized start-up during maintenance. All personnel should be informed of the safety procedures associated with unit maintenance and performance.

Do not perform any work on conveyors or conveyor system while in operation unless it is impossible to otherwise conduct adjustment, lubrication or other maintenance function. Only experienced, trained personnel possessing advanced hazards-training should attempt such critical operations.

MAINTENANCE AND FOLLOW-UP DETAILS

WARNING

Only trained personnel shall perform maintenance functions. When maintenance is completed, only authorized personnel shall be permitted to start conveyor following maintenance or other emergency shut-off.

While performing maintenance do not wear loose clothing. Immediately report any hazardous conditions--sharp edges, pinch (or nip) points or other conditions that may result when several manufacturers supply machinery which may create operating hazards.

When using mechanical aids such as hoists, cables, or cranes exercise extreme caution to prevent damage to conveyors or other integrated machinery which may create a working hazard when maintenance is completed and units are in operation.

Clean up any spilled lubricants or other materials used in the maintenance process or those which may be deposited during unit operation. Eliminating poor housekeeping practices increases unit efficiency while creating safer personnel working conditions.

After maintenance, conduct visual inspection to ensure that all safety devices and guards have been replaced. Confirm that all units are clear of tools, debris or other items. Before starting conveyor, check condition of unit caution labels (see "CAUTION LABELS" at front of handbook). If labels have been destroyed or are not clearly legible, call 870.483.7631 to receive replacement labels. Placement of caution labels is critical to avoid unauthorized unit operation which may result in hazardous working conditions for all related personnel coming in contact with conveyor.

Warn personnel that conveyor is being prepared for start-up and to stay clear of unit. Do not start conveyor until all personnel are clear. When maintenance is completed, only authorized personnel shall be permitted to start conveyor following maintenance or other emergency shut-off.

The Roller drive is a completely self-contained electronically powered roller. The internal 24 VDC motor drives the roller and guarantees a constant speed over a wide load range and a constant torque over most of the selectable speed settings.

EC100 COMPONENTS

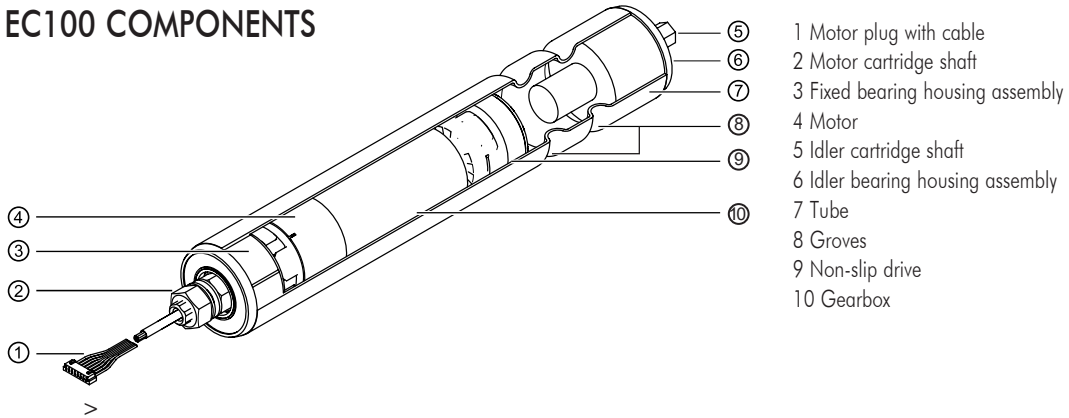

EC110 COMPONENTS

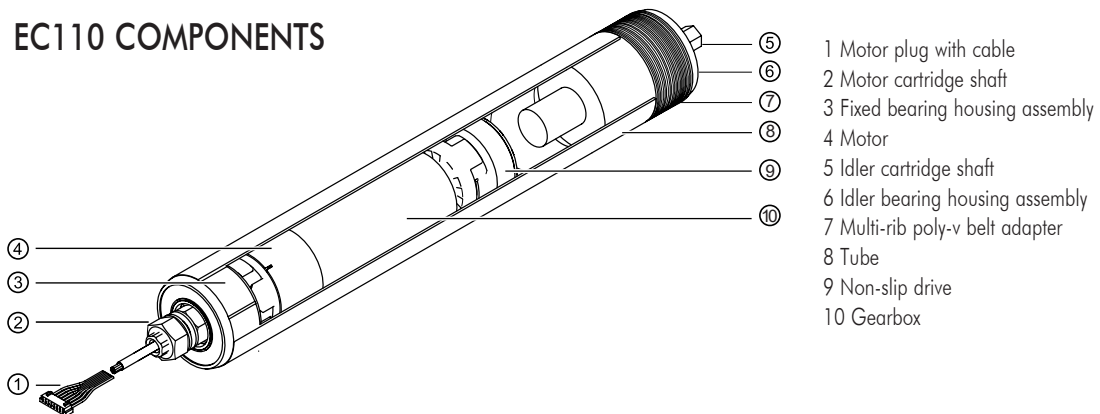

CONNECTING BED SECTIONS

To connect bed sections locate the WAGO connectors shown in illustration A and the coordinating wires on the next bed section shown in illustration B.

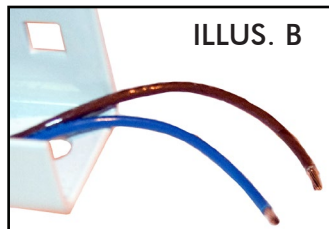
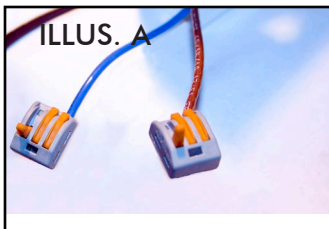

Match wire colors and connect as demonstrated below.

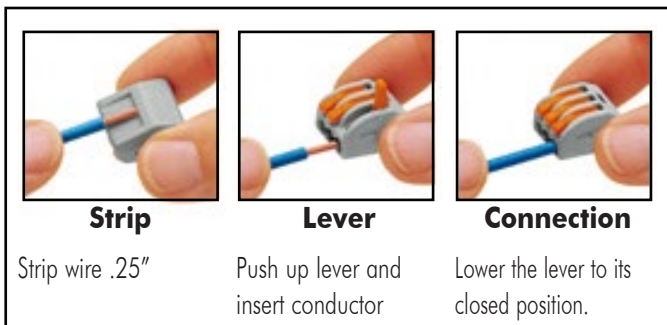

Next locate the peer-to-peer cable shown in illustration C and connect it to the first card in the next bed section in the modular connector shown in illustration D.

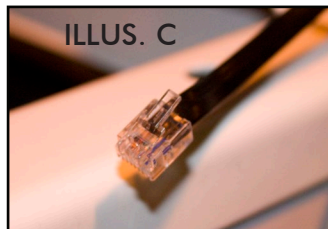

All power to conveyor should be off when making connections.



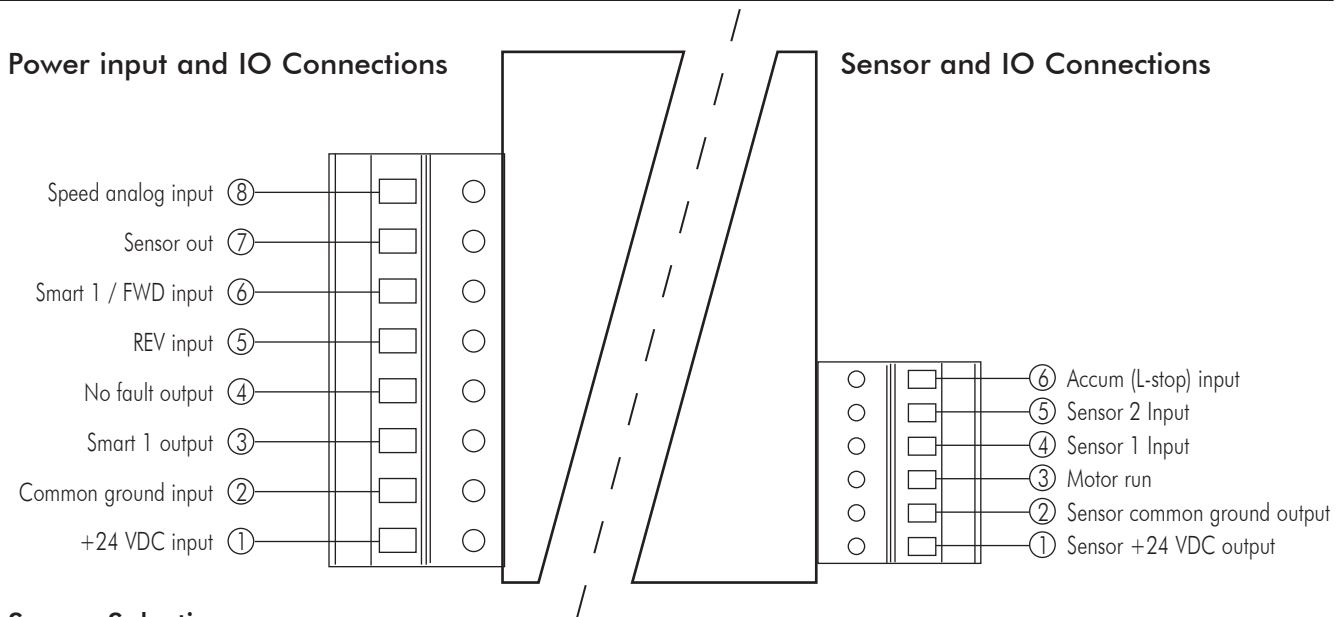

Sensor Selection

Only the sensors mentioned below may be chosen: (sensor supply current from the board is 50mA max)

- NPN retro reflectie (reflector required) - dark operate, normally closed (NC) contact.
- NPN diffused (no reflector) - light operate, normally open (NO) contact
- PNP retro reflectie (reflector required) - dark operate, normally closed (NC) contact
- PNP diffused (no reflector) - light operate, normally open (NO) contact

Dip Switch Operation

	EC100		EC110	
	ON	OFF	ON	OFF
SW7: Roller Drive Section	----	OFF	ON	-----
SW6: Roller Drive Section	----	OFF	-----	OFF
SW5: Downstream	Jog/Rev ON	Standard	Jog/Rev ON	Standard
SW4: Upstream	Jog/Rev ON	Standard	Jog/Rev ON	Standard
SW3: Singulation	Enhanced	Standard	Enhanced	Standard
SW2: Rotation	CW	CCW	CW	CCW
SW1: Logic	PNP	NPN	PNP	NPN

Learn Mode Reset

At startup “Learn Mode” automatically sets the zone length, and saves it, simply by running an object from the upstream sensor to the downstream sensor. If the sensor positioning or zone length should change after startup, you must reset the learn mode. Simply remove the two screws from the cover to reveal the two pin header shown below. Carefully short these two pins together until you see the LED’s flash. Immediately remove the short. You are now ready to run an object from the upstream sensor to the downstream sensor to “re-learn” the zone length.

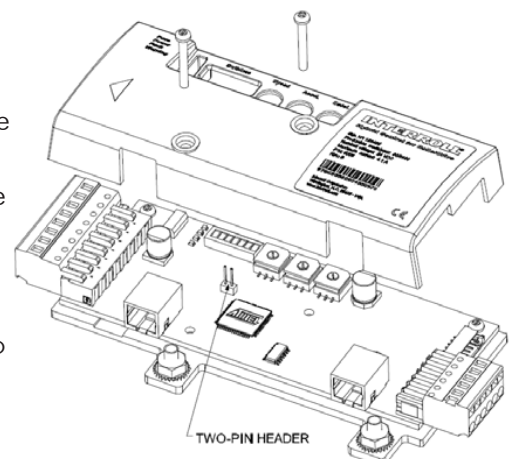

ZPA is short for zero pressure accumulation. The DriveControl provides true zero pressure accumulation and other control options to a conveyor system. Each DriveControl controls a RollerDrive unit, which in turn drives idler rollers using O-rings or other belts. The DriveControl, the RollerDrive, and the idler rollers (with associated sensors and switches) are assembled into a short conveyor section – a zone.

Zero pressure accumulation occurs as zones hold packages until the next downstream zone clears its sensor. When accumulation occurs, a

low signal is passed upstream until each consecutive zone is occupied. Packages never push each other, and no line pressure occurs.

A logic-controlled, zero pressure conveyor is created when a number of zones are connected together and a simple six-wire phone cable links each DriveControl electronically. The RollerDrives only operate when a package is detected by a photoeye. If the downstream zone is empty, the package moves forward.

Principle of zones

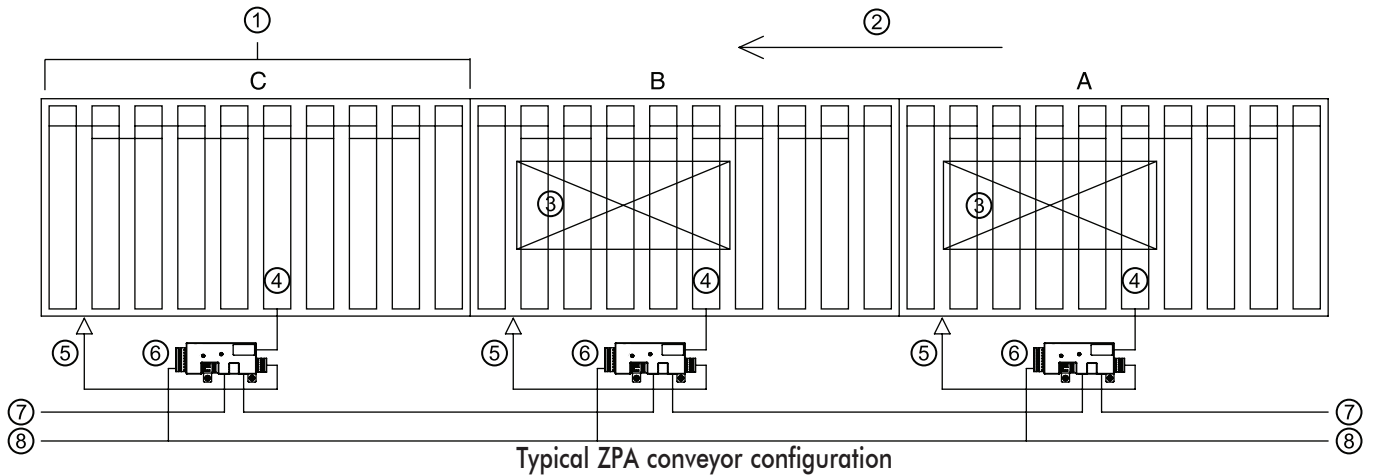

Typical ZPA conveyor configuration

- 1 Zone
- 2 Direction of travel
- 3 Load
- 4 RollerDrive
- 5 Photoeye
- 6 HC-DriveControl
- 7 Peer-to-peer communication cable
- 8 +24 VDC / GND

Zone A has a package at the photoeye. The DriveControl of zone A recognizes its presence, checks zone B for availability and requests permission to transfer the package to zone B. Since zone B has also a package, its DriveControl denies the permission until this package has been transferred to zone C (singulation mode), or has at least started

being transferred (enhanced singulation mode). The singulation method depends on the setting of DIP switch SW3.

The HC-Drive Control of zone A will only start to operate the rollerDrives in its zone after it gets permission from the DriveControl of zone B.

Typical ZPA configuration with Entry and Exit Zones

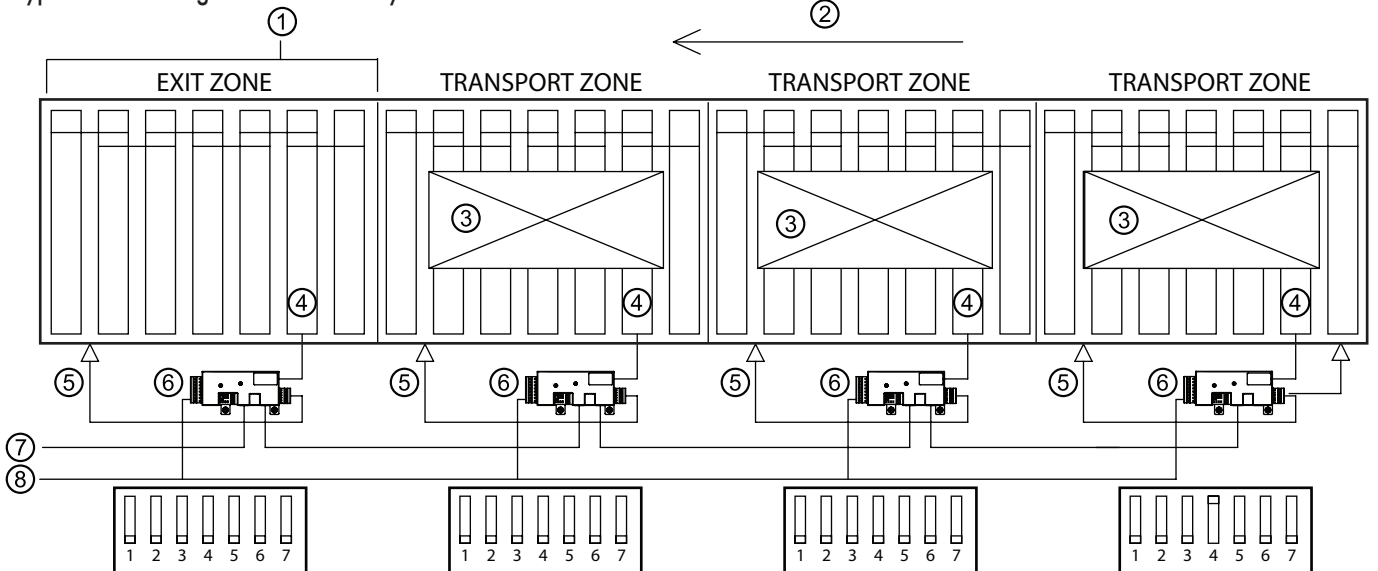

Speed Specifications for Roller Drives

The speed can be continuously adjusted (between 100% and 33% for the EC100 and EC110 powered rollers) by the rotary switch marked "speed" on the DriveControl. The type of Roller Drive is indicated at #7. Default setting is maximum. Roller Drive ratio can be found on the label at the end of the roller. #3 indicates where the ratio is specified.

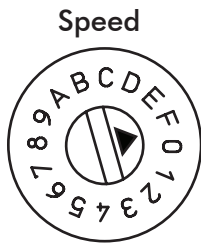

Speed

Label on the Roller Drive

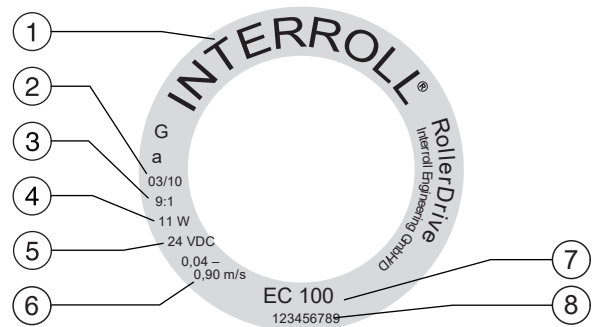

Type plate

- 1 Manufacturer
- 2 Date of production
- 3 Gear ratio
- 4 Performance
- 5 Nominal voltage
- 6 Speed range
- 7 Type of Roller Drive
- 8 Serial number

Speeds (FPM) per speed switch position setting and gear ratio

POS	% of FULL	GEAR RATIO EC100						
		12:1	16:1	24:1	36:1	48:1	64:1	96:1
F	100	260	202	135	88	68	50	34
E	96	250	194	130	85	65	48	33
D	91	237	184	123	80	62	46	31
C	87	226	176	118	77	59	44	30
B	82	213	166	111	72	56	41	28
A	78	203	158	105	69	53	39	27
9	73	190	148	99	64	50	37	25
8	69	179	139	93	61	47	35	24
7	64	166	129	86	56	44	32	22
6	60	156	121	81	53	41	30	20
5	55	143	111	74	48	37	28	19
4	51	133	103	69	45	35	26	17
3	46	120	93	62	41	31	23	16
2	42	109	85	57	37	29	21	14
1	38	99	77	51	33	26	19	13
0	33	86	67	45	29	22	16	11

POS	% of FULL	GEAR RATIO EC110							
		4:1	9:1	12:1	16:1	24:1	36:1	48:1	64:1
F	100	475	211	158	119	79	53	40	30
E	96	456	203	152	114	76	51	38	29
D	91	432	192	144	108	72	48	36	27
C	87	413	184	138	104	69	46	35	26
B	82	390	173	130	98	65	44	33	25
A	78	371	165	123	93	62	41	31	23
9	73	347	154	115	87	58	39	29	22
8	69	328	146	109	82	55	37	28	21
7	64	304	135	101	76	51	34	26	19
6	60	285	127	95	71	47	32	24	18
5	55	261	116	87	66	43	29	22	17
4	51	242	108	81	61	40	27	20	15
3	46	219	97	73	55	36	24	18	14
2	42	200	89	66	50	33	22	17	13
1	38	181	80	60	45	30	20	15	11
0	33	157	70	52	39	26	17	13	10

9006 Technical Data

Nominal voltage	24VDC
Voltage range	22 to 26 VDC
Voltage ripple tolerance	<5%, <1% recommended
Continuous current	EC100: 1.8A EC110: 2.4A
Peak Current	EC100: 4.1A EC110: 5.1A
Fuse	5 A slow blow Littelfuse 0452005
Protection classification	IP20

Ambient temperature	0°C to 40°C
for operation	(32°F to 104°F)
Ambient temperature for transport and storage	-20°C to 75°C (-4°F to 167°F)
Ambient temperature changes	max. 1°K/min; 3 h: two cycles according to IEC 68-2-14
Ambient Humidity	max. 90% not condensing
Installation altitude above sea level	max. 1000m (max. 3300 ft)

PARTS LIST FOR POWERED ROLLER CONVEYORS 796 PRA W/ RETROREFLECTIVE PHOTOEYES

ITEM	DESCRIPTION	PART #
1	196G DOUBLE GROOVED ROLLER ASSEMBLY	196G-BF-E-D2438
2	PHOTOEYE ZONE CONTROL KIT	A29664
3	NT16048CB BLACK CABLE TIE 6.30" LG.	ELW08412-03
4	#567 SCOTCHLOK TAP CONNECTOR	ELW08451
5	ZL2-F2415 1045389 RETROREFLECTIVE PHOTOEYE	ELW08590
6	#18 TFFN BROWN WIRE (TAP FROM CARD TO MAINLINE)	ELW08947
7	#18 TFFN BLUE WIRE (TAP FROM CARD TO MAINLINE)	ELW08948
8	#6-32 X 1" RHSMS	FSW02049
9	#10-24 X 1/2" IHWHMS	FSW02054
10	#6 LOCKWASHER	FSW08476
11	#6 FLAT WASHER	FSW08476-01
12	#6-32 HEX NUT	FSW08477
13	#10-24 NYLON INSERT LOCK NUT	FSW09002
14	PHOTOEYE MOUNTING BRACKET	M09256
15	REFLECTOR TAPE MOUNT	M09258
16	BRT-THG-1-100-BAN 1" WIDE REFLECTOR TAPE	MCW06306-01
17	EC9006 CONTROL CARD WITH HARDWARE	PRW06810
18	222-413 WAGO WIRE CONNECTOR	ELW08450
19	24" LG. COMMUNICATION CABLE ASSEMBLY (18" ZONE)	ELW08503-24
	30" LG. COMMUNICATION CABLE ASSEMBLY (24" ZONE)	ELW08503-30
	36" LG. COMMUNICATION CABLE ASSEMBLY (30" ZONE)	ELW08503-36
20	#12 THHN BROWN WIRE (MAINLINE POWER)	ELW08933
21	#12 THHN BLUE WIRE (MAINLINE POWER)	ELW08946
22	3/8"-16 X 3/4" HHCS	FSW00355
23	3/8"-16 X 3/4" CARRIAGE BOLT	FSW04355
24	1/4"-20 X 3/4" PHPMS	FSW08481
25	1/4"-20 CAGE NUT	FSW09099
26	3/8"-16 NYLON INSERT FLANGE NUT	FSW09304-02
27	FRAME CROSSBRACE	M00119-BF
28	COVER MOUNTING CLAMP	M09199
29	SPLICE PLATE	M09200
30	CONTROLS SIDE CHANNEL	M09204-RC-ZL-LG
31	TRANSPARENT COVER FOR CONTROLS	M09205-LG
32	BELT SIDE CHANNEL	M09259-RC-ZL-LG
33	EC100 1.9 OD 24V DOUBLE GROOVED POWERED ROLLER	PB-1505
34	3/16" DIA. X 9 1/2" LG. DURA-BELT BLUE HT 85A	VBW71386

ORDERING REPLACEMENT PARTS



ROACH CONVEYORS
 808 HIGHWAY 463
 TRUMANN, AR 72472
 TEL 870-483-7631

SERIAL NO. 123456

To order any replacement parts or when calling for assistance with any powered roller conveyor, **ALWAYS** provide the unit serial number. Shown at left, this is placed on the conveyor frame opposite the control side and is typically near the center.

To order replacement parts or add-on components, contact the Roach distributor who originally furnished the unit if possible. If this is not possible, contact the

National Sales Office at 870-483-7631 for the name of the authorized Roach distributor in your area. Have unit model number and serial number **BEFORE** calling. Refer to unit drawings in this handbook for part numbers if ordering replacement parts.

PARTS LIST FOR POWERED ROLLER CONVEYORS 796 PRA W/ RETROREFLECTIVE PHOTOEYES

REFERENCE POINT FOR HAND OF CONTROLS IS TAKEN FROM INFEEED END OF CONVEYOR.

LEFT HAND CONTROLS



RIGHT HAND CONTROLS

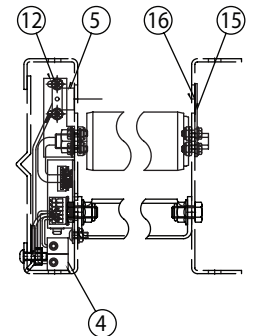
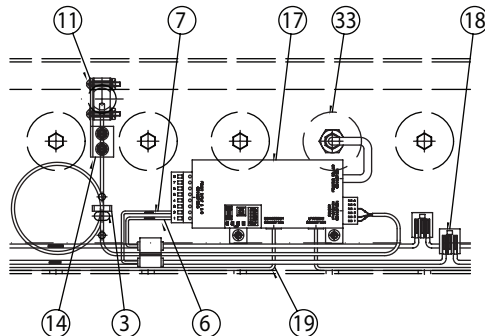
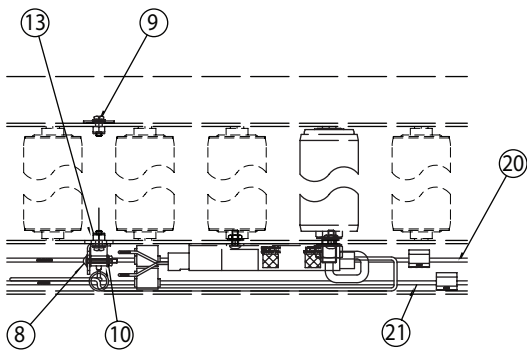
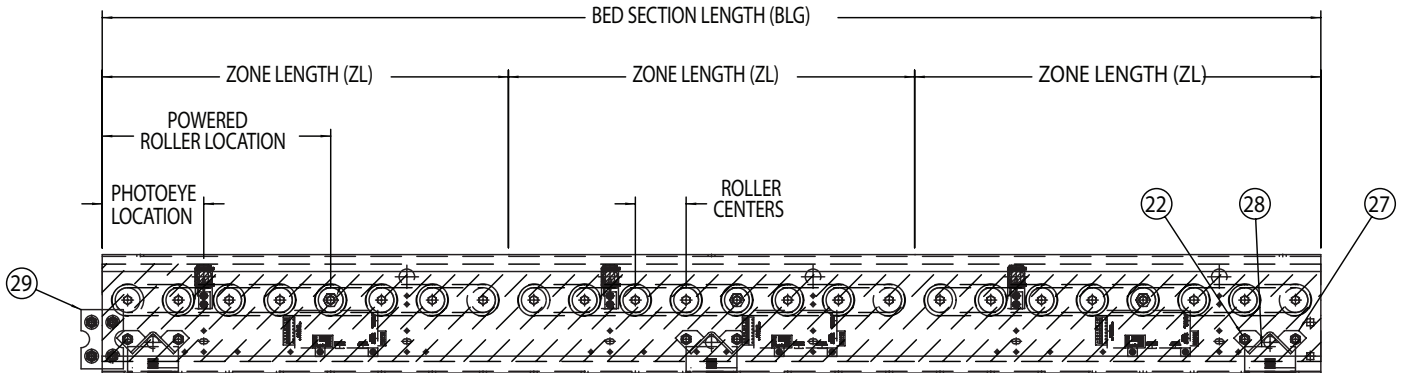
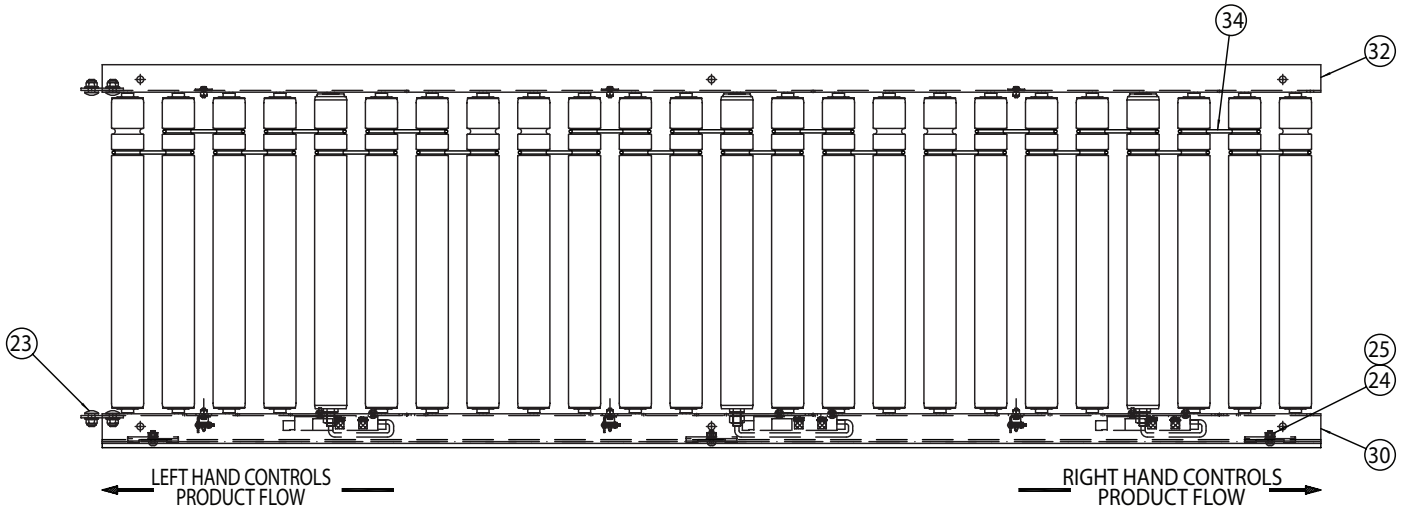
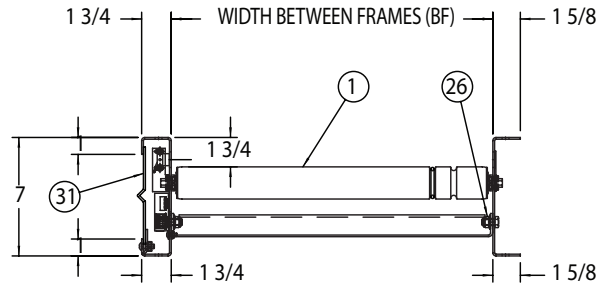
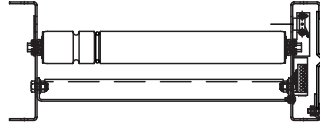

PARTS LIST FOR POWERED ROLLER CONVEYORS

796 PRAC W/ RETROREFLECTIVE PHOTOEYES

ITEM	DESCRIPTION	PART #
1	ROLLER DRIVE HTBL, DOUBLE GROOVED	PB-1505
2	PHOTOEYE MOUNTING BRACKET	M09197
3	REFLECTOR TAPE MOUNT	M09198
4	SPLICE PLATE	M09200
5	90° TRANSPARENT COVER 13"-27"	M09214-BF-90
	45° TRANSPARENT COVER 31"-39"	M09214-BF-45
6	254 TAPERED ROLLER, DOUBLE GROOVED	254T-BF-AD2438
7	FRAME CROSSBRACE	M00119-BF
8	90° INSIDE CHANNEL 13"-27"	M09237
	90° INSIDE CHANNEL 31"-39"	M09238
9	90° OUTSIDE CHANNEL 13"-27"	M09239-BF
	45° OUTSIDE CHANNEL 31"-39"	M09240-BF
10	90° COVER MOUNT WELD ASSY 13"-27"	A29659-BF
	45° COVER MOUNT WELD ASSY 31"-39"	A29657-BF
11	90° COVER RETAINER PLATE 13"-27"	M09244-BF
	45° COVER RETAINER PLATE 31"-39"	M09242-BF
12	BLACK CABLE TIE NT16048CB 6.30"LG.	ELW08412-03
13	WAGO WIRE CONNECTOR 222-413, 28-12	ELW08450
14	#567 SCOTCHLOK TAP CONNECTOR	ELW08451
15	COMMUNICATION CABLE ASSY 36"LG.	ELW08503-36
16	COMMUNICATION CABLE ASSY 72"LG.	ELW08503-72
17	ZL2-F2415 1045389 SICK PHOTOEYE	ELW08590
18	#12 THHN BROWN WIRE (MAINLINE)	ELW08933
19	#12 THHN BLUE WIRE (MAINLINE)	ELW08946
20	#18 TFFN BROWN WIRE (1'EA. TAP-IN)	ELW08947
21	#18 TFFN BLUE WIRE (1'EA. TAP-IN)	ELW08948
22	3/8"-16 X 3/4"LG. HHCS	FSW00355
23	1/4"-20 X 1/2" CARRIAGE BOLT	FSW04251
24	3/8"-16 X 3/4" CARRIAGE BOLT	FSW04355
25	1/4"-20 X 3/4" PAN HEAD PHILLIP MS	FSW08481
26	1/4"-20 CAGE NUT	FSW09099
27	1/4"-20 FLANGE NUT	FSW09101
28	3/8" FLANGED NYLON INSERT NUT	FSW09304-02
29	1"REFLECTOR TAPE BRT-THG-1-100-BAN	MCW06306-01
30	#9000 ZONECONTROL CARD W/HARDWARE	PRW06810
31	3/16"DIA X 9.5"LG DURABELT BLUE HT	VBW71386

ORDERING REPLACEMENT PARTS



ROACH CONVEYORS
808 HIGHWAY 463
TRUMANN, AR 72472
TEL. 870-483-7631

SERIAL NO. 123456

To order any replacement parts or when calling for assistance with any powered conveyor, **ALWAYS** provide the unit serial number. Shown at actual size, this is placed on the conveyor frame near the location of the drive assembly.

To order replacement parts or add-on components, contact the Roach distributor who originally furnished the unit if possible. If this is not possible, contact the National Sales Office at 870-

483-7631 for the name of the authorized Roach distributor in your area. Have unit model number and serial number **BEFORE** calling. Refer to unit drawings (in rear section of handbook) for part numbers if ordering replacement parts.

PARTS LIST FOR POWERED ROLLER CONVEYORS 796 PRAC W/ RETROREFLECTIVE PHOTOEYES

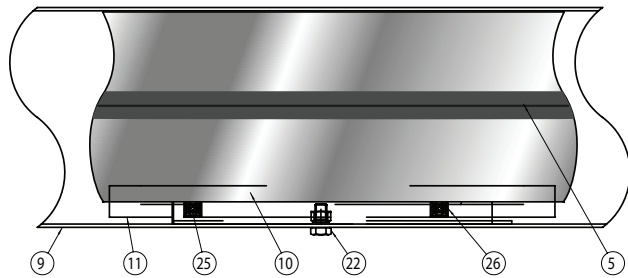
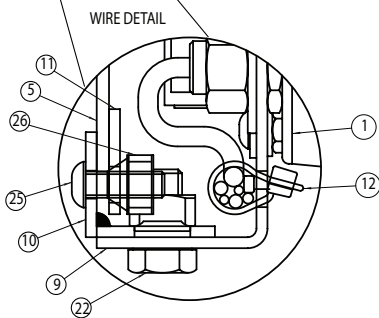
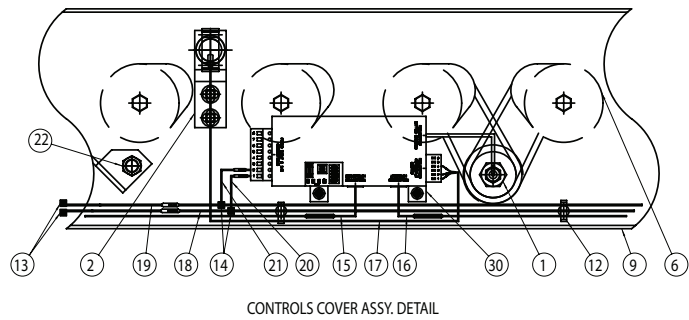
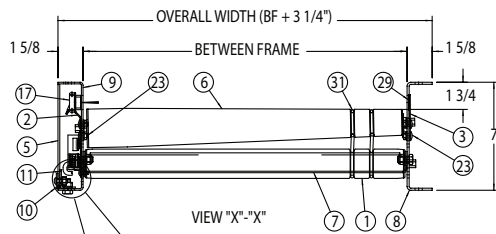
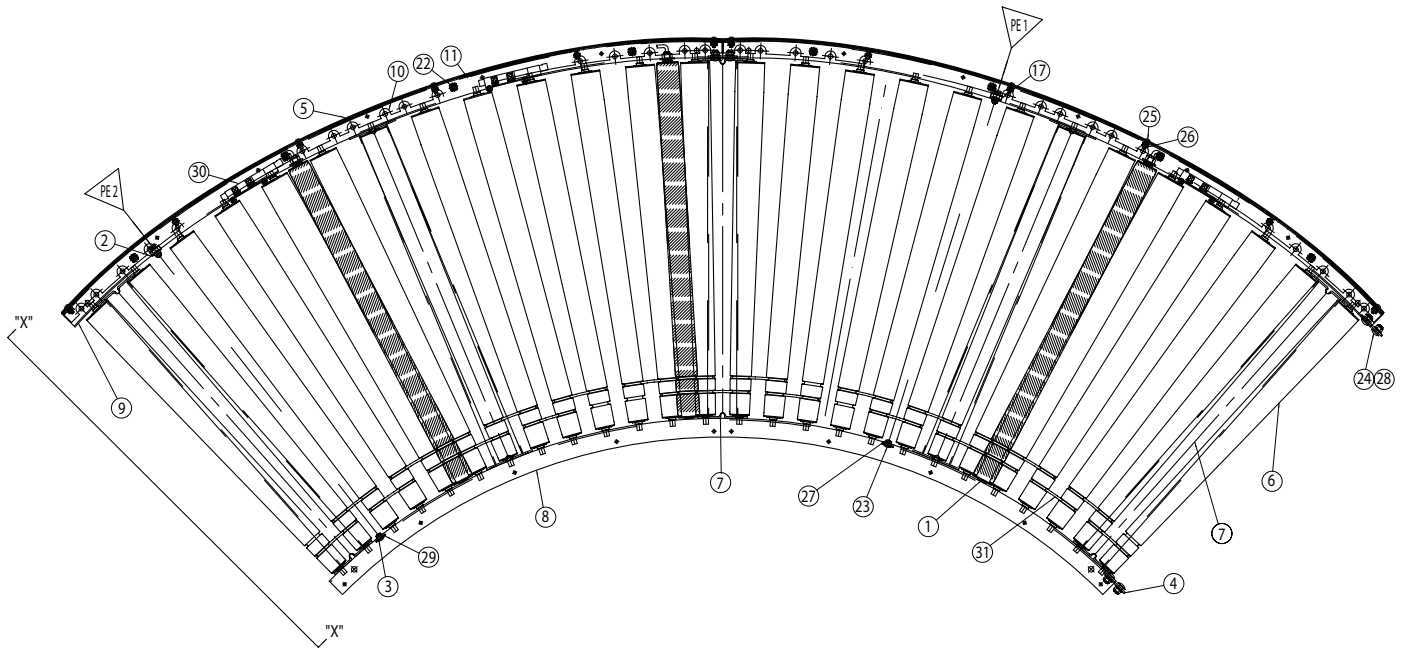

PARTS LIST FOR POWERED ROLLER CONVEYORS 596 PRA W/ RETROREFLECTIVE PHOTOEYES

ITEM	DESCRIPTION	PART #
1	196G DOUBLE GROOVED ROLLER ASSEMBLY	196G-BF-ED2438
2	PHOTOEYE ZONE CONTROL KIT	A29663
3	NT16048CB BLACK CABLE TIE 6.30" LG.	ELW08412-03
4	#567 SCOTCHLOK TAP CONNECTOR	ELW08451
5	ZL2-F2415 1045389 RETROREFLECTIVE PHOTOEYE	ELW08590
6	#18 TFFN BROWN WIRE (TAP FROM CARD TO MAINLINE)	ELW08947
7	#18 TFFN BLUE WIRE (TAP FROM CARD TO MAINLINE)	ELW08948
8	#6-32 X 1" RHSMS	FSW02049
9	#10-24 X 1/2" IHWHMS	FSW02054
10	#6 LOCKWASHER	FSW08476
11	#6 FLAT WASHER	FSW08476-01
12	#6-32 HEX NUT	FSW08477
13	#10-24 NYLON INSERT LOCK NUT	FSW09002
14	PHOTOEYE MOUNTING BRACKET	M09256
15	REFLECTOR TAPE MOUNT	M09257
16	BRT-THG-1-100-BAN 1" WIDE REFLECTOR TAPE	MCW06306-01
17	EC9006 CONTROL CARD WITH HARDWARE	PRW06810
18	222-413 WAGO WIRE CONNECTOR	ELW08450
19	24" LG. COMMUNICATION CABLE ASSEMBLY (18" ZONE)	ELW08503-24
	30" LG. COMMUNICATION CABLE ASSEMBLY (24" ZONE)	ELW08503-30
	36" LG. COMMUNICATION CABLE ASSEMBLY (30" ZONE)	ELW08503-36
20	#12 THHN BROWN WIRE (MAINLINE POWER)	ELW08933
21	#12 THHN BLUE WIRE (MAINLINE POWER)	ELW08946
22	3/8"-16 X 3/4" HHCS	FSW00355
23	3/8"-16 X 3/4" CARRIAGE BOLT	FSW04355
24	1/4"-20 X 3/4" PHPMS	FSW08481
25	1/4"-20 CAGE NUT	FSW09099
26	3/8"-16 NYLON INSERT FLANGE NUT	FSW09304-02
27	FRAME CROSSBRACE	M00119-BF
28	COVER MOUNTING CLAMP	M09199
29	SPLICE PLATE	M09200
30	CONTROLS SIDE CHANNEL	M09202-RC-ZL-LG
31	TRANSPARENT COVER FOR CONTROLS	M09203-LG
32	BELT SIDE CHANNEL	M09255-RC-ZL-LG
33	EC100 1.9 OD 24V DOUBLE GROOVED POWERED ROLLER	PB-1505
34	3/16" DIA. X 9 1/2" LG. DURA-BELT BLUE HT 85A	VBW71386

ORDERING REPLACEMENT PARTS



To order any replacement parts or when calling for assistance with any powered roller conveyor, **ALWAYS** provide the unit serial number. Shown at left, this is placed on the conveyor frame opposite the control side and is typically near the center.

To order replacement parts or add-on components, contact the Roach distributor who originally furnished the unit if possible. If this is not possible, contact the

National Sales Office at 870-483-7631 for the name of the authorized Roach distributor in your area. Have unit model number and serial number **BEFORE** calling. Refer to unit drawings in this handbook for part numbers if ordering replacement parts.

PARTS LIST FOR POWERED ROLLER CONVEYORS

596 PRA W/ RETROREFLECTIVE PHOTOEYES

REFERENCE POINT FOR HAND OF CONTROLS IS TAKEN FROM INFEED END OF CONVEYOR.

LEFT HAND CONTROLS

RIGHT HAND CONTROLS

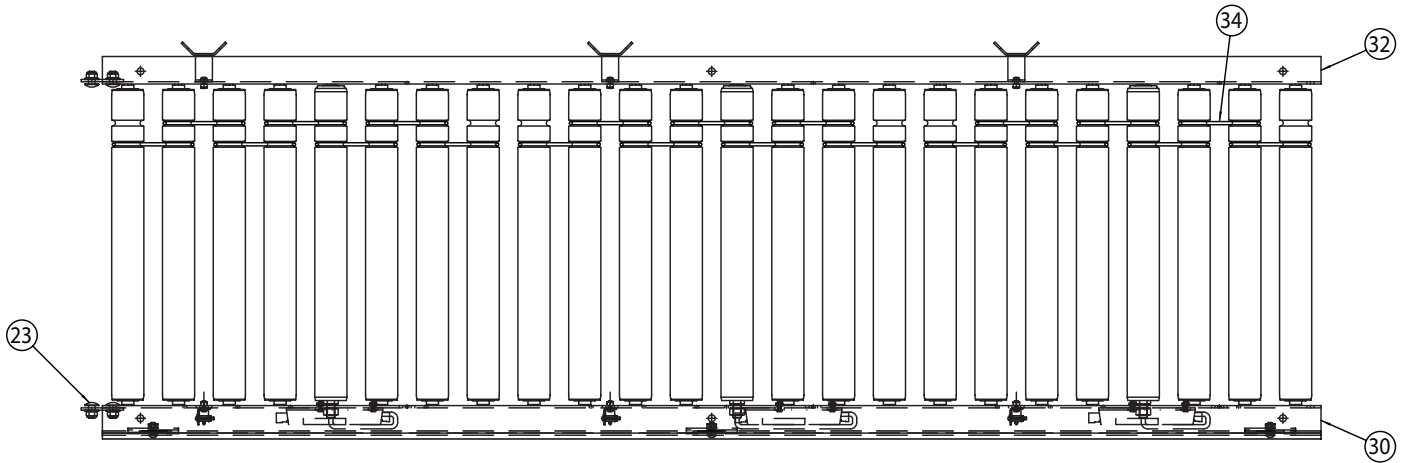
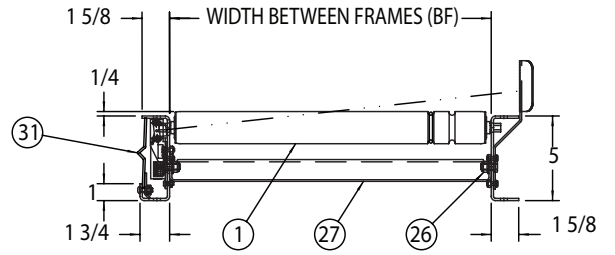
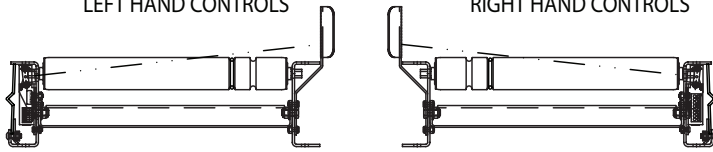

← LEFT HAND CONTROLS PRODUCT FLOW RIGHT HAND CONTROLS PRODUCT FLOW →

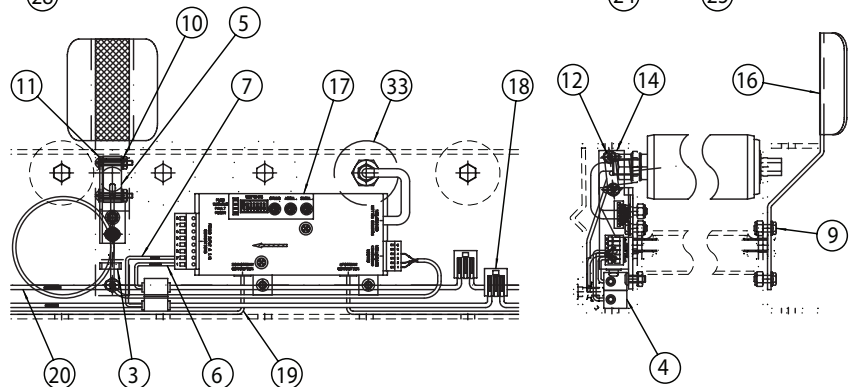
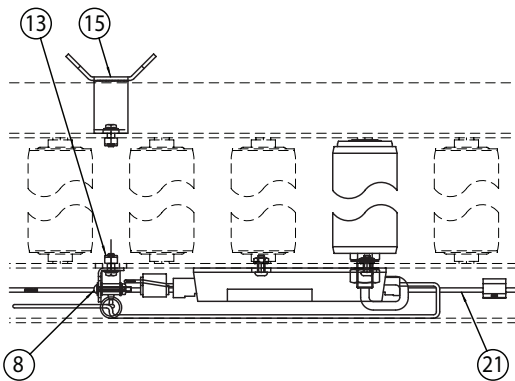
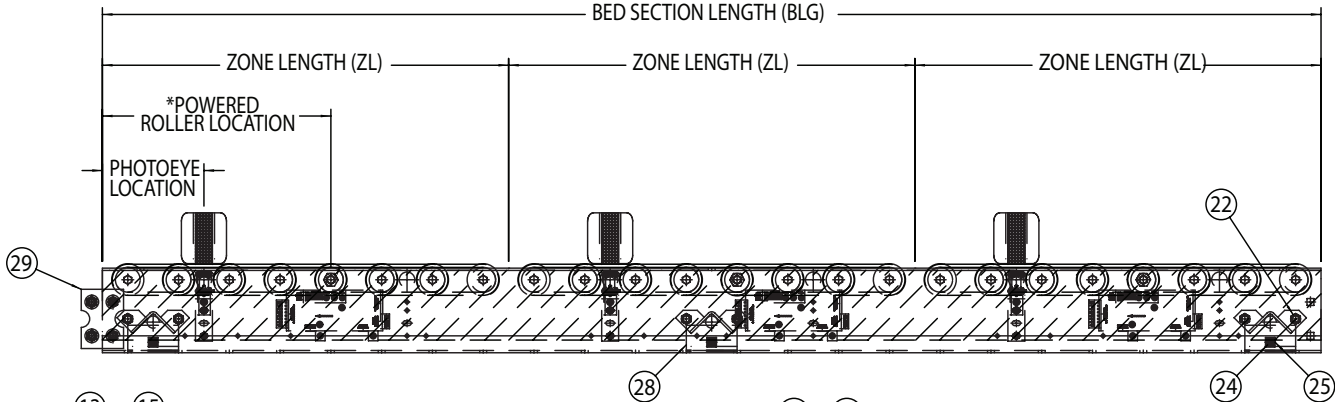

PARTS LIST FOR POWERED ROLLER CONVEYORS

596 PRAC W/ RETROREFLECTIVE PHOTOEYES

ITEM	DESCRIPTION	PART #
1	254 TAPERED ROLLER, DOUBLE GROOVED	254T-BF-AD2438
2	90° COVER MOUNT WELD ASSY	CONTACT FACTORY
3	BLACK CABLE TIE NT16048CB 6.30"LG.	ELW08412-03
4	ZL2-F2415 1045389 PHOTOEYE	ELW08590
5	#6-32 X 1" RHSMS	FSW02049
6	5/16"-18 X 3/4" CARRIAGE BOLT	FSW04259
7	#6 LOCKWASHER	FSW08476
8	#6 FLAT WASHER	FSW08476-01
9	#6-32 HEX NUT	FSW08477
10	5/16"-18 FLANGE NUT	FSW09204
11	PHOTOEYE MOUNTING BRACKET	M09254
12	1" WIDE REFLECTOR TAPE	MCW06306-01
13	BLACK CABLE TIE NT16048CB 6.30"LG.	ELW08412-03
14	WAGO WIRE CONNECTOR 222-413, 28-12	ELW08450
15	#567 SCOTCHLOK TAP CONNECTOR	ELW08451
16	COMMUNICATION CABLE ASSY 36"LG.	ELW08503-36
17	COMMUNICATION CABLE ASSY 72"LG.	ELW08503-72
18	#12 THHN BROWN WIRE (MAINLINE)	ELW08933
19	#12 THHN BLUE WIRE (MAINLINE)	ELW08946
20	#18 TFFN BROWN WIRE (1'EA. TAP-IN)	ELW08947
21	#18 TFFN BLUE WIRE (1'EA. TAP-IN)	ELW08948
22	3/8"-16 X 3/4"LG. HHCS	FSW00355
23	3/8"-16 X 3/4" CARRIAGE BOLT	FSW04355
24	1/4"-20 X 3/4" PAN HEAD PHILLIP MS	FSW08481
25	1/4"-20 CAGE NUT	FSW09099
26	3/8" FLANGED NYLON INSERT NUT	FSW09304-02
27	FRAME CROSSBRACE	M00119-BF
28	SPLICE PLATE	M09200
29	TRANSPARENT COVER	CONTACT FACTORY
30	INSIDE CHANNEL	CONTACT FACTORY
31	OUTSIDE CHANNEL	CONTACT FACTORY
32	COVER RETAINER PLATE	CONTACT FACTORY
33	#9000 ZONECONTROL CARD W/HARDWARE	CONTACT FACTORY
34	EC100 1.9 OD 24V DBL GRV PWRD RLLR	PB-1505
35	3/16"DIA X 9.5"LG DURABELT BLUE HT	VBW71386

ORDERING REPLACEMENT PARTS



To order any replacement parts or when calling for assistance with any powered conveyor, **ALWAYS** provide the unit serial number. Shown at actual size, this is placed on the conveyor frame near the location of the drive assembly.

To order replacement parts or add-on components, contact the Roach distributor who originally furnished the unit if possible. If this is not possible, contact the National Sales Office at 870-

483-7631 for the name of the authorized Roach distributor in your area. Have unit model number and serial number **BEFORE** calling. Refer to unit drawings (in rear section of handbook) for part numbers if ordering replacement parts.

PARTS LIST FOR POWERED ROLLER CONVEYORS 596 PRAC W/ RETROREFLECTIVE PHOTOEYES

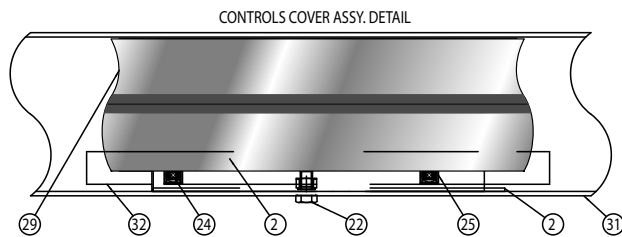
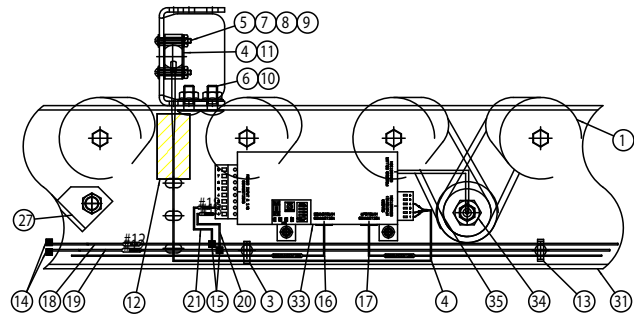
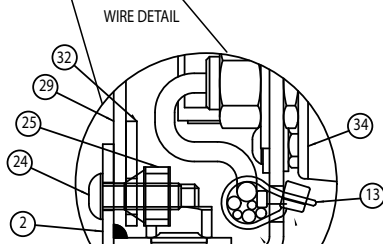
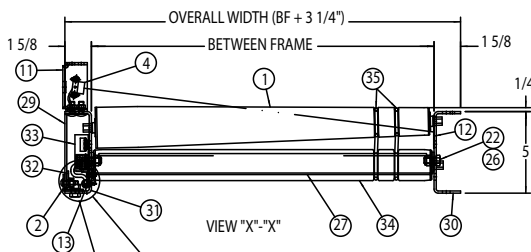
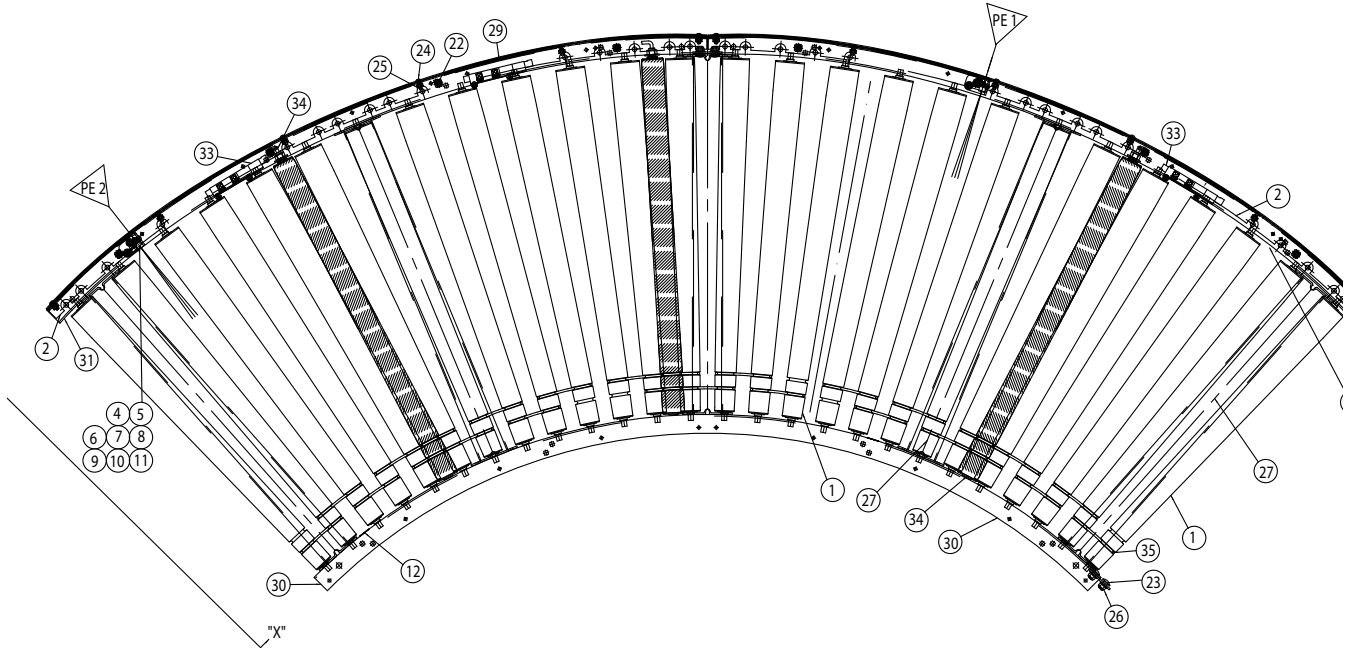

PARTS LIST FOR POWERED ROLLER CONVEYORS

596 PRA W/ DIFFUSE PHOTOEYES

ITEM	DESCRIPTION	PART #
1	196G DOUBLE GROOVED ROLLER ASSEMBLY	196G-BF-ED2438
2	PHOTOEYE ZONE CONTROL KIT	A29662
3	NT16048CB BLACK CABLE TIE 6.30" LG.	ELW08412-03
4	#567 SCOTCHLOK TAP CONNECTOR	ELW08451
5	WTR2-P511S20 DIFFUSE PHOTOEYE	ELW08592
6	#18 TFFN BROWN WIRE (TAP FROM CARD TO MAINLINE)	ELW08947
7	#18 TFFN BLUE WIRE (TAP FROM CARD TO MAINLINE)	ELW08948
8	#8-32 X 1 1/4" RHSMS	FSW02050-02
9	#10-24 X 1/2" IHWHMS	FSW02054
10	#8 FLAT WASHER	FSW08473
11	#10-24 NYLON INSERT LOCK NUT	FSW09002
12	#8-32 FLANGE NUT	FSW09003
13	PHOTOEYE MOUNTING BRACKET	M09254
14	EC9006 CONTROL CARD WITH HARDWARE	PRW06810
15	222-413 WAGO WIRE CONNECTOR	ELW08450
16	24" LG. COMMUNICATION CABLE ASSEMBLY (18" ZONE)	ELW08503-24
	30" LG. COMMUNICATION CABLE ASSEMBLY (24" ZONE)	ELW08503-30
	36" LG. COMMUNICATION CABLE ASSEMBLY (30" ZONE)	ELW08503-36
17	#12 THHN BROWN WIRE (MAINLINE POWER)	ELW08933
18	#12 THHN BLUE WIRE (MAINLINE POWER)	ELW08946
19	3/8"-16 X 3/4" HHCS	FSW00355
20	3/8"-16 X 3/4" CARRIAGE BOLT	FSW04355
21	1/4"-20 X 3/4" PHPMS	FSW08481
22	1/4"-20 CAGE NUT	FSW09099
23	3/8"-16 NYLON INSERT FLANGE NUT	FSW09304-02
24	FRAME CROSSBRACE	M00119-BF
25	COVER MOUNTING CLAMP	M09199
26	SPLICE PLATE	M09200
27	CONTROLS SIDE CHANNEL	M09202-RC-ZL-LG
28	TRANSPARENT COVER FOR CONTROLS	M09203-LG
29	BELT SIDE CHANNEL	M09255-RC-ZL-LG
30	EC100 1.9 OD 24V DOUBLE GROOVED POWERED ROLLER	PB-1505
31	3/16" DIA. X 9 1/2" LG. DURA-BELT BLUE HT 85A	VBW71386

ORDERING REPLACEMENT PARTS



ROACH CONVEYORS
 808 HIGHWAY 463
 TRUMANN, AR 72472
 TEL 870-483-7631

SERIAL NO. 123456

To order any replacement parts or when calling for assistance with any powered roller conveyor, **ALWAYS** provide the unit serial number. Shown at left, this is placed on the conveyor frame opposite the control side and is typically near the center.

To order replacement parts or add-on components, contact the Roach distributor who originally furnished the unit if possible. If this is not possible, contact the

National Sales Office at 870-483-7631 for the name of the authorized Roach distributor in your area. Have unit model number and serial number **BEFORE** calling. Refer to unit drawings in this handbook for part numbers if ordering replacement parts.

PARTS LIST FOR POWERED ROLLER CONVEYORS 596 PRA W/ DIFFUSE PHOTOEYES

REFERENCE POINT FOR HAND OF CONTROLS IS TAKEN FROM INFEED END OF CONVEYOR.

LEFT HAND CONTROLS

RIGHT HAND CONTROLS

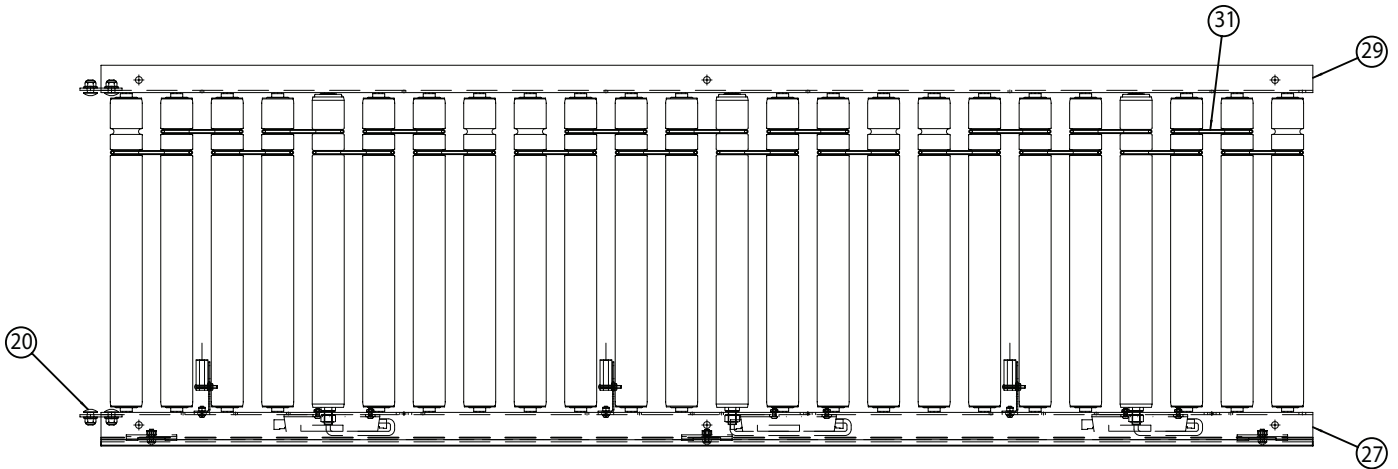
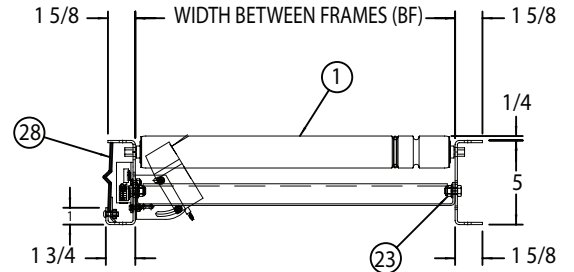
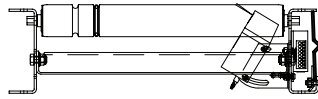
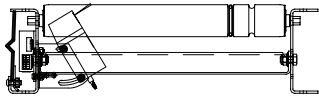

← LEFT HAND CONTROLS
PRODUCT FLOW

RIGHT HAND CONTROLS
PRODUCT FLOW →

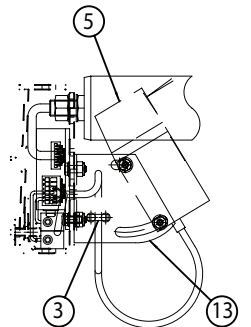
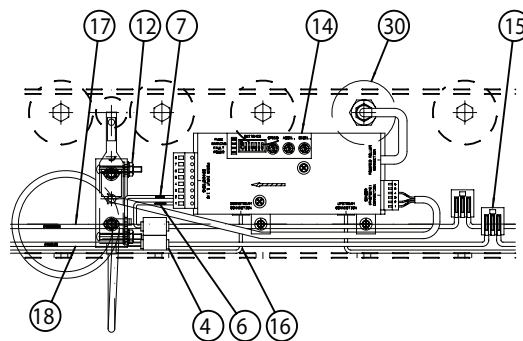
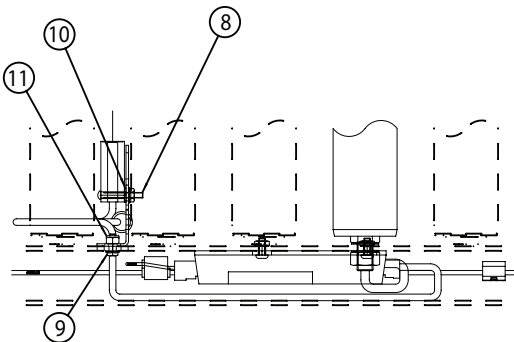
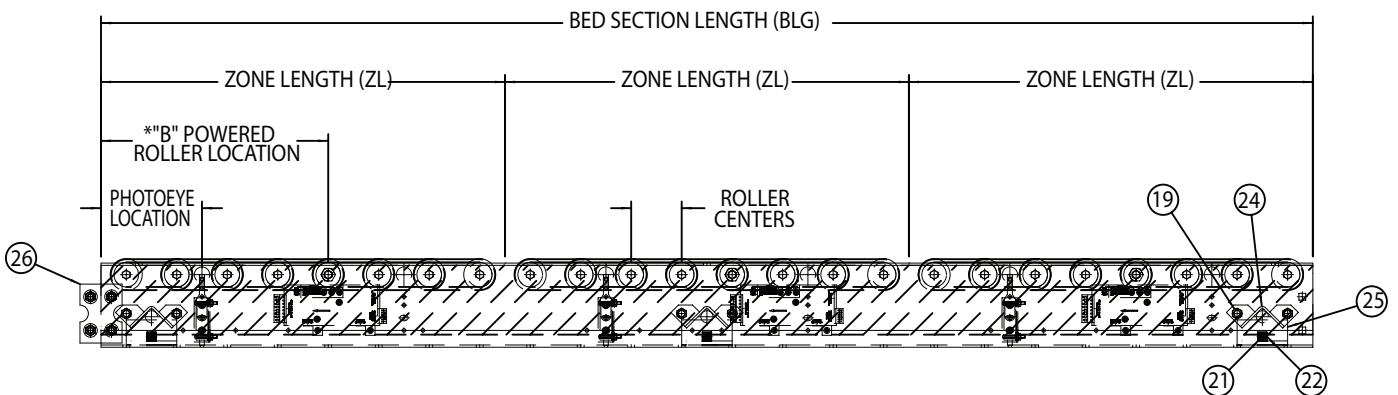

PARTS LIST FOR POWERED ROLLER CONVEYORS

596 PRAC W/ DIFFUSE PHOTOEYES

ITEM	DESCRIPTION	PART #
1	ROLLER DRIVE HTBL, DOUBLE GROOVED	PB-1505
2	PHOTOEYE MOUNTING BRACKET	M09201
3	SPLICE PLATE	M09200
4	TRANSPARENT COVER	CONTACT FACTORY
5	254 TAPERED ROLLER, DOUBLE GROOVED	254T-BF-AD2438
6	FRAME CROSSBRACE	M00119-BF
7	INSIDE CHANNEL	CONTACT FACTORY
8	OUTSIDE CHANNEL	CONTACT FACTORY
9	COVER MOUNT WELD ASSY	CONTACT FACTORY
10	COVER RETAINER	CONTACT FACTORY
11	BLACK CABLE TIE NT16048CB 6.30"LG.	ELW08412-03
12	WAGO WIRE CONNECTOR 222-413, 28-12	ELW08450
13	#567 SCOTCHLOK TAP CONNECTOR	ELW08451
14	COMMUNICATION CABLE ASSY 36"LG.	ELW08503-36
15	COMMUNICATION CABLE ASSY 72"LG.	ELW08503-72
16	WTR2-P511S20 DIFUSE SICK PHOTOEYE	ELW08592
17	#12 THHN BROWN WIRE (MAINLINE)	ELW08933
18	#12 THHN BLUE WIRE (MAINLINE)	ELW08946
19	#18 TFFN BROWN WIRE (1'EA. TAP-IN)	ELW08947
20	#18 TFFN BLUE WIRE (1'EA. TAP-IN)	ELW08948
21	3/8"-16 X 3/4"LG. HHCS	FSW00355
22	#8-32 X 1 1/4" RHSMS	FSW02050-02
23	1/4"-20 X 1/2" CARRIAGE BOLT	FSW04251
24	3/8"-16 X 3/4" CARRIAGE BOLT	FSW04355
25	#8 FLAT WASHER	FSW08473
26	1/4"-20 X 3/4" PAN HEAD PHILLIP MS	FSW08481
27	#8-32 FLANGE NUT	FSW09003
28	1/4"-20 CAGE NUT	FSW09099
29	1/4"-20 FLANGE NUT	FSW09101
30	3/8" FLANGED NYLON INSERT NUT	FSW09304-02
31	#9000 ZONECONTROL CARD W/HARDWARE	PRW06810
32	3/16"DIA X 9.5"LG DURABELT BLUE HT	VBW71386

ORDERING REPLACEMENT PARTS



To order any replacement parts or when calling for assistance with any powered conveyor, **ALWAYS** provide the unit serial number. Shown at actual size, this is placed on the conveyor frame near the location of the drive assembly.

To order replacement parts or add-on components, contact the Roach distributor who originally furnished the unit

if possible. If this is not possible, contact the National Sales Office at 870-

483-7631 for the name of the authorized Roach distributor in your area. Have unit model number and serial number **BEFORE** calling.

Refer to unit drawings (in rear section of handbook) for part numbers if ordering replacement parts.

PARTS LIST FOR POWERED ROLLER CONVEYORS

596 PRAC W/ DIFFUSE PHOTOEYES

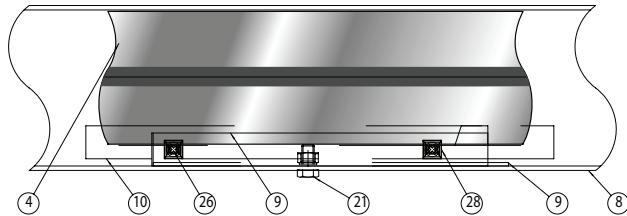
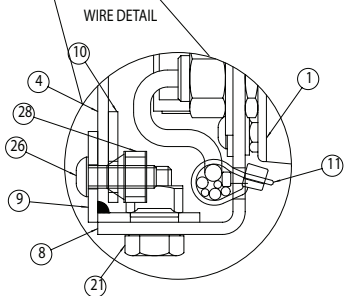
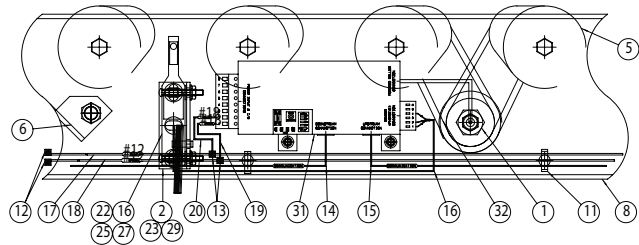
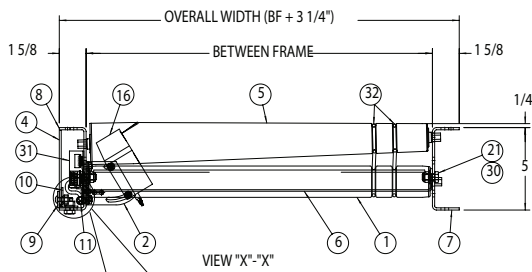
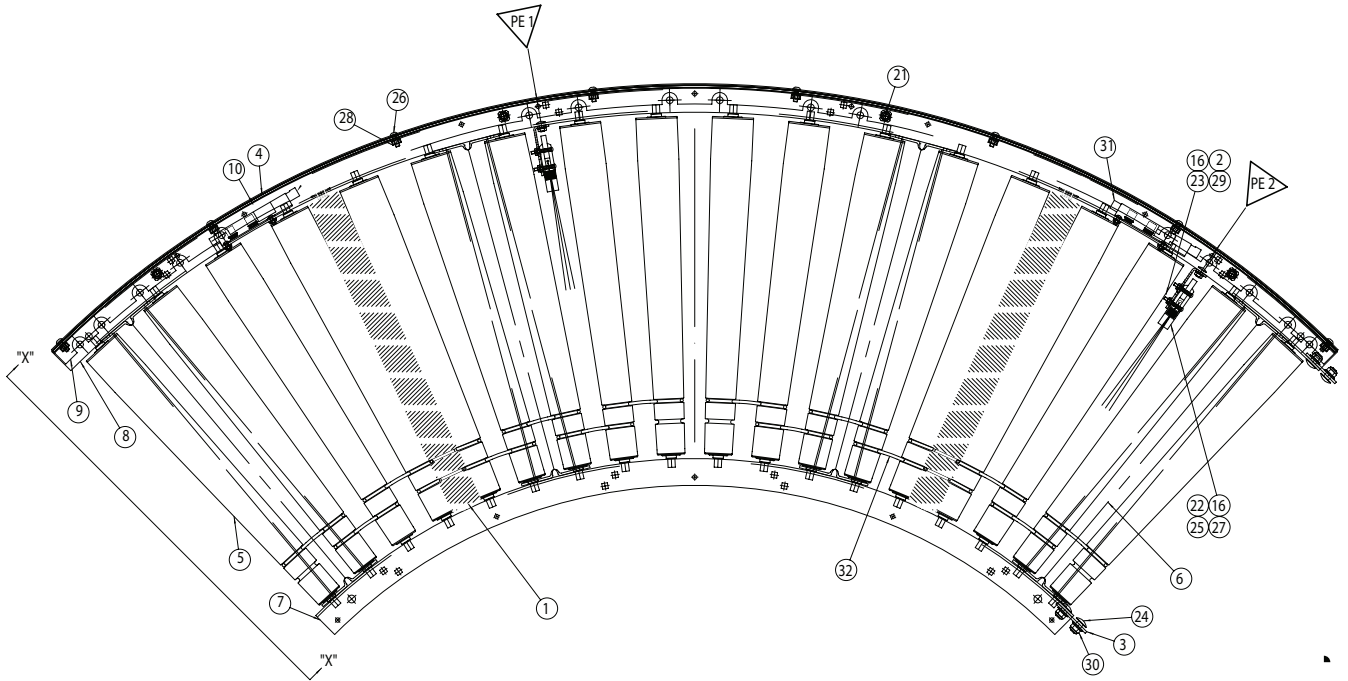

PARTS LIST FOR POWERED ROLLER CONVEYORS

796 PRA-PV W/ RETROREFLECTIVE PHOTOEYES

ITEM	DESCRIPTION	PART #
1	196G POLY-V ROLLER ASSEMBLY	196G-BF-E-PV
2	PHOTOEYE ZONE CONTROL KIT	A29665
3	NT16048CB BLACK CABLE TIE 6.30" LG.	ELW08412-03
4	#567 SCOTCHLOK TAP CONNECTOR	ELW08451
5	ZL2-F2415 1045389 RETROREFLECTIVE PHOTOEYE	ELW08590
6	#18 TFFN BROWN WIRE (TAP FROM CARD TO MAINLINE)	ELW08947
7	#18 TFFN BLUE WIRE (TAP FROM CARD TO MAINLINE)	ELW08948
8	#6-32 X 1" RHSMS	FSW02049
9	#10-24 X 1/2" IHWHMS	FSW02054
10	#6 LOCKWASHER	FSW08476
11	#6 FLAT WASHER	FSW08476-01
12	#6-32 HEX NUT	FSW08477
13	#10-24 NYLON INSERT LOCK NUT	FSW09002
14	PHOTOEYE MOUNTING BRACKET	M09256
15	REFLECTOR TAPE MOUNT	M09258
16	BRT-THG-1-100-BAN 1" WIDE REFLECTOR TAPE	MCW06306-01
17	EC9006 CONTROL CARD WITH HARDWARE	PRW06810
18	222-413 WAGO WIRE CONNECTOR	ELW08450
19	30" LG. COMMUNICATION CABLE ASSEMBLY (24" ZONE)	ELW08503-30
	42" LG. COMMUNICATION CABLE ASSEMBLY (36" ZONE)	ELW08503-42
	54" LG. COMMUNICATION CABLE ASSEMBLY (48" ZONE)	ELW08503-54
20	#12 THHN BROWN WIRE (MAINLINE POWER)	ELW08933
21	#12 THHN BLUE WIRE (MAINLINE POWER)	ELW08946
22	3/8"-16 X 3/4" HHCS	FSW00355
23	#10-24 X 1/2" IHWHMS	FSW02054
24	3/8"-16 X 3/4" CARRIAGE BOLT	FSW04355
25	1/4"-20 X 3/4" PHPMS	FSW08481
26	#10-24 NYLON INSERT LOCK NUT	FSW09002
27	1/4"-20 CAGE NUT	FSW09099
28	3/8"-16 NYLON INSERT FLANGE NUT	FSW09304-02
29	FRAME CROSSBRACE	M00119-BF
30	COVER MOUNTING CLAMP	M09199
31	SPLICE PLATE	M09200
32	CONTROLS SIDE CHANNEL	M09204-RC-ZL-LG
33	TRANSPARENT COVER FOR CONTROLS	M09205-LG
34	BELT SIDE CHANNEL	M09261-RC-ZL-LG
35	FINGER GUARD 3" RC	M09262
	FINGER GUARD 4" RC	M09263
36	EC110 1.9 OD 24V POLY-V POWERED ROLLER	PB-1507
37	2-RIB POLY-V BELT 3" RC	VBW71450
	3-RIB POLY-V BELT 3" RC	VBW71451
	2-RIB POLY-V BELT 4" RC	VBW71453
	3-RIB POLY-V BELT 4" RC	VBW71454

ORDERING REPLACEMENT PARTS



To order any replacement parts or when calling for assistance with any powered roller conveyor, **ALWAYS** provide the unit serial number. Shown at left, this is placed on the conveyor frame opposite the control side and is typically near the center.

To order replacement parts or add-on components, contact the Roach distributor who originally furnished the unit if possible. If this is not possible, contact the

National Sales Office at 870-483-7631 for the name of the authorized Roach distributor in your area. Have unit model number and serial number **BEFORE** calling. Refer to unit drawings in this handbook for part numbers if ordering replacement parts.

PARTS LIST FOR POWERED ROLLER CONVEYORS 796 PRA-PV W/ RETROREFLECTIVE PHOTOEYES

REFERENCE POINT FOR HAND OF CONTROLS IS TAKEN FROM INFEED END OF CONVEYOR.

LEFT HAND CONTROLS

RIGHT HAND CONTROLS

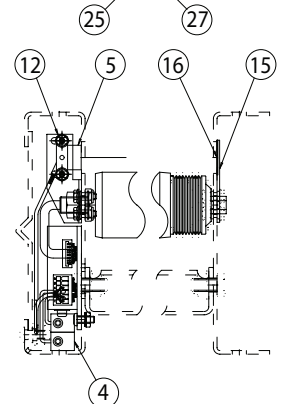
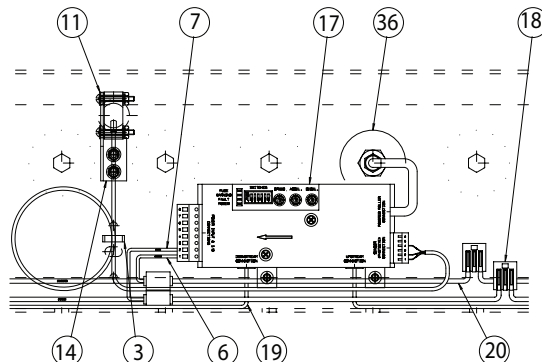
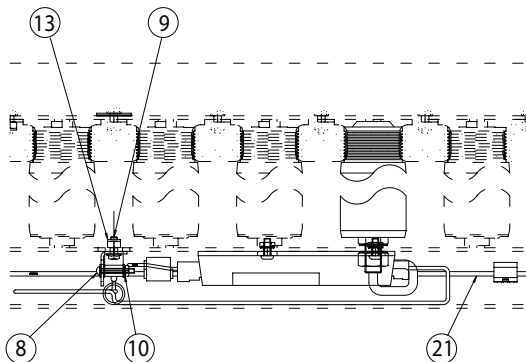
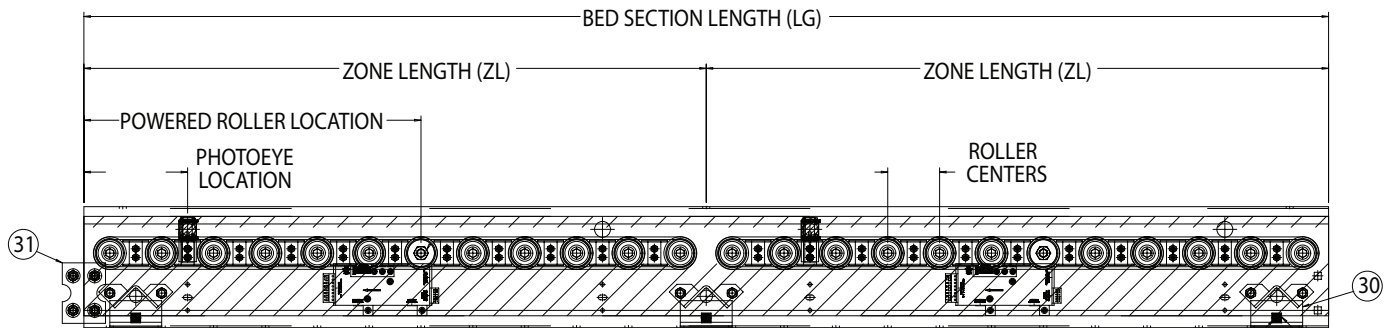
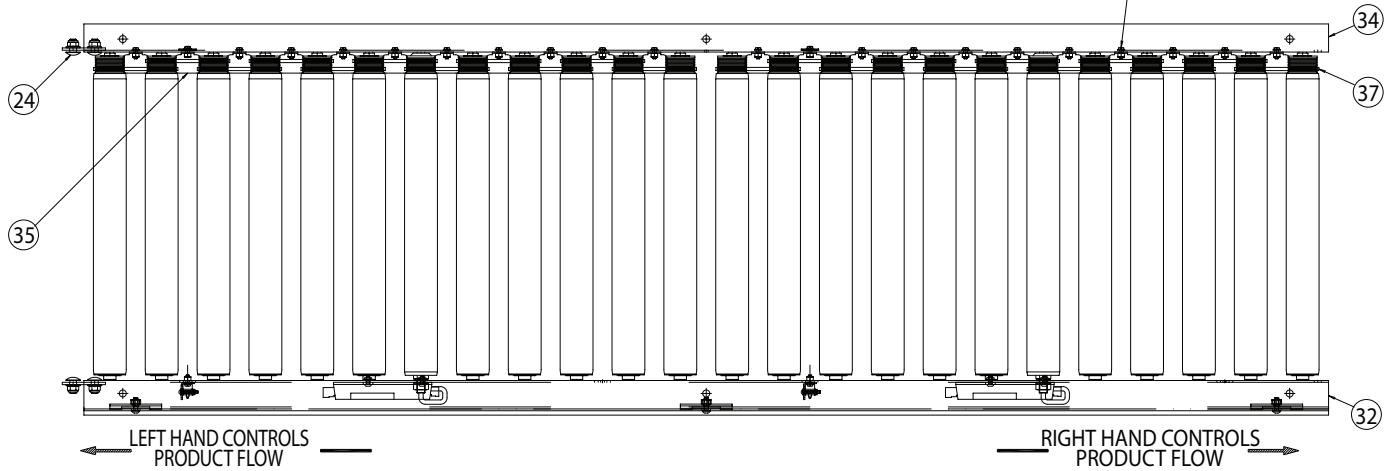
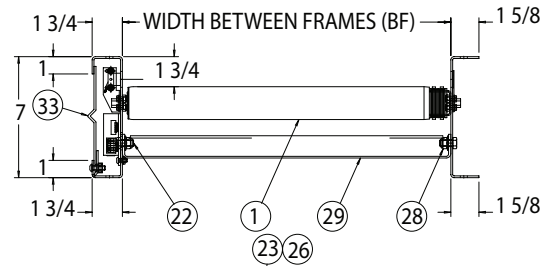
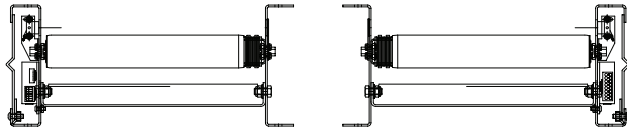

PARTS LIST FOR POWERED ROLLER CONVEYORS

596 PRA-PV W/ RETROREFLECTIVE PHOTOEYES

ITEM	DESCRIPTION	PART #
1	196G POLY-V ROLLER ASSEMBLY	196G-BF-E-PV
2	PHOTOEYE ZONE CONTROL KIT	A29663
3	NT16048CB BLACK CABLE TIE 6.30" LG.	ELW08412-03
4	#567 SCOTCHLOK TAP CONNECTOR	ELW08451
5	ZL2-F2415 1045389 RETROREFLECTIVE PHOTOEYE	ELW08590
6	#18 TFFN BROWN WIRE (TAP FROM CARD TO MAINLINE)	ELW08947
7	#18 TFFN BLUE WIRE (TAP FROM CARD TO MAINLINE)	ELW08948
8	#6-32 X 1" RHSMS	FSW02049
9	#10-24 X 1/2" IHWHMS	FSW02054
10	#6 LOCKWASHER	FSW08476
11	#6 FLAT WASHER	FSW08476-01
12	#6-32 HEX NUT	FSW08477
13	#10-24 NYLON INSERT LOCK NUT	FSW09002
14	PHOTOEYE MOUNTING BRACKET	M09256
15	REFLECTOR TAPE MOUNT	M09257
16	BRT-THG-1-100-BAN 1" WIDE REFLECTOR TAPE	MCW06306-01
17	EC9006 CONTROL CARD WITH HARDWARE	PRW06810
18	222-413 WAGO WIRE CONNECTOR	ELW08450
19	30" LG. COMMUNICATION CABLE ASSEMBLY (24" ZONE)	ELW08503-30
	42" LG. COMMUNICATION CABLE ASSEMBLY (36" ZONE)	ELW08503-42
	54" LG. COMMUNICATION CABLE ASSEMBLY (48" ZONE)	ELW08503-54
20	#12 THHN BROWN WIRE (MAINLINE POWER)	ELW08933
21	#12 THHN BLUE WIRE (MAINLINE POWER)	ELW08946
22	3/8"-16 X 3/4" HHCS	FSW00355
23	#10-24 X 1/2" IHWHMS	FSW02054
24	3/8"-16 X 3/4" CARRIAGE BOLT	FSW04355
25	1/4"-20 X 3/4" PHPMS	FSW08481
26	#10-24 NYLON INSERT LOCK NUT	FSW09002
27	1/4"-20 CAGE NUT	FSW09099
28	3/8"-16 NYLON INSERT FLANGE NUT	FSW09304-02
29	FRAME CROSSBRACE	M00119-BF
30	COVER MOUNTING CLAMP	M09199
31	SPLICE PLATE	M09200
32	CONTROLS SIDE CHANNEL	M09202-RC-ZL-LG
33	TRANSPARENT COVER FOR CONTROLS	M09203-LG
34	BELT SIDE CHANNEL	M09260-RC-ZL-LG
35	FINGER GUARD 3" RC	M09262
	FINGER GUARD 4" RC	M09263
36	EC110 1.9 OD 24V POLY-V POWERED ROLLER	PB-1507
37	2-RIB POLY-V BELT 3" RC	VBW71450
	3-RIB POLY-V BELT 3" RC	VBW71451
	2-RIB POLY-V BELT 4" RC	VBW71453
	3-RIB POLY-V BELT 4" RC	VBW71454

ORDERING REPLACEMENT PARTS



To order any replacement parts or when calling for assistance with any powered roller conveyor, **ALWAYS** provide the unit serial number. Shown at left, this is placed on the conveyor frame opposite the control side and is typically near the center.

To order replacement parts or add-on components, contact the Roach distributor who originally furnished the unit if possible. If this is not possible, contact the

National Sales Office at 870-483-7631 for the name of the authorized Roach distributor in your area. Have unit model number and serial number **BEFORE** calling. Refer to unit drawings in this handbook for part numbers if ordering replacement parts.

PARTS LIST FOR POWERED ROLLER CONVEYORS

596 PRA-PV W/ RETROREFLECTIVE PHOTOEYES

REFERENCE POINT FOR HAND OF CONTROLS IS TAKEN FROM INFEED END OF CONVEYOR.

LEFT HAND CONTROLS

RIGHT HAND CONTROLS

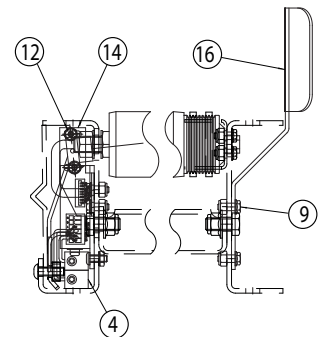
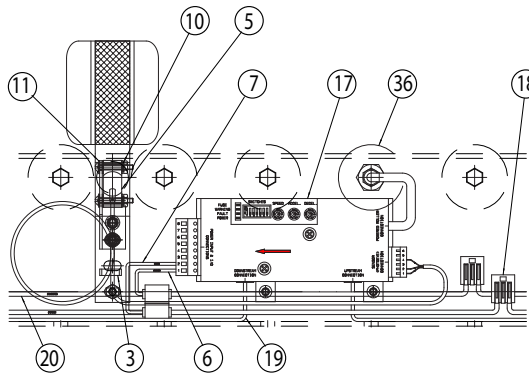
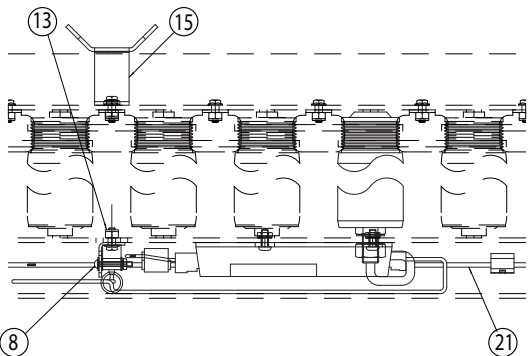
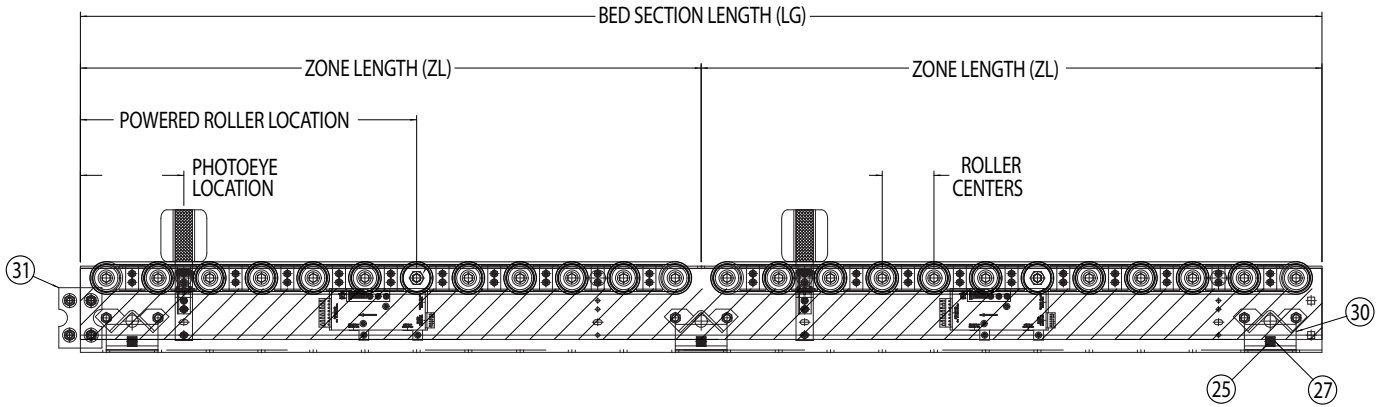
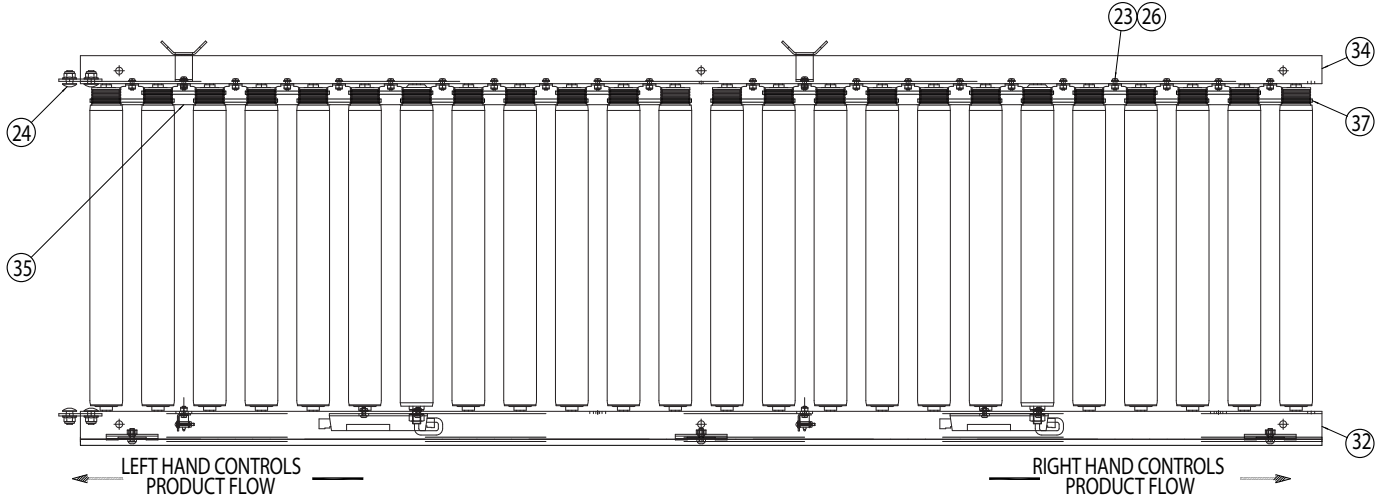
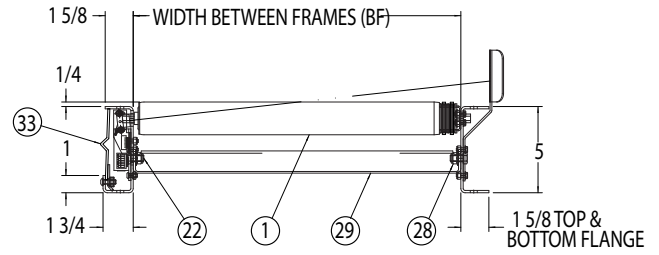
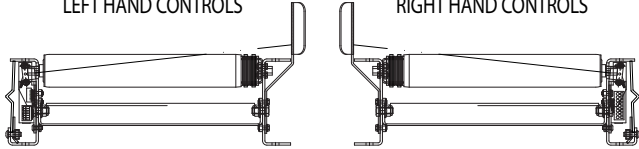



ROACH CONVEYORS

WARRANTY

- Materials used by Roach Conveyors are of good quality.
- Any part proving to be defective in materials or workmanship upon Roach inspection, will be replaced at NO cost, FOB, Trumann, Arkansas, for one year. Installation expense will be paid by others.
- Roach liability includes furnishing said part or parts; Roach is not liable for consequential damages, such as loss of profit, delays or expenses incurred by failure of said part or parts.
- Failure due to abuse, incorrect adjustments, exposure to corrosive or abrasive environment or operation under damp conditions does not constitute failure due to defects in workmanship or materials.
- Component parts not manufactured by Roach (motors, gear reducers, etc.) will be repaired or replaced at the option of their manufacturer. Contact nearest authorized service center for all warranty claims.

NOTE: Motors or gear reducers tampered with before inspection shall be considered free of ALL Warranty Claims.

--All specifications are subject to change without notice--
--Drawings are intended for illustration ONLY and are not to scale--

808 HIGHWAY 463
TRUMANN, ARKANSAS 72472-1310
Tel 870-483-7631 Fax 870-483-7049
info@roachconveyors.com
www.roachconveyors.com



808 HIGHWAY 463
TRUMANN, ARKANSAS 72472-1310
Tel 870-483-7631 Fax 870-483-7049
info@roachconveyors.com
www.roachconveyors.com