

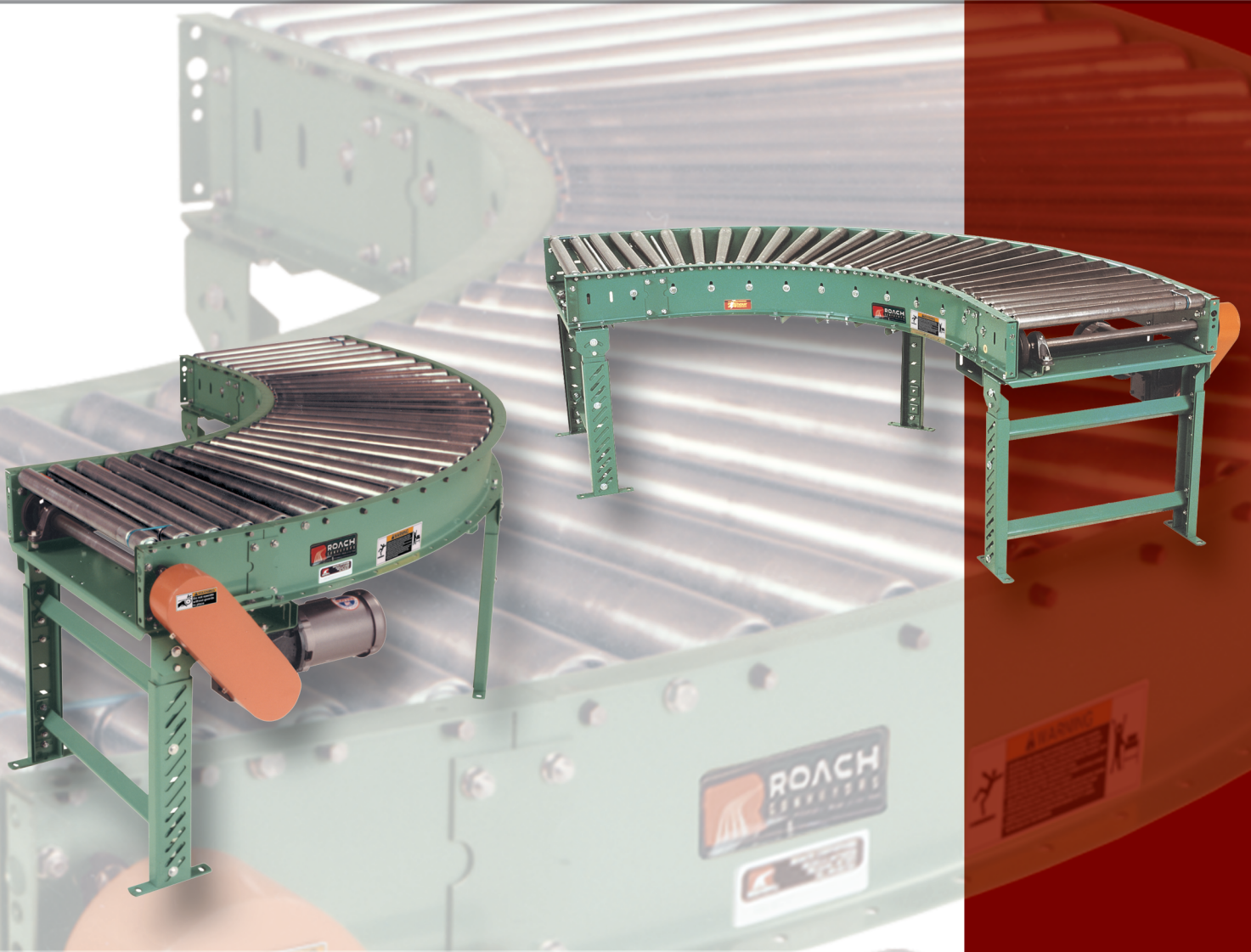

OWNER'S MANUAL



Belt Driven Live Roller Curves/Spurs

Model 138LRC • 196LRC • 138LRCS • 196LRCS

DO NOT OPERATE BEFORE READING THIS HANDBOOK
KEEP IN A SAFE PLACE – DO NOT DISCARD

TECH HANDBOOK FOR LIVE ROLLER CURVES/SPURS

TABLE OF CONTENTS

TECH HANDBOOK FOR BELT DRIVEN LIVE ROLLERS	2	MAINTENANCE SAFETY PRECAUTIONS	12
-Caution Labels	2	-Before Performing Maintenance.....	12
CAUTIONS, WARNINGS AND HAZARDS	3	-Maintenance and Follow-Up Details.....	12
-Introduction.....	3	MAINTENANCE AND LUBRICATION	13
-Cautions, Warnings and Hazards	3	-Periodic Maintenance Schedules	13
SAFETY INFORMATION / RECEIVING & INSPECTION	4	-Recommended Lubricants.....	14
-Important Safety Guidelines	4	-Report on Miscellaneous Maintenance Performed, Chart 1	14
-Shortages, Damages and Return Authorizations	4	TROUBLE SHOOTING AND REPLACEMENT PARTS	15
GENERAL INSTALLATION INFORMATION	5	-Trouble Shooting / Serial Plate	15
-Slave Drive / Mating to Other Conveyors	5	MODEL 138LRC	16
-Identifying / Installing Permanent Floor Supports	5	-Parts List for Unit With End Drive / Side Mount End Drive.....	16
CEILING HANGERS AND POLYTIER SUPPORTS.....	6	-Illustrations for Unit With End Drive / Side Mount End Drive	17
-Installation of Ceiling Hangers	6	MODEL 196LRC	18
-Installation of Polytier Supports.....	6	-Parts List for Unit With End Drive / Side Mount End Drive.....	18
INSTALLATION OF BELTING.....	7	-Illustrations for Unit With End Drive / Side Mount End Drive	19
-V-Belt Connections	7	MODEL 138LRCS	20
-Adjusting V-Belt Tension.....	7	-Parts List for Unit With End Drive / Side Mount End Drive.....	20
-V-Belt Drive Pressure Adjustment	8	-Illustrations for Unit With End Drive / Side Mount End Drive	21
-Replacing V-Belt And Sheaves.....	8	MODEL 196LRCS	22
V-BELT PATH.....	9	-Parts List for Unit With End Drive / Side Mount End Drive.....	22
-V-Belt Path for Spurs And Curves.....	9	-Illustrations for Unit With End Drive / Side Mount End Drive	23
START-UP PROCEDURES	10	WARRANTY.....	24
-Drive Chain and Sprocket Alignment	10		
-Drive Chain and Sprocket Tension.....	10		
-Gear Reducer Vent Plug	11		
-Preparing for Initial Start-Up.....	11		

WARNING LABELS



ABOVE: Label attached to all protective guards (drives, roller guards, etc.)



ABOVE: Label placed near all pulleys (center drives, end drives, tail pulleys)

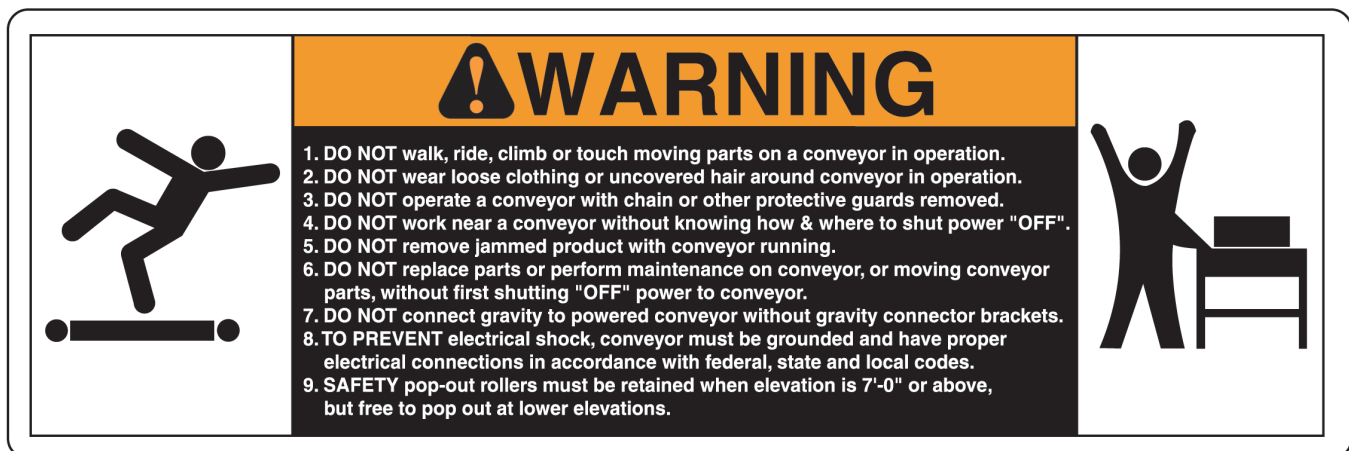

ABOVE: Label placed near all drive assemblies and at 30' intervals

CAUTIONS, WARNINGS AND HAZARDS

INTRODUCTION

This manual was prepared as a "how-to-guide" for installers, end-users and maintenance personnel. It is also intended to educate both owner (purchaser) and all individuals working around the unit, of potential hazards.

With proper installation and maintenance, conveyors are essential for achieving a variety of functions essential in today's industrial marketplace. By following a simple, periodic maintenance schedule, the life of a typical conveyor (or, most any type of machinery-including our automobiles!) will increase when compared to a

similar unit in an application receiving little or no maintenance. You may find that a conveyor can become your best workplace friend by following simple safety guidelines. Failure to follow even the most basic safety suggestions can result in serious personal injury.

Conveyors contain many moving parts-pulleys, belting, chains, sprockets, shafts, rollers, etc. Therefore, it is imperative to become familiar with basic unit operation and know all points of potential hazards.

Remember, when working around or near conveyors (and any industrial machinery)

it is your responsibility to become familiar with the unit, to know potential hazards (many are noted with caution labels) and to operate unit in strict accordance with the safety guidelines in this manual.

Keep this manual in a safe place for future reference. It should be placed where appropriate personnel may maintain proper maintenance and records.











This manual must be read by all new users before operating or working near this unit.

WARNING

**DO NOT OPERATE BEFORE READING THIS MANUAL!
KEEP IN SAFE PLACE--DO NOT DISCARD!**

CAUTIONS, WARNINGS AND HAZARDS

WARNING

-  ALWAYS anchor permanent supports to floor (or mounting surface). Use 3/8" x 2-1/2" (or longer) wedge anchors for permanent installation in concrete flooring.
-  It is the responsibility of the customer and installation personnel to supply and install net or mesh guarding on overhead mounted conveyors to prevent product and/or debris from falling to floor in areas where required.
-  Safety finger guards must NOT be removed from V-belt driven live roller curves or spurs. If guard is removed for maintenance or other purposes, conveyor must NOT be placed into operation until All finger guards have been replaced.
-  Belt must be kept in good condition for safe work environment.
-  Drive chain guards MUST be replaced after installation or maintenance before unit start-up. Also, guards used to cover slave drive connections for slave driven curves or spurs must be replaced prior to start-up after installation or maintenance.
-  To check drive sprocket alignment, shut "OFF" and lock out power source before attempting ANY adjustments.
-  To check drive sprocket tension, shut "OFF" and lock out power source before ANY adjustments are attempted.
-  To check drive sprocket tension, shut "OFF" and lock out power source before ANY adjustments are attempted.
-  Electrical controls must be designed by a qualified electrical engineer to ensure that appropriate safety features (emergency stops, pull cords, switches, etc.) are installed on unit for safe operation. Before conveyor start-up, all operators and other personnel coming in contact with unit must be properly trained and must have read accompanying Tech Handbook.
-  Only trained personnel shall perform maintenance functions. Before maintenance operations are performed, shut conveyor "OFF" and lock out power source to prevent unauthorized start-up. When maintenance is completed, only authorized personnel shall be permitted to start conveyor following maintenance or other emergency shut-off.

SAFETY INFORMATION / RECEIVING & INSPECTION

IMPORTANT SAFETY GUIDELINES

! WARNING

WARNING: All personnel coming in contact with this conveyor should be aware of the following safety guidelines **BEFORE USING OR WORKING AROUND CONVEYOR**. **NOTE:** ALWAYS notify Roach Manufacturing® whenever any conveyor is used in an application or condition other than was originally intended. Failure to notify Roach® may allow conveyor to be operated in a hazardous operating condition. Injuries resulting from negligence or violation of safety instructions hereby removes responsibility of product liability claims from Roach®. Any violation of above safety instructions hereby removes all product liability claims from Roach.

! Do not operate conveyor with protective guards removed. This includes chain guards, belt guards, snub roller guards, center drive guards and any other safety guard.

! Do not walk, ride, climb, or touch moving parts on a conveyor in operation.

! Do not wear loose clothing or uncovered hair around conveyor.

! Do not work near conveyor without knowing how & where to shut power "OFF" and lock out power source.

! Do not remove jammed product with conveyor running.

! Do not replace parts or perform maintenance on conveyor, or moving conveyor parts, without first shutting "OFF" power to conveyor and locking out power source.

! Do not connect gravity to powered conveyor without safety gravity connector brackets.

! To prevent electrical shock, conveyor must be grounded, and have proper electrical connections in accordance with federal, state, and local codes.

! Safety pop out rollers in conveyors installed above 7'-0" elevation must be retained by guard rail, clips, etc. Safety pop out rollers must be allowed to pop out

when conveyors are installed at or below 7'-0" elevation.

! It is the responsibility of conveyor end-user to comply with all safety standards including OSHA and other federal, state, and local codes or regulations. Install protective guarding and other related safety precautionary equipment to eliminate hazardous operating conditions which may exist when two or more vendors supply machinery for related use.

! Any violation of above safety instructions hereby removes all product liability claims from Roach Manufacturing Corporation®.

SHORTAGES, DAMAGES AND RETURN AUTHORIZATIONS

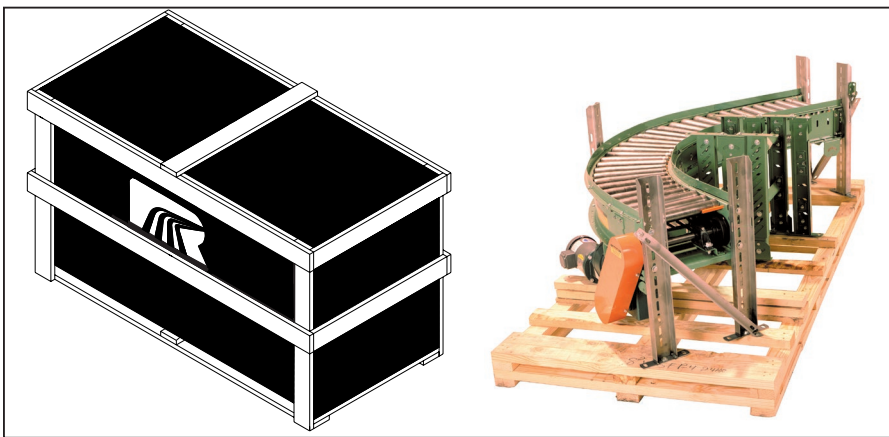

Before uncrating, check quantity of items received against bill of lading to confirm that all equipment has been received. Next, determine if any damage has occurred. Damage and/or shortage in shipment should be reported immediately to both Roach and carrier. Obtain signed damage report from carrier agent and send copy to Roach. Do not repair any damage before obtaining this report.

Finally, consult factory to determine if entire shipment must be returned to factory for repair or if a replacement order should be entered for replacement equipment.

Therefore, it is imperative that the bill of lading (or, accompanying freight documentation) be checked to ensure receipt of ALL units ordered including ALL accessories.

NOTE: Do not return goods to factory without prior, written return authorization. Unauthorized returns are subject to refusal at factory. Also, some items (electric motors, gearbox, etc.) may be shipped direct from their manufacturer. Thus, two or more separate shipments may be required to receive all equipment.

After receipt and initial inspection, carefully remove crating and look for essential components and specific accessories that may have been boxed and attached (or 'banded') to crating material such as guard rails and hardware which may be packaged and shipped in this manner. Save all hardware for subsequent use by installation personnel.

GENERAL INSTALLATION INFORMATION

SLAVE DRIVE / MATING TO OTHER CONVEYORS

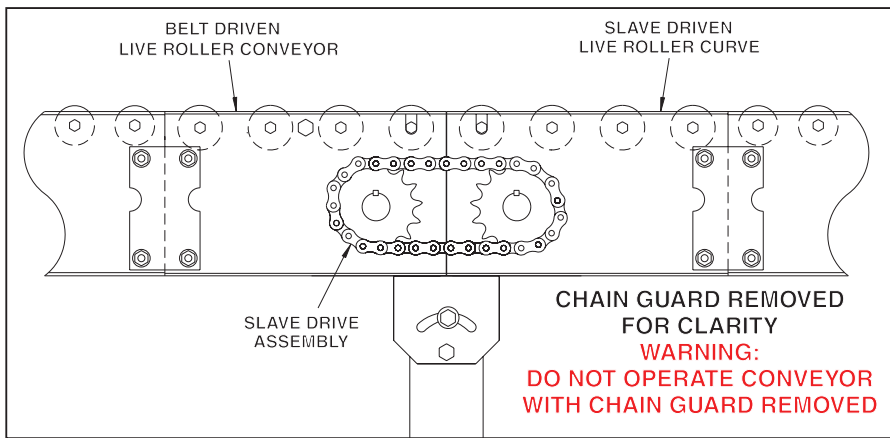

NOTE: There are two primary methods of installation for a curve-driven by its own gear motor or SLAVE driven from another conveyor.

Once conveyor is uncrated, installation of curve or spur may begin (note that in following text we will use "curve" for reference to both curves and curve spurs). Locate unit in the actual installation area.

There are two primary methods of installation for a curve-driven by its own gear motor or SLAVE driven from another conveyor. Most often, curves are SLAVE

driven by belt driven live rollers or slider bed belt conveyors, which eliminates gear motor drive assembly for curve.

Locate actual bed section of conveyor which is to slave drive curve to begin installation. Note that this conveyor is usually set up before curve is installed. Bed section labels are located on bed of driving conveyor showing where slave

driven curve will be installed (see illustration above). For curves not slave driven, location of installation in most usually noted by conveyor "mark numbers".

Use mechanical hoist (fork truck or other available means) to raise bed sections to approximate installed elevation. Locate supports, attach to curve and mate curve with butt couplings.

IDENTIFYING/INSTALLING PERMANENT FLOOR SUPPORTS

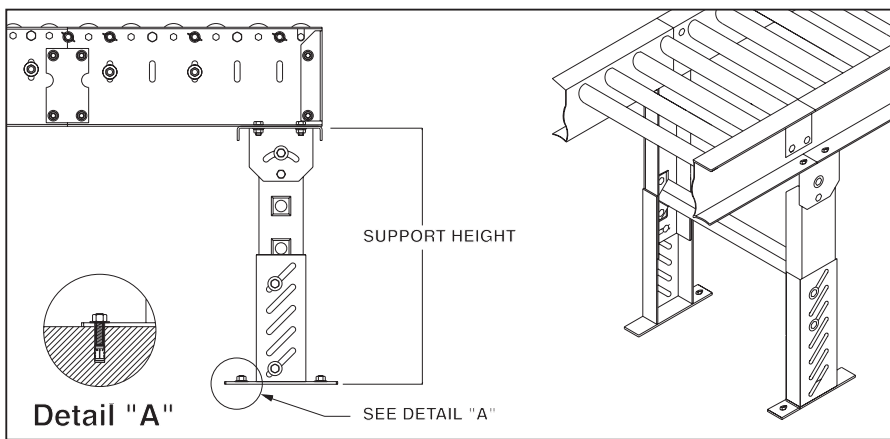

CAUTION: Always anchor permanent supports to floor (or mounting surface). Use 3/8" x 2-1/2" (or longer) wedge anchors for permanent installation in concrete flooring.

*MINIMUM SUPPORT HEIGHT							
MEDIUM DUTY			HEAVY DUTY				
SM-1	7-1/4"	SM-7	34-1/4"	SH-1	6-1/4"	SH-7	25-3/4"
SM-2	10-1/4"	SM-8	46-1/4"	SH-2	7-3/4"	SH-8	31-3/4"
SM-3	13-1/4"	SM-9	58-1/4"	SH-3	10-3/4"	SH-9	43-3/4"
SM-4	16-1/4"	SM-10	70-1/4"	SH-4	13-3/4"	SH-10	55-3/4"
SM-5	20-1/4"	SM-11	80-1/4"	SH-5	16-3/4"	SH-11	67-3/4"
SM-6	24-1/4"	SM-12	92-1/4"	SH-6	19-3/4"	SH-12	29-3/4"

It is most common to use single tier permanent floor supports at each end of a curve, for models 138LRC and 196LRC. In the center of the curve, a single leg support is required underneath the outside frame rail. If the frame rail consists of two or more frame rails and is joined together in the center of the curve, a full support is required.

For model 138LRCS and 196LRCS curve spurs, two supports are generally required, one support at the junction between the spur and the curve and one support at the tangent end of the curve.

Adjust elevation to top of conveyor by loosening bolts in support uprights, raising or lowering conveyor and fully tightening bolts at desired elevation. Tighten

all bolts in supports before unit operation. Complete support installation by lagging support attachment plates to floor with two lag bolts in a diagonal pattern in support foot plate mounting holes. Conveyor must be level across width of unit before completing final support height adj.

*Supports are normally shipped at minimum support height. See chart above.

CEILING HANGERS AND POLYTIER SUPPORTS

INSTALLATION OF CEILING HANGERS

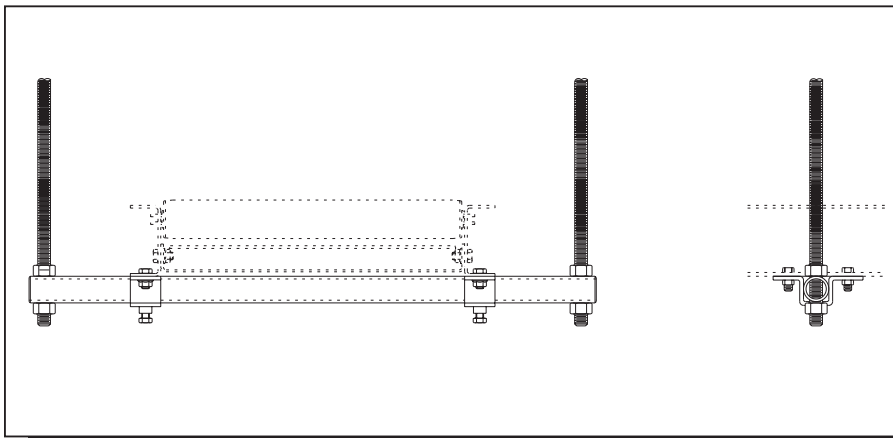

WARNING: It is the responsibility of the customer and installation personnel to supply and install net or mesh guarding on conveyors mounted overhead to prevent product and/or debris from falling to floor in areas where required.

Ceiling hangers are frequently used in high-elevation applications for suspension from ceiling. The 5/8" diameter (#11 UNC) all threaded rod is supplied to allow infinite vertical adjustment along the length of the suspension rod (see illustration above).

Attach and firmly tighten U-shaped retainer ("hat") bracket to underneath side of

lower conveyor flange with hardware provided to hold cross pipe (1" inside diameter) against underneath side of conveyor.

Do not tighten cross pipe locking bolts (these attach in the bottom of the U-shaped retainer bracket) until threaded suspension rods have been firmly secured to ceiling structure.

To adjust conveyor elevation, tighten or

loosen lower nut and jam nut on threaded suspension rods to desired elevation. A lock washer must be used on suspension rods to maintain unit at desired elevation.

When unit is at operating elevation and unit has been levelled across bed width, tighten locking bolts in U-shaped bracket to secure position of cross pipe.

INSTALLATION OF POLYTIER SUPPORTS

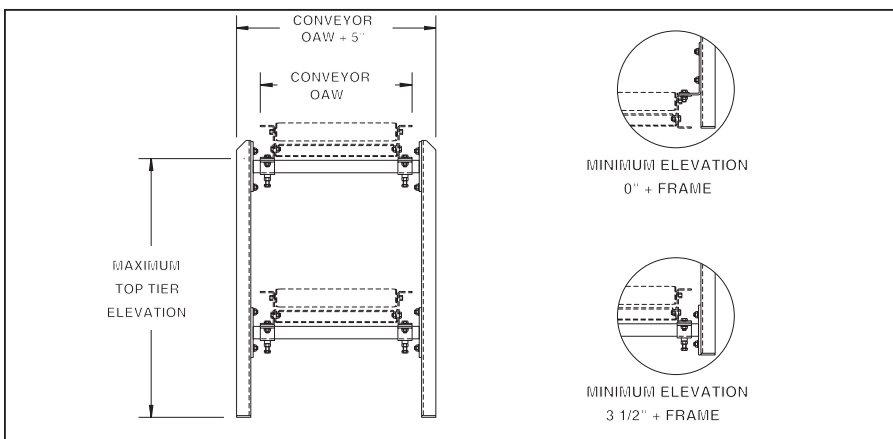

NOTE: To install, raise conveyor to desired elevation, place cross pipe underneath lower conveyor flange, attach cross pipe to upright legs and use U-shaped retainer ("hat") bracket to connect cross pipe to lower conveyor flange.

POLYTIER SUPPORT CHANNEL HEIGHT					
PSM-1	23"	PSM-6	53"	PSM-11	83"
PSM-2	29"	PSM-7	59"	PSM-12	89"
PSM-3	35"	PSM-8	65"	PSM-13	95"
PSM-4	41"	PSM-9	71"	PSM-14	101"
PSM-5	47"	PSM-10	77"	PSM-15	107"

Polytier supports provide convenient installation method for two or more tiers of conveyor. To install, raise conveyor to desired elevation (approximate). Place 1" inside diameter cross pipe underneath lower conveyor flange. Attach cross pipe to upright legs. Use U-shaped retainer ("hat") bracket to connect cross pipe to lower conveyor flange. Do not tighten fully at this time.

There are two styles of attachment brackets available for use with polytier supports. Minimum elevation style (see illustration above) offers lowest unit elevation, 0" + depth of frame utilizing L-shaped mounting bracket. Standard elevation style offers unit elevation of 3-1/2" + depth of frame and includes bracket welded to cross pipe which is bolted to upright legs during installation.

When unit is at operating elevation and unit has been checked across width for level, tighten locking bolts in U-shaped bracket. Add knee braces for unit rigidity.

*NOTE: Overall conveyor height is dictated by type of drive assembly used-i.e. underneath, center drive, side mount, etc.

INSTALLATION OF BELTING

V-BELT CONNECTIONS

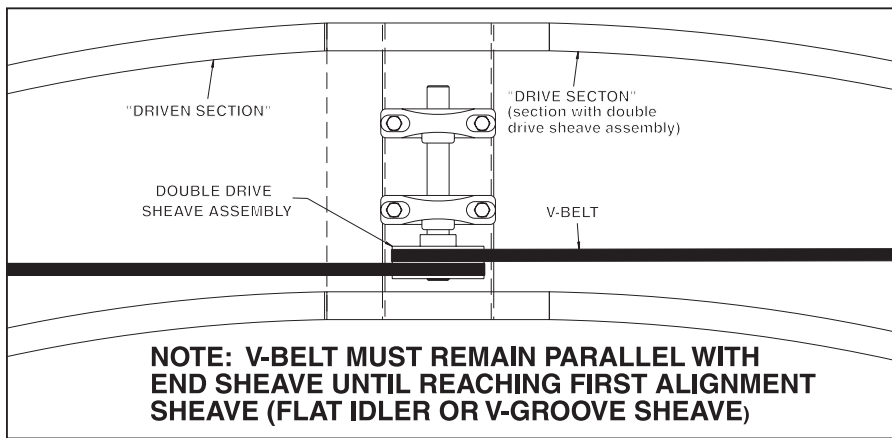

WARNING: Safety finger guards are located above V-belt on all live roller curves and spurs. Removal of finger guard assemblies may result in serious injury to personnel stationed near or coming in contact with conveyor. V-belt must be kept in good condition and belt tension must be properly adjusted for safe work environment. **BEFORE ANY ADJUSTMENTS ARE ATTEMPTED, SHUT "OFF" AND LOCK OUT POWER SOURCE.**

In some applications (180 degree, long straight tangents, etc.), curves are manufactured in two or more sections requiring the use of more than a single drive belt. Although set up and test run (and, subjected to quality control inspection) at the factory, unit may require disassembly for shipping. In such cases, V-belt must be re-connected before operation.

To reconnect belts, determine curve section containing double sheave drive assembly, or "drive section" in illustration above. This drive section features drive V-belt shipped mounted as required. The V-belt on the adjoining curve section, or "driven section", must be attached to double sheave drive assembly. To install, loosen V-belt take-up sheave on driven section to allow adequate slack in V-belt for attachment to double sheave. Then,

complete V-belt assembly by properly adjusting take-up sheave in center of driven section as outlined in following section.

NOTE: Depending on the model or BF of curve or spur, there are several take-up configurations available. See page 9 of manual for more information.

ADJUSTING V-BELT TENSION

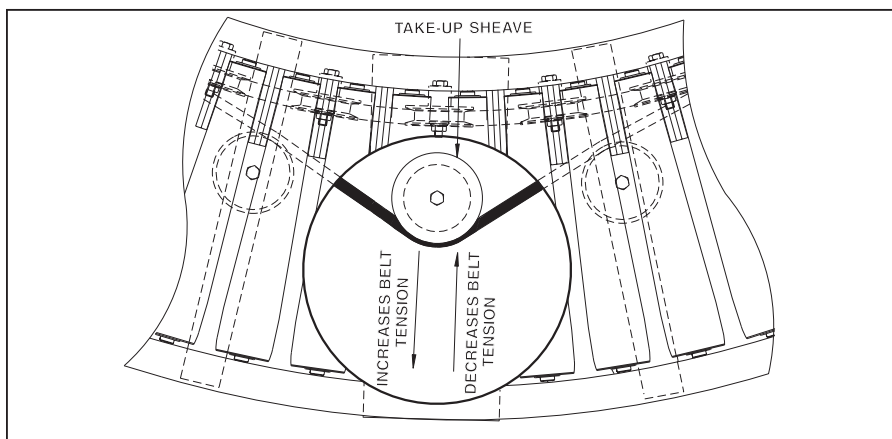

WARNING: Safety finger guards are located above V-belt on all live roller curves and spurs. Removal of finger guard assemblies may result in serious injury to personnel stationed near or coming in contact with conveyor. V-belt must be kept in good condition and belt tension must be properly adjusted for safe work environment. **BEFORE ANY ADJUSTMENTS ARE ATTEMPTED, SHUT "OFF" AND LOCK OUT POWER SOURCE.**

Maintaining proper belt tension is vital to proper unit operation and long V-belt life. Over-tensioning drive belt requires more horsepower, decreases belt life and may harm unit drive and take-up sheaves.

To increase drive belt tension (or, to take up slack in V-belt), move take-up sheave toward outside of curve (or spur) by adjusting take-up rod on take-up sheave

(see illustration above). Be careful not to over-tension belt.

To "decrease" belt tension, move take-up sheave toward inside of curve (or spur) by adjusting take-up rod on take-up sheave. When adjustment is complete, tighten jam nut to complete tensioning procedure. Make adjustments to drive belt in small increments.

For adjusting drive pressure applied to V-belt from drive sheaves, see next section.

NOTE: When adjusting V-belt tension, V-belt must remain parallel with end sheave until reaching first alignment sheave (sheave may be flat idler or V-grooved).

INSTALLATION OF BELTING

V-BELT DRIVE PRESSURE ADJUSTMENT

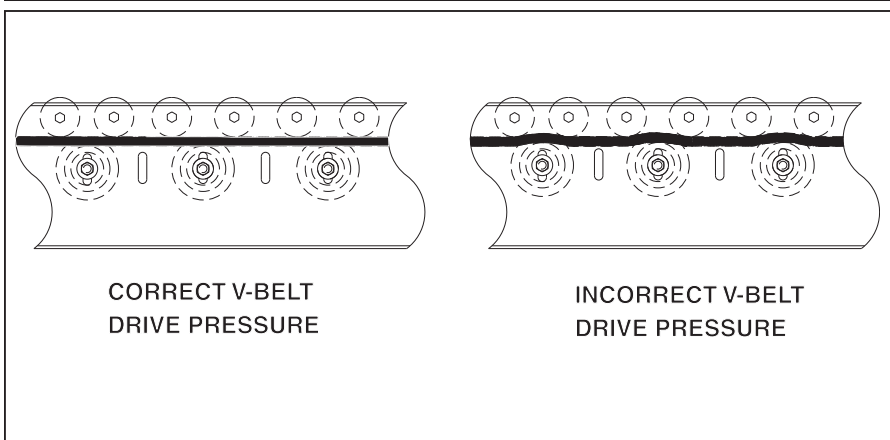

WARNING: Safety finger guards are located above V-belt on all live roller curves and spurs. Removal of finger guard assemblies may result in serious injury to personnel stationed near or coming in contact with conveyor. V-belt must be kept in good condition and belt tension must be properly adjusted for safe work environment. **BEFORE ANY ADJUSTMENTS ARE ATTEMPTED, SHUT "OFF" AND LOCK OUT POWER SOURCE.**

Maintaining proper drive belt pressure is vital to proper unit operation and long V-belt life. Over-applying drive belt pressure requires more horsepower and may harm unit drive and take-up components. Belt life is drastically reduced when unit is operated with incorrect drive belt pressure.

Belt driven live roller curves and spurs

require adequate drive pressure on the drive belt to convey the heaviest unit load. Therefore, if curve or spur does not properly convey the heaviest unit load, adjust the drive belt pressure as outlined below.

To increase drive belt pressure, move sheave "up" (see above illustration) toward roller. To decrease drive belt

pressure, lower sheave away from roller. Make adjustments in small increments. **DO NOT** place too much drive pressure on sheaves.

In worst conditions, conveyor may stall, thus causing motor to overheat and untimely unit shut down, when drive sheaves have been raised too high.

REPLACING V-BELT AND SHEAVES

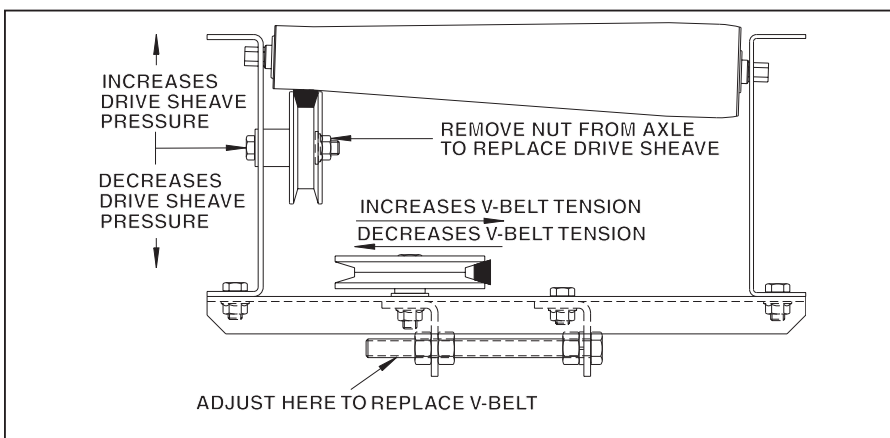

WARNING: Safety finger guards are located above V-belt on all live roller curves and spurs. Removal of finger guard assemblies may result in serious injury to personnel stationed near or coming in contact with conveyor. V-belt must be kept in good condition and belt tension must be properly adjusted for safe work environment. **BEFORE ANY ADJUSTMENTS ARE ATTEMPTED, SHUT "OFF" AND LOCK OUT POWER SOURCE.**

As outlined in previous sections, the importance of properly setting drive tension and drive pressure on V-belts simply cannot be overstated. When V-belt or drive sheaves are out of adjustment, life of sheaves and V-belt may be drastically reduced, thus requiring untimely replacement(s).

Before ANY maintenance operations are performed on belt driven live roller curves

or spurs, it is VITAL that ALL conveyors are shut "OFF" and power source is locked out. Confirm that power source has been locked out before beginning maintenance.

For replacing V-belt, remove conveyor tread rollers, loosen take-up assembly as previously noted and remove belt. Use old belt to identify replacement, which is readily available from Roach or may be

purchased locally to expedite replacement procedure. Install new belt, tread rollers and re-set belt tension.

Should any drive sheaves require replacement, consult Roach distributor for new sheaves. Remove nut from drive sheave axle, remove worn sheave and replace with new unit. Replace nut and set drive sheave pressure as previously outlined.

V-BELT PATHS

V-BELT PATH FOR SPURS AND CURVES

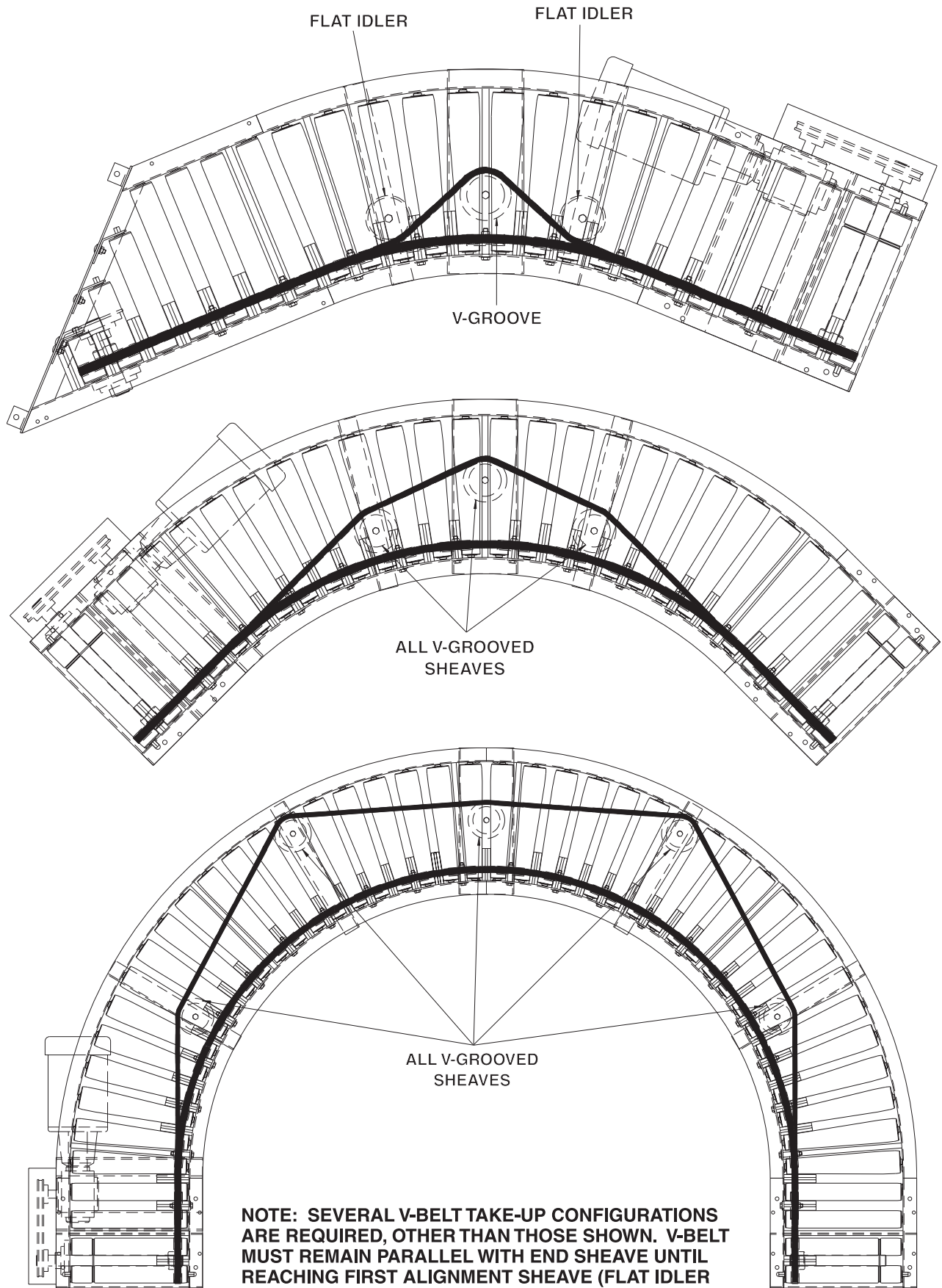

NOTE: SEVERAL V-BELT TAKE-UP CONFIGURATIONS ARE REQUIRED, OTHER THAN THOSE SHOWN. V-BELT MUST REMAIN PARALLEL WITH END SHEAVE UNTIL REACHING FIRST ALIGNMENT SHEAVE (FLAT IDLER OR V-GROOVE SHEAVE).

START-UP PROCEDURES

DRIVE CHAIN AND SPROCKET ALIGNMENT

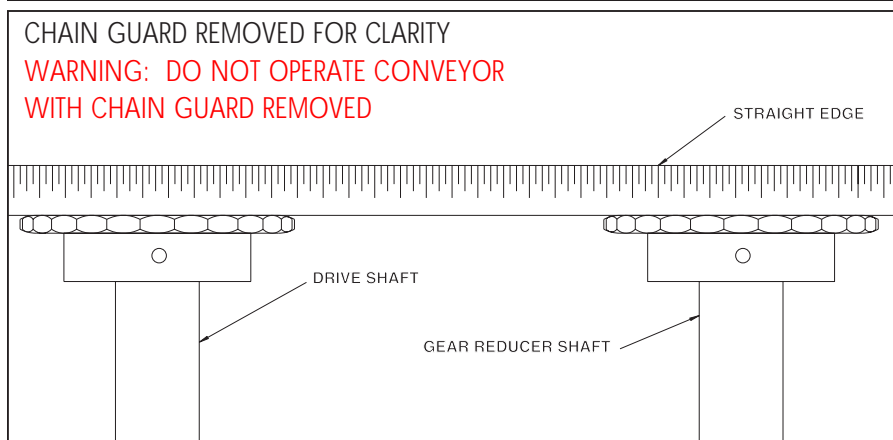

WARNING: To check drive sprocket alignment, it is imperative that conveyor is shut "OFF" and power source is locked out before any adjustments are attempted.

Set up and maintenance of drive sprocket and drive chain alignment is critical (on curves or spurs with drive assembly). A periodic visual inspection is recommended to confirm alignment of drive components (which includes both drive sprockets and drive chain). Should set screws become loose, drive sprockets are subject to

excessive wear and ultimately, to untimely replacement.

To check drive sprocket alignment, it is imperative that conveyor is shut "OFF" and power source is locked out before any adjustments are attempted. Remove chain guard cover and place straight-edge (see illustration above) across face of

both drive sprockets. If re-alignment is necessary, loosen set screws and adjust drive sprockets as required. Remember to securely tighten set screws when alignment is complete.

Before replacing chain guard cover, check drive chain tension as described in following section, "Drive Chain and Sprocket Tension."

DRIVE CHAIN AND SPROCKET TENSION

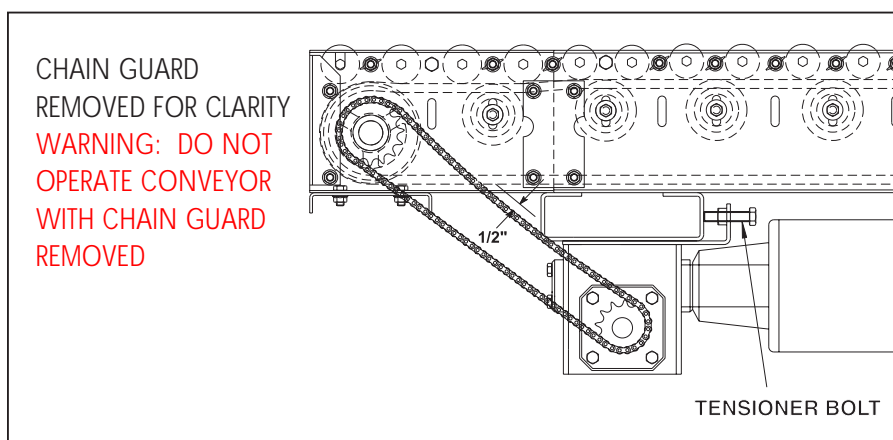

WARNING: To check drive sprocket tension, shut "OFF" and lock out power source before any adjustments are attempted.

Maintaining proper chain tension is especially important. Again, a periodic visual inspection is recommended to ensure chain tension within a pre-determined operating range.

Remember, before any adjustments are attempted, conveyor must be shut "OFF" and power source locked out.

Before replacing chain guard cover, check

to see if drive chain is operating within 1/2" range (see above illustration). If unit is out of tolerance, adjustment is necessary.

To adjust drive chain tension, tensioner bolt located on reducer push plate should be tightened (rotate clockwise) if chain tension is loose. Tighten until proper operating range is achieved. If chain tension is too

tight, loosen tensioner bolt (rotate counter-clockwise) as required. When adjustment is complete replace chain guard cover.

WARNING: Do not operate unit until chain guard cover is replaced. Serious operator or other personal injury could result if protective guarding is not replaced.

START-UP PROCEDURES

GEAR REDUCER VENT PLUG

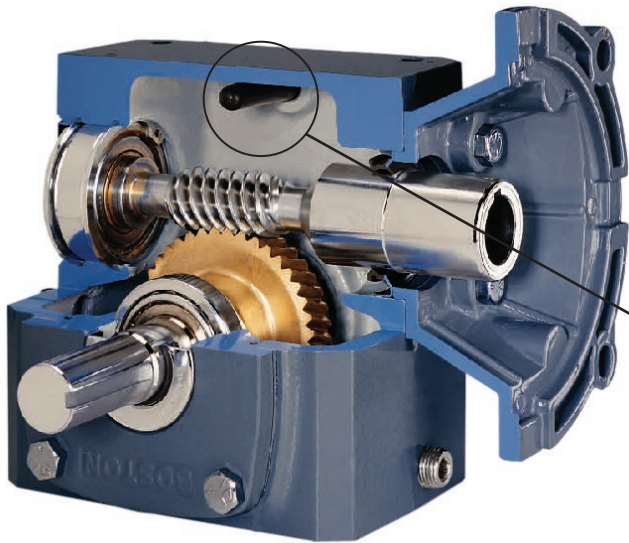

NOTE
The gear reducer is supplied with a "PosiVent®". No vent plugs are required.

PosiVent Unique design incorporates a single seam construction. Factory filled with synthetic lubrication for universal mounting. Lubed for life, no oil changes are required.

To expedite the installation and start-up process, all gear reducers are shipped filled with oil. The reducers are sealed and lubed for life and require no oil changes.

PREPARING FOR INITIAL START-UP



⚠ DANGER
WARN ALL PERSONNEL TO KEEP CLEAR OF CONVEYOR DURING UNIT START-UP
Electrical controls must be designed by a qualified electrical engineer to ensure that appropriate safety features (emergency stops, pull cords, switches, etc.) are installed on unit for safe operation. Before conveyor start-up, all operators and other personnel coming in contact with unit must be properly trained and must have read accompanying Tech Handbook.

Before conveyor start-up, all operators and other personnel coming in contact with unit must be properly trained and must have read accompanying Tech Handbook.

Provisions must be in order to instruct all personnel coming in contact with conveyor on the location of emergency stops, pull cords, etc.

A routine maintenance program should

be implemented before unit is placed into operation so that fundamental unit components are attended to. This maintenance program should include an inspection to ensure that any dangerous or hazardous operating conditions are noted and IMMEDIATELY corrected, as well as including electrical and mechanical unit inspections and corrections.

Finally, when conveyor is initially started, an immediate visual inspection should include motor, gear reducer, belt tracking (discussed in following section under "Belt Tracking") and related adjustments noted in handbook for unit/component corrections.

MAINTENANCE SAFETY PRECAUTIONS BEFORE PERFORMING MAINTENANCE

CAUTION: Only trained personnel shall perform maintenance functions. Before maintenance operations are performed, conveyor must be shut "OFF" and disconnects locked in the "OFF" position to prevent unit from unauthorized start-up.

One of the most important guidelines for maximizing conveyor operation and personnel safety is to implement a regular maintenance schedule and train personnel on the appropriate needs of the specific unit.

Only trained personnel shall perform maintenance functions. Before maintenance operations are performed, conveyor must be shut "OFF" and disconnects locked in the "OFF" position to prevent unit from unauthorized start-up during maintenance. All personnel should be informed of the safety procedures associated with unit maintenance and performance.

Do not perform any work on conveyors or conveyor system while in operation unless it is impossible to otherwise conduct adjustment, lubrication or other maintenance function. Only experienced, trained personnel possessing advanced hazards-training should attempt such critical operations.

MAINTENANCE AND FOLLOW-UP DETAILS

CAUTION: Only trained personnel shall perform maintenance functions. When maintenance is completed, only authorized personnel shall be permitted to start conveyor following maintenance or other emergency shut-off.

While performing maintenance do not wear loose clothing. Immediately report any hazardous conditions—sharp edges, pinch (or nip) points or other conditions that may result when several manufacturers supply machinery which may create operating hazards.

When using mechanical aids such as hoists, cables, or cranes exercise extreme caution to prevent damage to conveyors or other integrated machinery which may create a working hazard when maintenance is completed and units are in operation.

Clean up any spilled lubricants or other materials used in the maintenance process or those which may be deposited during unit operation. Eliminating poor housekeeping practices increases unit efficiency while creating safer personnel working conditions.

After maintenance, conduct visual inspection to ensure that all safety devices and guards have been replaced. Confirm that all

units are clear of tools, debris or other items. Before starting conveyor, check condition of unit caution labels (see "CAUTION LABELS" at front of handbook). If labels have been destroyed or are not clearly legible, call 870.483.7631 to receive replacement labels. Placement of caution labels is critical to avoid unauthorized unit operation which may result in hazardous working conditions for all related personnel coming in contact with conveyor.

Warn personnel that conveyor is being prepared for start-up and to stay clear of unit. Do not start conveyor until all personnel are clear. When maintenance is completed, only authorized personnel shall be permitted to start conveyor following maintenance or other emergency shut-off.

MAINTENANCE AND LUBRICATION

PERIODIC MAINTENANCE SCHEDULE

MODEL NO. _____

WEEKLY RECOMMENDED MAINTENANCE SCHEDULE *	
COMPONENT	DETAIL OF MAINTENANCE
V-Belt	Inspect belt tension and sheave drive pressure applied to V-Belt.
V-Belt Pressure Sheaves	Check & re-tighten axles. Check for overall wear.
Pillow Block/Flange Bearings	Lubricate in dirty, dusty or moist/wet conditions.
Unit Safety Check	Confirm placement of all guards including safety finger guards, pop-out rollers, warning labels. Check for loose bolts, nip points & other hazards.

MONTHLY RECOMMENDED MAINTENANCE SCHEDULE *	
COMPONENT	DETAIL OF MAINTENANCE
Gear Reducer	Check for leaks.
Drive Chain	Check for proper operating tension & for overall wear & lubricate.
Drive Sprockets	Check for overall wear & re-tighten set screws.
V-Belt Drive Belt	Check for proper operating tension & overall wear.
Drive Sheaves	Check & re-tighten set screws & check for overall wear.
Pillow Block/Flange Bearings	Lubricate (normal conditions)

PERIODIC RECOMMENDED MAINTENANCE SCHEDULE *	
COMPONENT	DETAIL OF MAINTENANCE
Gear Reducer	Check for leaks.
Drive Chain	Clean (brush in solvent) & re-lubricate by applying lubricant to inside of chain with brush or spout can at 2000 hour intervals.
Motor	Check & clear motor ventilation openings at 500 hour intervals Check miscellaneous operating conditions (normal heat & noise).

*All charts are for guidelines in normal operating or 'as noted' conditions. Severe applications may warrant additional maintenance.

TROUBLE SHOOTING / SERIAL PLATE

TROUBLE SHOOTING		
TROUBLE	PROBABLE CAUSE	REMEDY
Motor & gear reducer running excessively hot, or hard to start	A. Drag on conveyor B. Lack of lubricant C. Frozen sprocket D. Frozen roller E. Overload F. Electrical	A. Inspect entire conveyor for obstruction causing drag on chain. B. Check for leaks. C. Check and inspect all sprockets and bearings. Replace sprockets failing to rotate or that are difficult to rotate. D. Check all rollers for rotation. E. Reduce cause and/or increase motor horsepower. F. Check wiring and circuits, take ampere reading, replace motor if necessary.
Motor & gear reducer makes excessive noise	A. Lack of lubrication B. Damaged Gears C. Faulty Bearing	A. Check for leaks. B. Replace unit. C. Replace bearing.
Drive chain, conveying chain or sprockets experience excessive wear	A. Excessive chain tension B. Sprockets misaligned C. Chain not lubricated D. Damaged sprocket or chain E. Misalignment of chain guard F. Dirty chain	A. Reduce chain tension. B. Realign with straight edge across sprocket faces. C. Lubricated chain with approved lubricant, wipe away excess lubricant. D. Replace Damaged Component. E. Adjust chain guard assembly as necessary. F. Clean thoroughly and lubricate with approved lubricant.
Drive chain, conveying chain or sprockets make excessive noise	A. Insufficient chain tension B. Chain not adequately lubricated C. Sprockets misaligned	A. Adjust chain tension. B. Lubricate chain with approved lubricant, wipe away excess lubricant. C. Realign sprockets with straight edge across sprocket faces.
Pulsating chain	A. Insufficient chain tension B. Misalignment of chain guard C. Overload	A. Adjust chain tension. B. Adjust chain guard assembly as necessary. C. Inspect for obstruction to or drag on conveyor.
Broken chain	A. Frozen bearing or sprocket shaft B. Worn or damaged chain C. Obstructed or jam	A. Inspect for damaged bearings, replace if necessary. Replace links as required. B. Replace chain as required. C. Remove obstruction to clear jam.
Sprocket loose on shaft	A. Loose set screws B. Worn or damaged key	A. Realign sprockets with straight edge and tighten set screws. B. Replace with new key.
Excessive slack in chain	A. Normal wear	A. Expect rapid chain growth in first two weeks of operation. B. Adjust chain tension as specified in the manual.



ORDERING REPLACEMENT PARTS

To order any replacement parts or when calling for assistance with any powered conveyor, ALWAYS provide unit serial number. Shown at actual size, this

aluminum plate is placed on the conveyor frame near the location of the drive assembly.

To order replacement parts or add-on components, contact the Roach distributor who originally furnished the unit if possible. If this is not possible, contact the National Sales Office at 870-483-7631 for the name of the authorized Roach distributor in your area. Have unit model number and serial number BEFORE calling. Refer to unit drawings (in rear section of handbook) for part numbers if ordering replacement parts.

MODEL 138LRC

PARTS LIST FOR UNIT WITH END DRIVE / SIDE MOUNT END DRIVE

ITEM #	DESCRIPTION	ITEM #	DESCRIPTION
1	138G roller w/5/16" shaft	35	5/16" flat washer
2	138T tapered roller	36	3/8" flange nut
3	138G grooved roller w/5/16" hex shaft	37	3/8" flat washer
4	Take-up sheave mounting channel	38	7/16" lock washer
5	45°/90° inside curve channel	39	1/2" hex nut
6	Splice plate	40	1/2" lock washer
7	Bolt-in butt coupling, left hand	41	1/2" flange nut
8	Bolt-in butt coupling, right hand	42	1/2" flat washer
9	Pillow block mounting bracket	43	Orange nylon finger guard
10	Take-up rod support angle	44	Black nylon sheave spacer/adaptor
11	Sheave mounting channel	45	V-belt sheave w/1-3/16" bore
12	Idler sheave angle	46	Nylon 3" O.D. V-groove sheave
13	Left hand outside tangent drive channel	47	Steel 4" O.D. V-groove take-up sheave
14	Right hand outside tangent drive channel	48	V-belt
15	Left hand inside tangent side channel	49	Drive band
16	Right hand inside tangent side channel	50	Motor
17	Take-up mounting angle	51	Gear reducer
18	45°/90° outside curve channel	52	Drive sprocket
19	Tail sheave shaft	53	Gear reducer drive sprocket
20	Drive sheave shaft	54	#50 (thru 1-1/2 HP) ir #60 roller chain
21	Bed spacer rod	55	Chain guard angle mount (Not shown)
22	3 hole flange bearing w/1-3/16" bore	56	Reducer push plate assembly
23	Pillow block bearing w/1-3/16" bore	57	Underneath motor base plate
24	3/8" x 3/4" HHCS	58	End drive chain guard assembly
25	3/8" x 1-1/4" HHCS		
26	3/8" x 1-1/2" HHCS		OPTIONAL SIDE MOUNT END DRIVE PARTS LIST
27	3/8" x 1-3/4" HHCS	50	Motor
28	3/8" x 2-1/4" HHCS	51	Gear reducer
29	7/16" x 1" HHCS	52	Drive sprocket
30	1/2" x 1-1/2" HHCS	53	Gear reducer drive sprocket
31	1/2" x 6" HHTB	54	#50 (thru 1-1/2 HP) ir #60 roller chain
32	5/16" x 3/4" carriage bolt	55	Reducer push plate assembly
33	3/8" x 3/4" carriage bolt	56	Side mount motor base plate
34	5/16" flange nut	57	Side mount chain guard assembly

Specify Unit Serial Number when ordering replacement parts to ensure proper allocation of components (See Ordering Replacement Parts on page 15).

Recommended Spare Parts are shown in red. Charted are item numbers and part descriptions.

When ordering use example below.

Example: Need a replacement 138T tapered roller for 138LRC

Part No: SN 123456 - 2 - 138T tapered roller



ILLUSTRATIONS FOR UNIT WITH END DRIVE / SIDE MOUNT END DRIVE

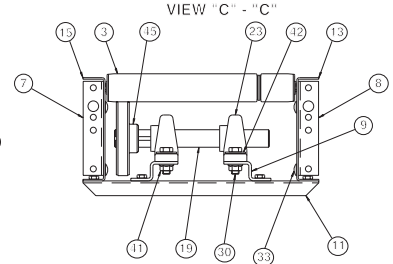
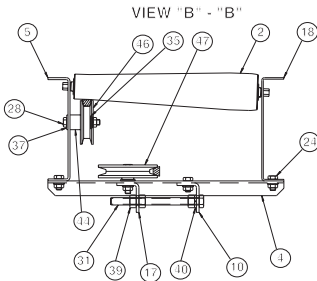
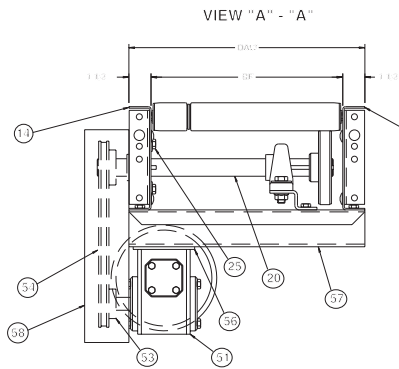
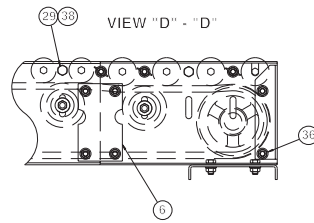
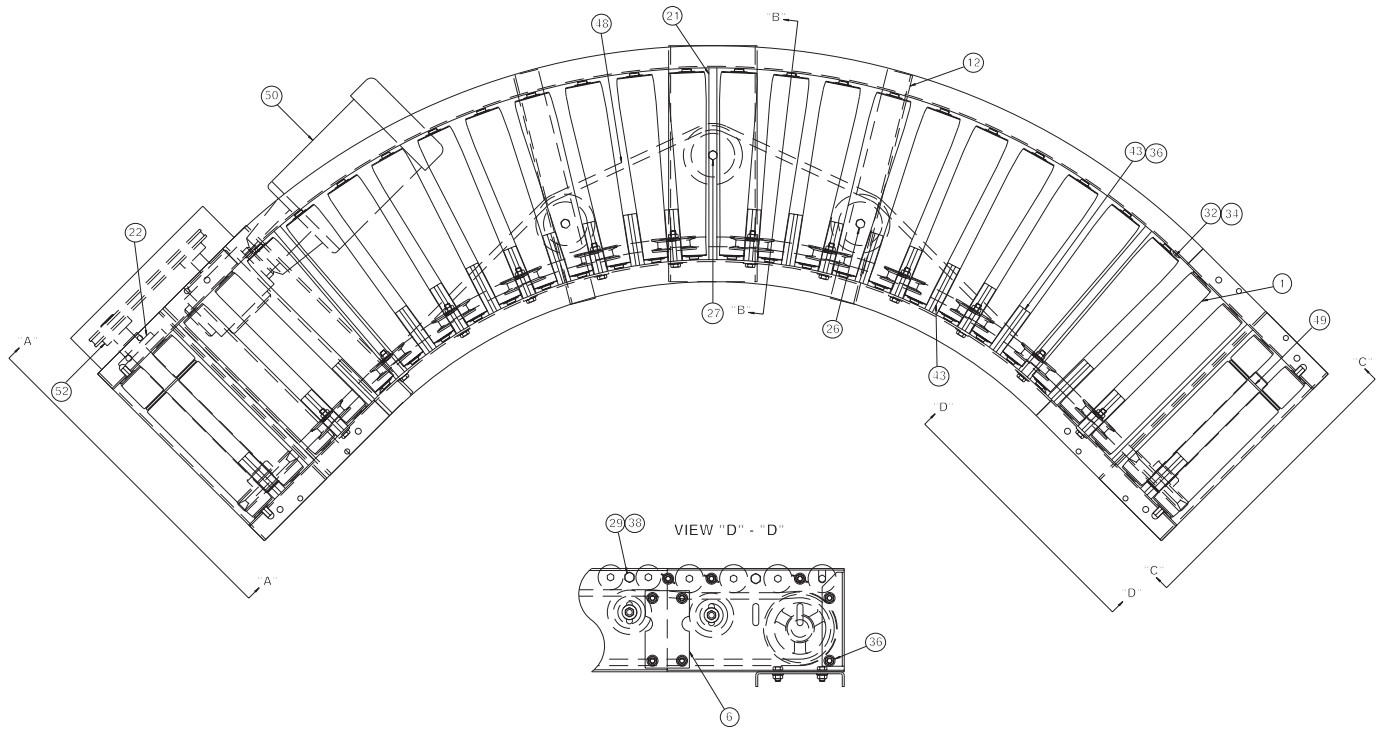

OPTIONAL SIDE MOUNT END DRIVE

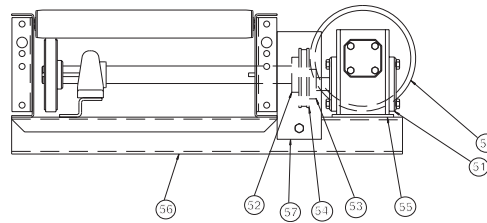

MODEL 196LRC

PARTS LIST FOR UNIT WITH END DRIVE / SIDE MOUNT END DRIVE

ITEM #	DESCRIPTION	ITEM #	DESCRIPTION
1	196S roller	35	5/16" flat washer
2	254T tapered roller	36	3/8" flange nut
3	196S grooved roller	37	3/8" flat washer
4	Take-up sheave mounting channel	38	7/16" lock washer
5	45°/90° inside curve channel	39	1/2" hex nut
6	Splice plate	40	1/2" lock washer
7	Bolt-in butt coupling, left hand	41	1/2" flange nut
8	Bolt-in butt coupling, right hand	42	1/2" flat washer
9	Pillow block mounting bracket	43	Orange nylon finger guard
10	Take-up rod support angle	44	Black nylon sheave spacer/adaptor
11	Sheave mounting channel	45	V-belt sheave w/1-3/16" bore
12	Idler sheave angle	46	Nylon 3" O.D. V-groove sheave
13	Left hand outside tangent drive channel	47	Steel 4" O.D. V-groove take-up sheave
14	Right hand outside tangent drive channel	48	V-belt
15	Left hand inside tangent side channel	49	1/8" Dia. x 9-1/2" lg. Drive band
16	Right hand inside tangent side channel	50	Motor
17	Take-up mounting angle	51	Gear reducer
18	45°/90° outside curve channel	52	Drive sprocket
19	Tail sheave shaft	53	Gear reducer drive sprocket
20	Drive sheave shaft	54	#50 (thru 1-1/2 HP) ir #60 roller chain
21	Bed spacer rod	55	Chain guard angle mount (Not shown)
22	3 hole flange bearing w/1-3/16" bore	56	Reducer push plate assembly
23	Pillow block bearing w/1-3/16" bore	57	Underneath motor base plate
24	3/8" x 3/4" HHCS	58	End drive chain guard assembly
25	3/8" x 1-1/4" HHCS		
26	3/8" x 1-1/2" HHCS		OPTIONAL SIDE MOUNT END DRIVE PARTS LIST
27	3/8" x 1-3/4" HHCS	50	Motor
28	3/8" x 2-1/4" HHCS	51	Gear reducer
29	7/16" x 1" HHCS	52	Drive sprocket
30	1/2" x 1-1/2" HHCS	53	Gear reducer drive sprocket
31	1/2" x 6" HHTB	54	#50 (thru 1-1/2 HP) ir #60 roller chain
32	5/16" x 3/4" carriage bolt	55	Reducer push plate assembly
33	3/8" x 3/4" carriage bolt	56	Side mount motor base plate
34	5/16" flange nut	57	Side mount chain guard assembly

Specify Unit Serial Number when ordering replacement parts to ensure proper allocation of components (See Ordering Replacement Parts on page 15).

Recommended Spare Parts are shown in red. Charted are item numbers and part descriptions.

When ordering use example below.

Example: Need a replacement 254T tapered roller for 196LRC

Part No: SN 123456 - 2 - 254T tapered roller



ILLUSTRATIONS FOR UNIT WITH END DRIVE / SIDE MOUNT END DRIVE

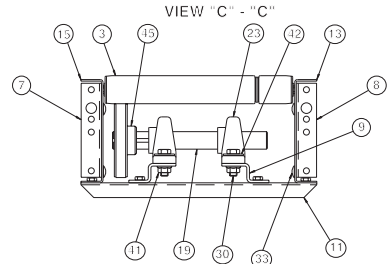
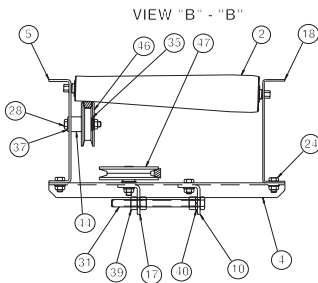
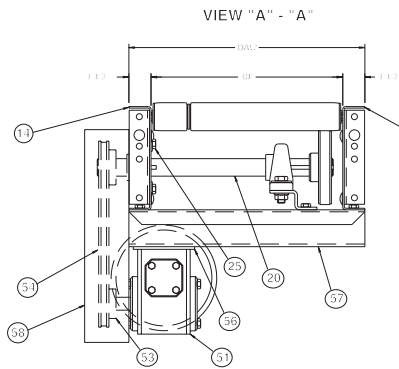
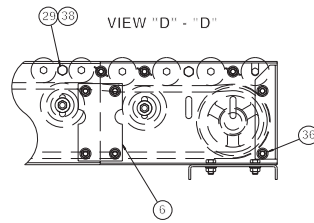
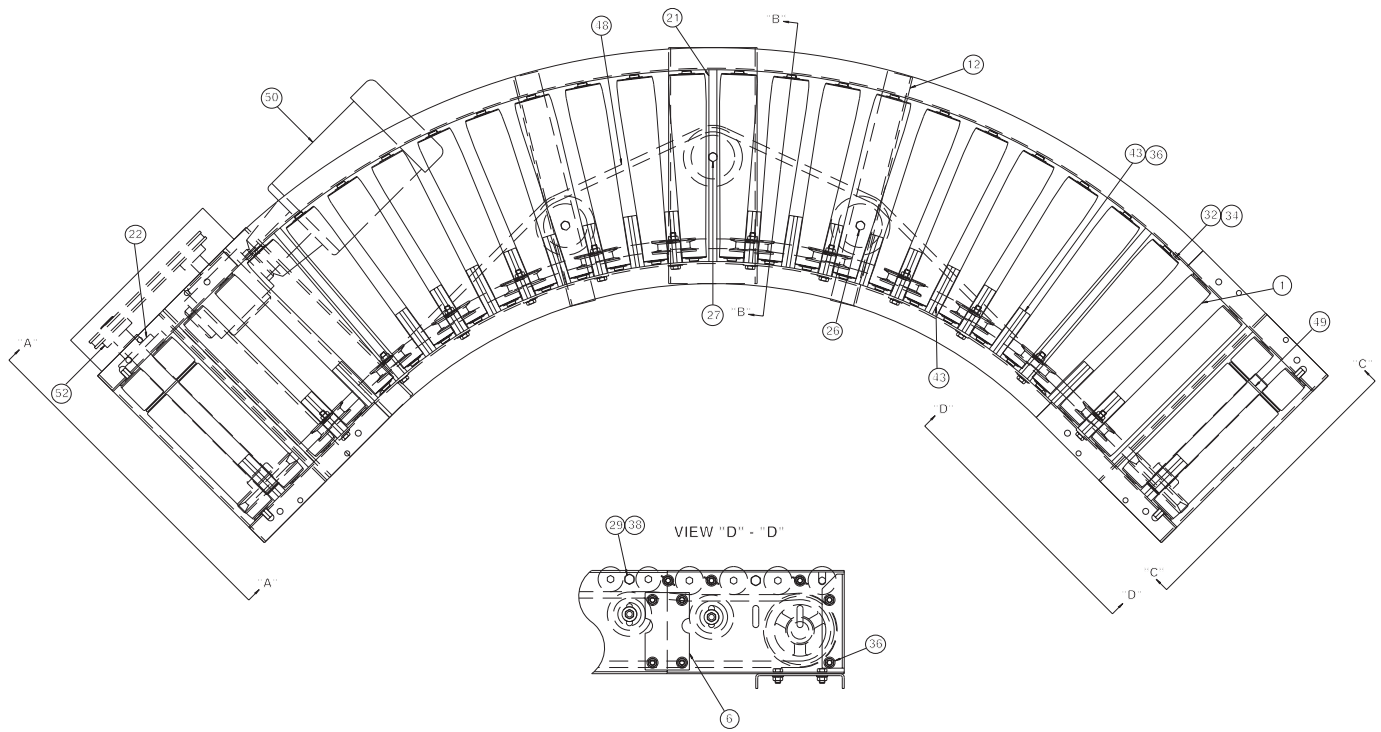

OPTIONAL SIDE MOUNT END DRIVE

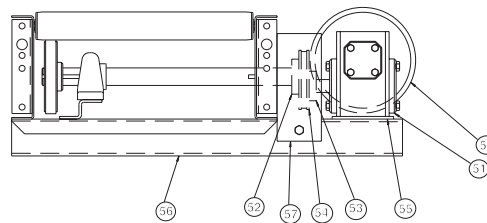

MODEL 138LRCS

PARTS LIST FOR UNIT WITH END DRIVE / SIDE MOUNT END DRIVE

ITEM #	DESCRIPTION	ITEM #	DESCRIPTION
1	138G roller w/5/16" hex (shortened for spur)	38	5/16" flange nut
2	138G roller w/5/16" hex	39	5/16" flat washer
3	138T tapered roller	40	3/8" flange nut
4	Spur assembly (specify 30° or 40°)	41	3/8" flat washer
5	138G grooved roller	42	7/16" lock washer
6	138G pinned roller w/5/16" hex (shortened for spur)	43	1/2" hex nut
7	Take-up sheave mounting channel	44	1/2" lock washer
8	Splice plate	45	1/2" flange nut
9	Bolt-in butt coupling (left hand)	46	1/8" x 1" cotter pin
10	Bolt-in butt coupling (right hand)	47	1/2" flat washer
11	Pillow block mounting bracket	48	Orange nylon finger guard
12	Take-up rod support angle	49	Black nylon sheave spacer/adaptor
13	Sheave mounting channel	50	V-belt sheave w/1-3/16" bore
14	Flange bearing mount	51	Flat idler sheave
15	Spur mounting bracket	52	Nylon 3" O.D. V-groove take-up sheave
16	32-1/2" IR inside curve channel 45°/60°	53	Steel 4" O.D. V-groove take-up sheave
17	Idler sheave angle	54	V-Belt
18	Outside tangent drive side channel	55	Drive band
19	Inside tangent side channel	56	Motor
20	Take-up mounting angle	57	Gear reducer
21	32-1/2" IR outside curve channel 45°/60°	58	Drive sprocket
22	Roller mounting clip	59	Gear reducer drive sprocket
23	Drive sheave shaft	60	#50 (thru 1-1/2 HP) or #60 roller chain
24	Tail sheave shaft	61	Chain guard angle mount (not shown)
25	Bed spacer rod	62	Reducer push plate assembly
26	3 hole flange bearing w/1-3/16" bore	63	Underneath motor base plate
27	Pillow block bearing w/1-3/16" bore	64	End Drive Chain Guard Assembly
28	3/8" x 3/4" HHCS		
29	3/8" X 1-1/4" HHCS		OPTIONAL SIDE MOUNT END DRIVE PARTS LIST
30	3/8" X 1-1/2" HHCS	56	Motor
31	3/8" X 1-3/4" HHCS	57	Gear reducer
32	3/8" X 2-1/4" HHCS	58	Drive sprocket
33	7/16" X 1" HHCS	59	Gear reducer drive sprocket
34	1/2" X 1-1/2" HHCS	60	#50 (thru 1-1/2 HP) or #60 roller chain
35	1/2" X 6" HHTB	61	Reducer push plate assembly
36	5/16" X 3/4" carriage bolt	62	Side mount motor base plate
37	3/8" X 3/4" carriage bolt	63	Side mount chain guard assembly

Specify Unit Serial Number when ordering replacement parts to ensure proper allocation of components (See Ordering Replacement Parts on page 15).

Recommended Spare Parts are shown in red. Charted are item numbers and part descriptions. When ordering use example below.

Example: Need a replacement 138T tapered roller for 138LRCS

Part No: SN 123456 - 3 - 138T tapered roller



ILLUSTRATIONS FOR UNIT WITH END DRIVE / SIDE MOUNT END DRIVE

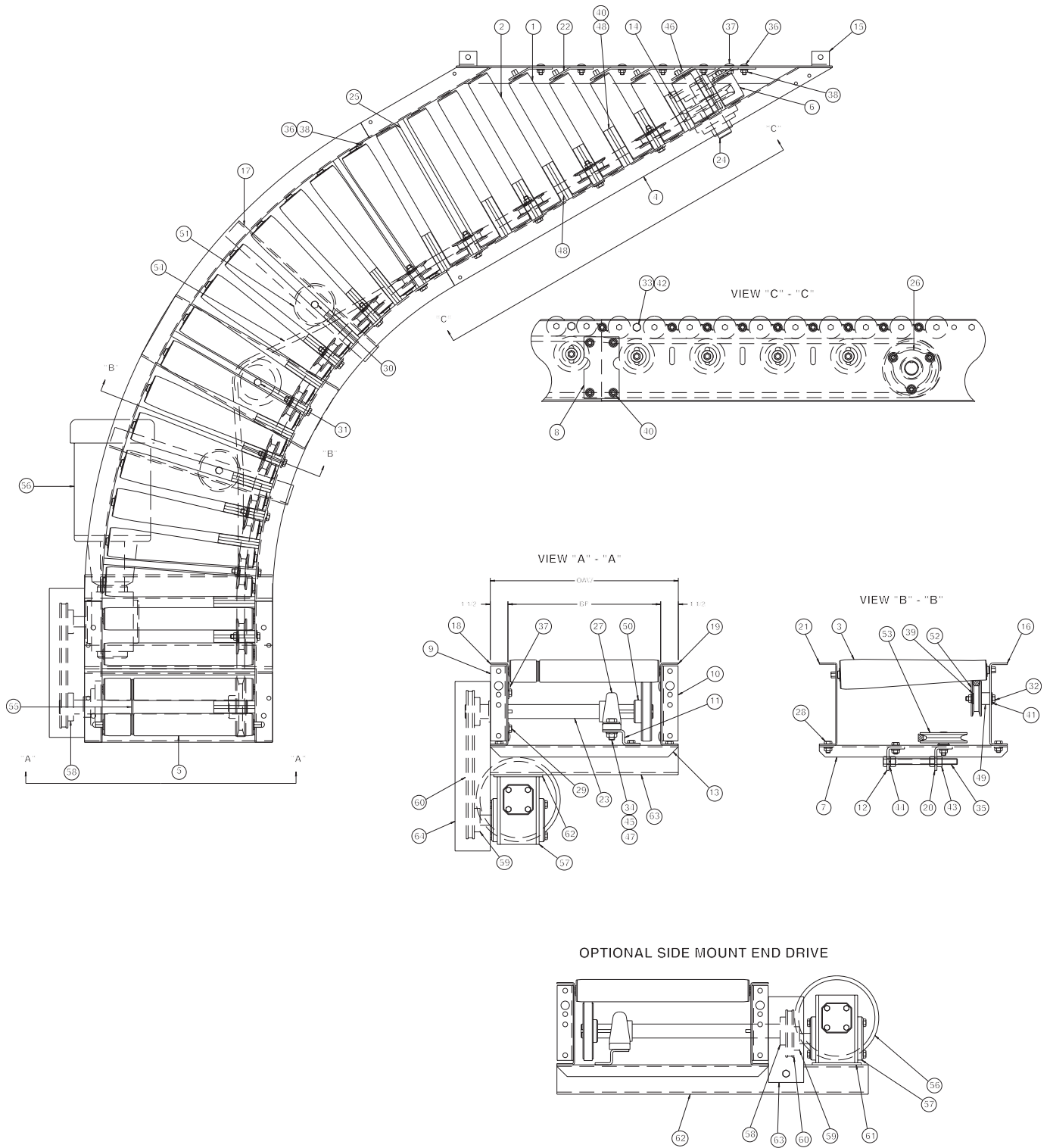

MODEL 196LRCS

PARTS LIST FOR UNIT WITH END DRIVE / SIDE MOUNT END DRIVE

ITEM #	DESCRIPTION	ITEM #	DESCRIPTION
1	196S roller (shortened for spur)	38	5/16" flange nut
2	196S roller	39	5/16" flat washer
3	254T tapered roller	40	3/8" flange nut
4	Spur assembly (specify 30° or 40°)	41	3/8" flat washer
5	196S grooved roller	42	7/16" lock washer
6	196S pinned roller (shortened for spur)	43	1/2" hex nut
7	Take-up sheave mounting channel	44	1/2" lock washer
8	Splice plate	45	1/2" flange nut
9	Bolt-in butt coupling (left hand)	46	1/8" x 1" cotter pin
10	Bolt-in butt coupling (right hand)	47	1/2" flat washer
11	Pillow block mounting bracket	48	Orange nylon finger guard
12	Take-up rod support angle	49	Black nylon sheave spacer/adaptor
13	Sheave mounting channel	50	V-belt sheave w/1-3/16" bore
14	Flange bearing mount	51	Flat idler sheave
15	Spur mounting bracket	52	Nylon 3" O.D. V-groove take-up sheave
16	32-1/2"/48" IR inside curve channel 45°/60°	53	Steel 4" O.D. V-groove take-up sheave
17	Idler sheave angle	54	V-Belt
18	Outside tangent drive side channel	55	1/8" Dia. x 9-1/2" lg. Drive band
19	Inside tangent side channel	56	Motor
20	Take-up mounting angle	57	Gear reducer
21	32-1/2"/48" IR outside curve channel 45°/60°	58	Drive sprocket
22	Roller mounting clip	59	Gear reducer drive sprocket
23	Drive sheave shaft	60	#50 (thru 1-1/2 HP) or #60 roller chain
24	Tail sheave shaft	61	Chain guard angle mount (not shown)
25	Bed spacer rod	62	Reducer push plate assembly
26	3 hole flange bearing w/1/3/16" bore	63	Underneath motor base plate
27	Pillow block bearing w/1-3/16" bore	64	End Drive Chain Guard Assembly
28	3/8" x 3/4" HHCS		
29	3/8" X 1-1/4" HHCS		OPTIONAL SIDE MOUNT END DRIVE PARTS LIST
30	3/8" X 1-1/2" HHCS	56	Motor
31	3/8" X 1-3/4" HHCS	57	Gear reducer
32	3/8" X 2-1/4" HHCS	58	Drive sprocket
33	7/16" X 1" HHCS	59	Gear reducer drive sprocket
34	1/2" X 1-1/2" HHCS	60	#50 (thru 1-1/2 HP) or #60 roller chain
35	1/2" X 6" HHTB	61	Reducer push plate assembly
36	5/16" X 3/4" carriage bolt	62	Side mount motor base plate
37	3/8" X 3/4" carriage bolt	63	Side mount chain guard assembly

Specify Unit Serial Number when ordering replacement parts to ensure proper allocation of components (See Ordering Replacement Parts on page 15).

Recommended Spare Parts are shown in red. Charted are item numbers and part descriptions. When ordering use example below.

Example: Need a replacement 138T tapered roller for 196LRCS

Part No: SN 123456 - 3 - 254T tapered roller



ILLUSTRATIONS FOR UNIT WITH END DRIVE / SIDE MOUNT END DRIVE

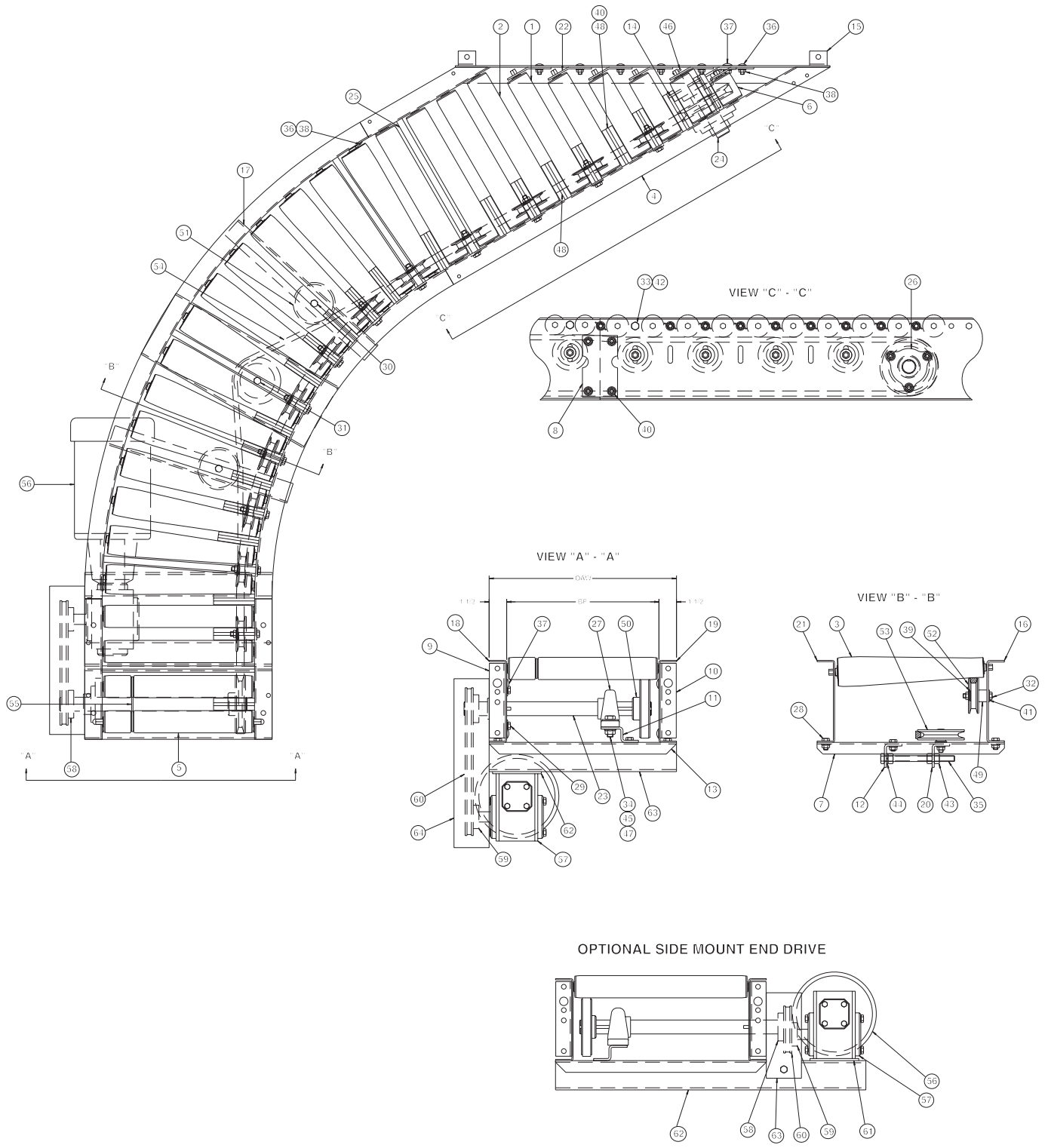



ROACH CONVEYORS

WARRANTY

- Materials used by Roach Conveyors are of good quality.
- Any part proving to be defective in materials or workmanship upon Roach inspection, will be replaced at NO cost, FOB, Trumann, Arkansas, for one year. Installation expense will be paid by others.
- Roach liability includes furnishing said part or parts; Roach is not liable for consequential damages, such as loss of profit, delays or expenses incurred by failure of said part or parts.
- Failure due to abuse, incorrect adjustments, exposure to corrosive or abrasive environment or operation under damp conditions does not constitute failure due to defects in workmanship or materials.
- Component parts not manufactured by Roach (motors, gear reducers, etc.) will be repaired or replaced at the option of their manufacturer. Contact nearest authorized service center for all warranty claims.

NOTE: Motors or gear reducers tampered with before inspection shall be considered free of ALL Warranty Claims.

--All specifications are subject to change without notice--
--Drawings are intended for illustration ONLY and are not to scale--

ROACH CONVEYORS
808 HIGHWAY 463 NORTH
TRUMANN, ARKANSAS 72472-1310
Tel 870-483-7631 Fax 870-483-7049
info@roachconveyors.com
www.roachconveyors.com