

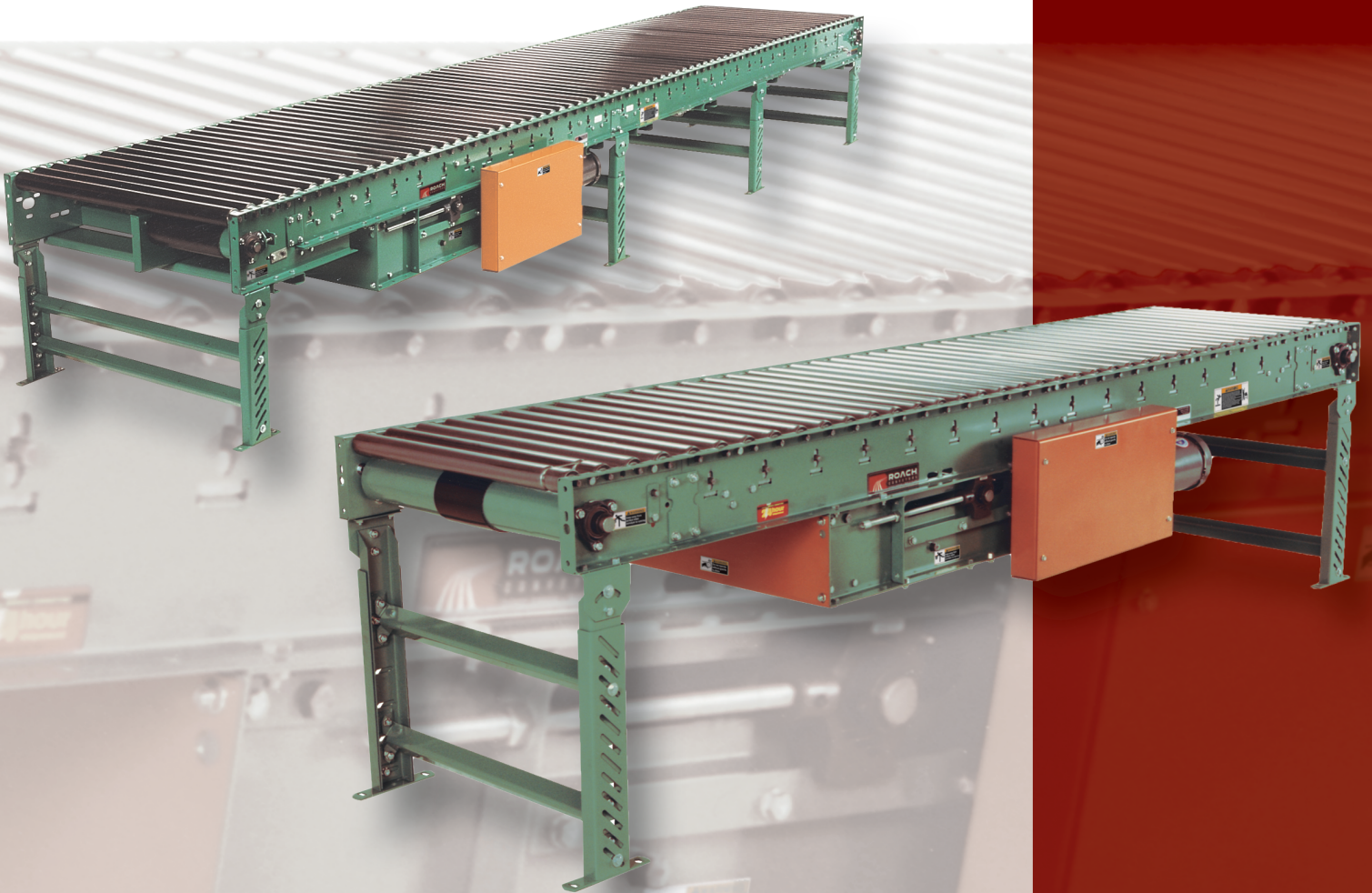

OWNER'S MANUAL



Belt Driven Live Roller

Model 638CALR • 796CALR • 251CALR

DO NOT OPERATE BEFORE READING THIS HANDBOOK
KEEP IN A SAFE PLACE - DO NOT DISCARD

TECH HANDBOOK FOR BELT DRIVEN LIVE ROLLERS

TABLE OF CONTENTS

TECH HANDBOOK FOR BELT DRIVEN LIVE ROLLERS	2	BELT TRACKING	14
-Caution Labels.....	2	-General Information.....	14
CAUTIONS, WARNINGS AND HAZARDS	3	-Pop Out Rollers and Installation of Tread Rollers.....	14
-Introduction.....	3	-Erratic Tracking at Start-Up.....	15
-Cautions, Warnings and Hazards.....	3	-Advanced Tracking Adjustments.....	15
SAFETY INFORMATION	4	SETTING PRESSURE ROLLER TENSION	16
-Important Safety Guidelines.....	4	-Model 638CALR Pressure Roller Adjustment.....	16
-Understanding Pop Out Rollers.....	4	-Model 796CALR / 251CALR Pressure Roller Adjustment.....	16
RECEIVING AND INSPECTION	5	MAINTENANCE SAFETY PRECAUTIONS	17
-Shortages, Damages and Return Authorizations.....	5	-Before Performing Maintenance.....	17
-Uncrating and Storage.....	5	-Maintenance and Follow-Up Details.....	17
GENERAL INSTALLATION INFORMATION	6	MAINTENANCE AND LUBRICATION	18
-Couplings / Attaching Bed Sections.....	6	-Maintenance Schedules.....	18
-Unit Squareness.....	6	-Recommended Lubricants.....	19
-Squaring Bed Sections.....	7	-Report on Miscellaneous Maintenance Performed.....	20
-Identifying / Installing Permanent Floor Supports.....	7	TROUBLE SHOOTING AND REPLACEMENT PARTS	21
KNEE BRACES, CASTERS AND CEILING HANGERS	8	-Trouble Shooting / Serial Plate.....	21
-Installing Knee braces and Casters.....	8	PARTS LISTS FOR 638CALR	22
-Installation of Ceiling Hangers.....	8	-Units With 4" and 8" End Drive.....	22
UNDERTRUSSING AND POLYTIER SUPPORTS	9	-Units With 4", 8" and 12" Center Drive.....	23
-Installation of Undertrussing.....	9	-Units With 4" and 8" End Side Mount Drive.....	24
-Installation of Polytier Supports.....	9	PARTS LISTS FOR 796CALR	28
INSTALLATION OF BELTING	10	-Units With 4" and 8" End Drive.....	28
-Belt Connections.....	10	-Units With 4", 8" and 12" Center Drive.....	29
-Maintaining Proper Belt Tension.....	10	-Units With 4" and 8" End Side Mount Drive.....	30
BELT PATH	11	PARTS LISTS FOR 251CALR	31
-Illustrations for Units With End Drive.....	11	-Units With 8" and 12" End Drive.....	31
-Illustrations for Units With Center Drive.....	11	-Units With 4", 8" and 12" Center Drive.....	32
START-UP PROCEDURES	12	-Units With 8" and 12" End Side Mount Drive.....	33
-Drive Chain and Sprocket Alignment.....	12	NOTES	34
-Drive Chain and Sprocket Tension.....	12	WARRANTY	35
-Gear Reducer Vent Plug.....	13		
-Preparing for Initial Start-Up.....	13		

CAUTION LABELS



ABOVE: Label attached to all protective guards (drives, roller guards, etc.)

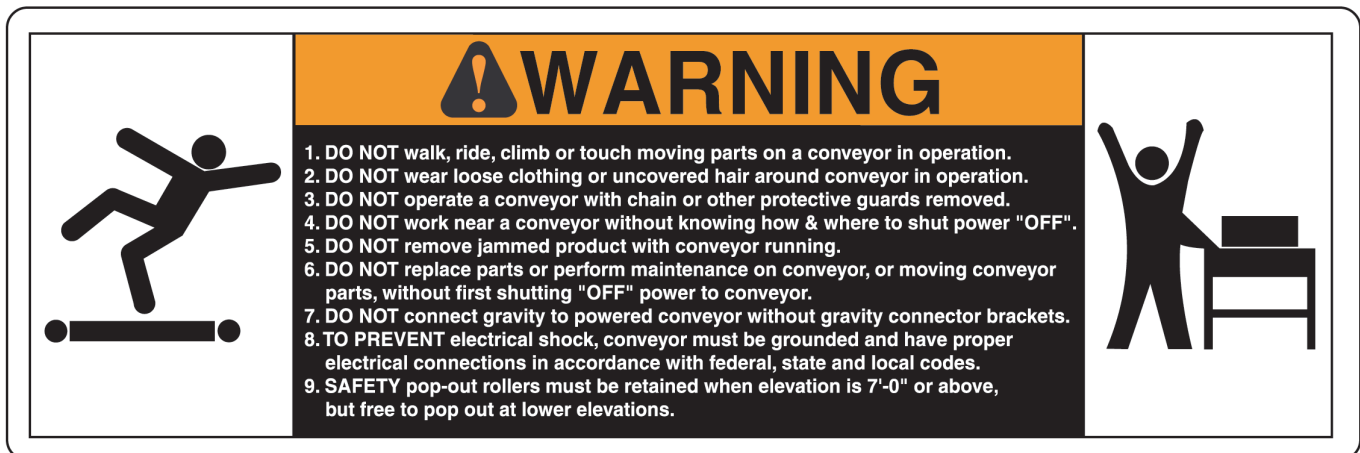

ABOVE: Label placed near all drive assemblies and at 30' intervals

CAUTIONS, WARNINGS AND HAZARDS

INTRODUCTION

This manual was prepared as a “how-to-guide” for installers, end-users and maintenance personnel. It is also intended to educate both owner (purchaser) and all individuals working around the unit, of potential hazards.

With proper installation and maintenance, conveyors are essential for achieving a variety of functions essential in today’s industrial marketplace. By following a simple, periodic maintenance schedule, the life of a typical conveyor (or, most any type of machinery-including our automobiles!) will increase when compared to a similar unit in an applica-

tion receiving little or no maintenance. You may find that a conveyor can become your best workplace friend by following simple safety guidelines. **Failure to follow even the most basic safety suggestions can result in serious personal injury.**

Conveyors contain many moving parts-pulleys, belting, chains, sprockets, shafts, rollers, etc. Therefore, it is imperative to become familiar with basic unit operation and know all points of potential hazards.

Remember, when working around or near conveyors (and **any** industrial machinery) it is **your** responsibility to become familiar with

the unit, to know potential hazards (many are noted with caution labels) and to operate unit in strict accordance with the safety guidelines in this manual.

Keep this manual in a safe place for future reference. It should be placed where appropriate personnel may maintain proper maintenance and records.

This manual must be read by all new users before operating or working near this unit.

WARNING

**DO NOT OPERATE BEFORE READING THIS MANUAL!
KEEP IN SAFE PLACE--DO NOT DISCARD!**

CAUTIONS, WARNINGS AND HAZARDS

WARNING

 Always anchor permanent supports to floor (or mounting surface). Use 3/8" x 2-1/2" (or longer) wedge anchors for permanent installation in concrete flooring.

 It is the responsibility of the customer and installation personnel to supply and install net or mesh guarding on overhead mounted conveyors to prevent product and/or debris from falling to floor in areas where required.

 To check drive sprocket alignment, shut "OFF" and lock out power source before attempting any adjustments.

 To check drive sprocket tension, shut "OFF" and lock out power source before any adjustments are attempted.

 Center drive guards **MUST** be replaced after installation or maintenance.

 Electrical controls must be designed by a qualified electrical engineer to ensure that appropriate safety features (emergency stops, pull cords, switches, etc.) are installed on unit for safe operation. Before conveyor start-up, all operators and other personnel coming in contact with unit must be properly trained and must have read accompanying Tech Handbook.

 Only trained personnel shall perform maintenance functions. Before maintenance operations are performed, shut conveyor "OFF" and lock out power source to prevent unauthorized start-up. When maintenance is completed, only authorized personnel shall be permitted to start conveyor following maintenance or other emergency shut-off.

SAFETY INFORMATION

IMPORTANT SAFETY GUIDELINES

! WARNING

WARNING: All personnel coming in contact with this conveyor should be aware of the following safety guidelines **BEFORE USING OR WORKING AROUND CONVEYOR**. **NOTE:** ALWAYS notify Roach Manufacturing® whenever any conveyor is used in an application or condition other than was originally intended. Failure to notify Roach® may allow conveyor to be operated in a hazardous operating condition. Injuries resulting from negligence or violation of safety instructions hereby removes responsibility of product liability claims from Roach®.

! Do not operate conveyor with protective guards removed. This includes chain guards, belt guards, snub roller guards, center drive guards and any other safety guard.

! Do not walk, ride, climb, or touch moving parts on a conveyor in operation.

! Do not wear loose clothing or uncovered hair around conveyor.

! Do not work near conveyor without knowing how & where to shut power "OFF" and lock out power source.

! Do not remove jammed product with conveyor running.

! Do not replace parts or perform maintenance on conveyor, or moving conveyor parts, without first shutting "OFF" power to conveyor and locking out power source.

! Do not connect gravity to powered conveyor without safety gravity connector brackets.

! To prevent electrical shock, conveyor must be grounded, and have proper electrical connections in accordance with federal, state, and local codes.

! Safety pop out rollers in conveyors installed above 7'-0" elevation must be retained by guard rail, clips, etc. Safety pop out rollers must be allowed to pop out

when conveyors are installed at or below 7'-0" elevation.

! It is the responsibility of conveyor end-user to comply with all safety standards including OSHA and other federal, state, and local codes or regulations. Install protective guarding and other related safety precautionary equipment to eliminate hazardous operating conditions which may exist when two or more vendors supply machinery for related use.

! Any violation of above safety instructions hereby removes all product liability claims from Roach Manufacturing Corporation®.

UNDERSTANDING POP OUT ROLLERS

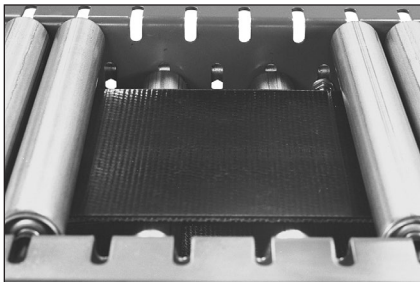

SLOTTED FRAME ALLOWS ROLLERS TO EASILY POP OUT (rollers removed for clarity)

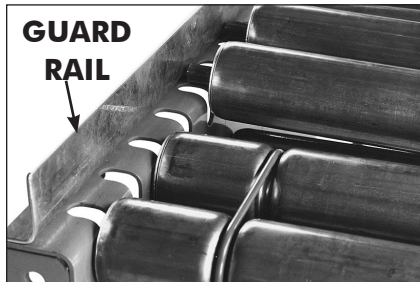

WHEN GUARD RAIL IS ADDED, DO NOT COVER POP OUT SLOTS IN CONVEYOR FRAME*

WARNING: Belt driven live roller conveyors must have safety pop out tread rollers when installed below 7'-0" elevation. Conversely, when installed at 7'-0" or **greater** elevation, tread rollers must **NOT** be allowed to pop out of frame. Shut conveyor OFF and lock out power source until above safety considerations are completely adhered to.

***NOTE:** Guard rail may be used to hold rollers in frame when installed at 7'-0" or higher elevations.

In most instances, live roller conveyor frames are equipped with slots in the frame for tread rollers. Why is this necessary? When installed below 7'-0" elevation, tread rollers must be designed to pop out of the frame to prevent injury to operator or individuals coming in contact with tread rollers. However, when installed at 7'-0" and **greater** elevation,

tread rollers must **NOT** be allowed to pop out. Individuals stationed below the conveyor could be injured by rollers that inadvertently become free from conveyor frame. Therefore, a belt driven live roller originally supplied with slotted frame and pop out rollers, must be modified if it is moved to 7'-0" or higher elevation. A special hold-down angle must be installed

to eliminate pop out rollers. Also, when a live roller conveyor that does not feature pop out rollers, is used in an application below 7'-0" elevation, conveyor **MUST** be modified to include safety pop out rollers.

Contact Roach national sales at 870-483-7631 with conveyor serial number for additional information.

RECEIVING AND INSPECTION SHORTAGES, DAMAGES AND RETURN AUTHORIZATIONS

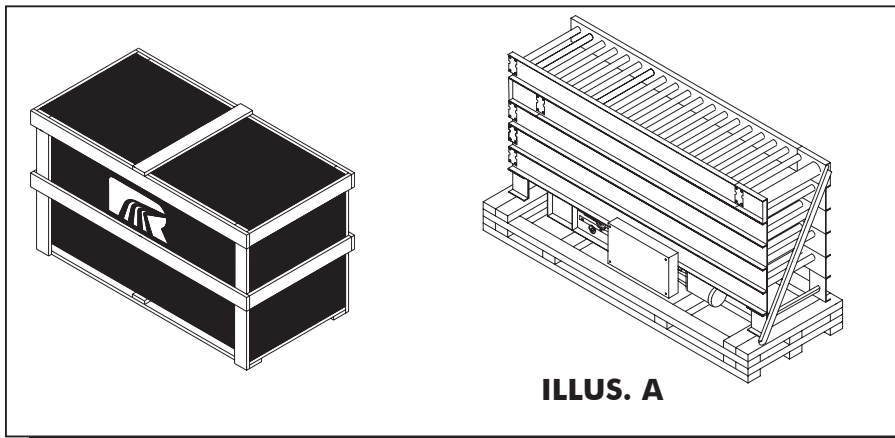

NOTE: Do not return goods to factory without prior, written return authorization. Unauthorized returns are subject to refusal at factory.

Before uncrating, check the quantity of items received against bill of lading to confirm that all material has been received. Examine the condition of the equipment to determine if any damage has occurred.

Also, it is possible that some items may become separated from the original shipment. Therefore, when receiving goods, it is imperative that the bill of lading (or, accompanying

freight documentation) be checked to ensure receipt of ALL units ordered including ALL accessories.

Damage and/or shortage in shipment should be reported immediately to both vendor and carrier. Obtain a signed damage report from carrier agent and send copy to vendor. **Do not repair any damage before obtaining this report.**

For damaged shipments, consult factory to determine if entire shipment must be returned to factory for repair or if an immediate order should enter production to produce a new, replacement shipment.

In illustration A above, model 796CALR is shown pelletized with belting and return rollers for all bed sections mounted to top of crate which is prepared for shipment.

UNCRATING AND STORAGE

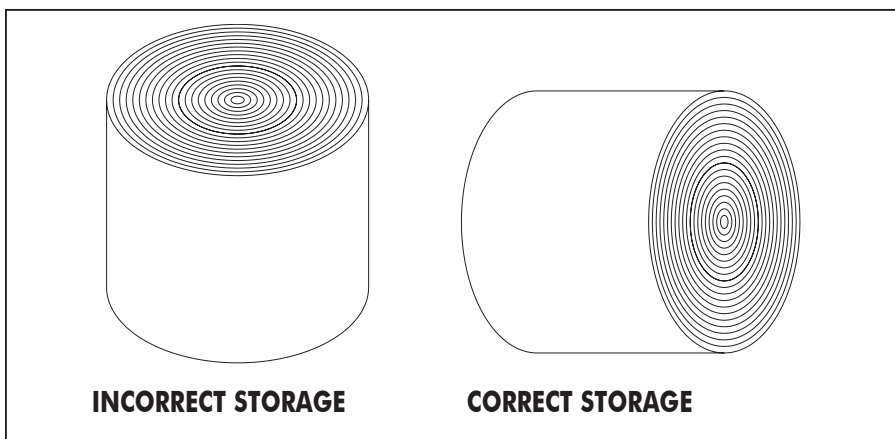

NOTE: Never store belt placed directly on floor. Elevate belting to prevent contact with floor moisture.

After receipt and initial inspection is completed, carefully remove crating and look for essential components and specific accessories that may have been boxed and attached (or 'banded') to crating material. Pop out tread rollers, guard rails and hardware are often packaged and shipped in this manner. Save all hardware for subsequent use by installa-

tion personnel.

The drive section will be shipped mounted to its actual operating bed section (see illustration at top of page). Intermediate bed sections are shipped mounted on top of drive bed section with formed steel stiffener (spacer) brackets.

Belting must be housed in dry quarters.

Do not store belt on edge (see illustration above). Also, never store belt placed directly on floor. Elevate belting to prevent contact with floor moisture.

Some items (electric motors, gearbox, etc.) may be shipped direct from their manufacturer to final destination. Thus, the conveyor may consist of two or more separate shipments.

GENERAL INSTALLATION INFORMATION

COUPLINGS / ATTACHING BED SECTIONS

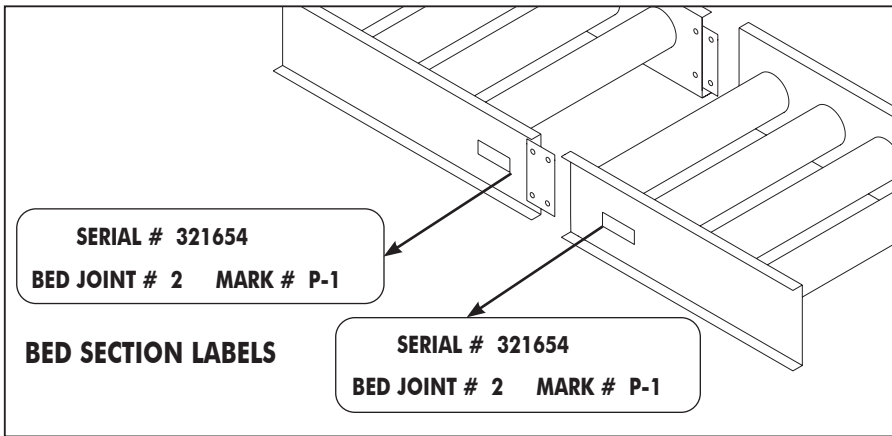

NOTE: It is critical for bed sections to be field assembled in proper sequence following bed section labels.

When preparing to install conveyor, first locate all component sections in the actual installation area. After uncrating, place unit bed sections conveying side up. Each bed section is marked to indicate proper sequence for mating (see illustration above for typical bed section labels).

It is critical for bed sections to be field

assembled in proper sequence following bed section labels. Refer to bed section drawing for location of supports and assemble as shown.

Conveyors are set up at the factory, bed section labels are applied, unit is test run and receives rigorous quality assurance inspection. At this time unit becomes field-ready. Therefore, it is critical that

field installation personnel re-assemble unit by mating beds in accordance with bed section labels (and bed section drawing).

Create a reference base line on floor by marking a chalk line along the centerline of conveyor. Follow base line when installing unit.

UNIT SQUARENESS

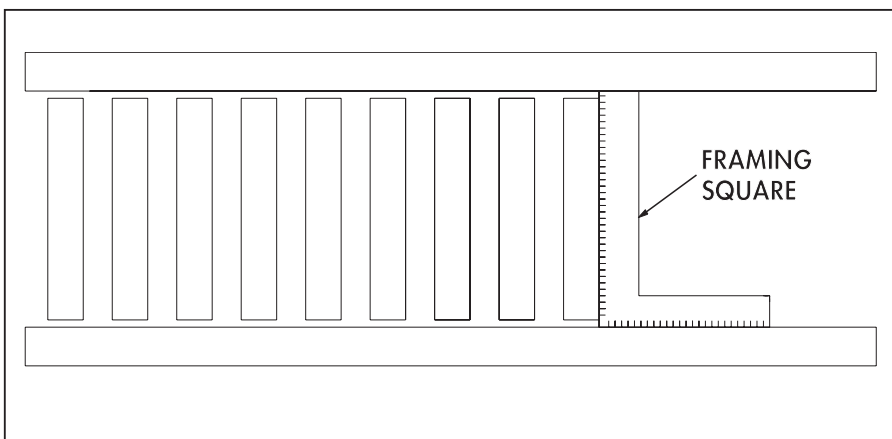

NOTE: One of the most critical elements of proper installation is unit squareness. Check pulleys, snub and return rollers and square each with unit bed.

Use mechanical hoist (fork truck or other available means) to raise bed sections to approximate installed elevation. Mate intermediate sections with splice plates to join bed sections (see illustration at top of page).

One of the most critical elements of proper installation is unit squareness. Check drive pulley, tail pulley, snub roller (if

used in drive assembly) and return roller assemblies to ensure these components are square with unit bed. A framing square can be utilized to confirm that conveyor frame is square. Also, a diagonal measurement across the conveyor frame may be used to determine if the frame is out of square. If measurement is not equal, the frame is not square. Rollers will be skewed and product will run to

one side of the conveyor or perhaps, **off** of the conveyor in some cases. The importance of unit squareness is perhaps the single most critical stage of installation with belt driven live roller conveyors. If unit is out of square, proceed to next section for adjustments required to square frame and components.

GENERAL INSTALLATION INFORMATION

SQUARING BED SECTIONS

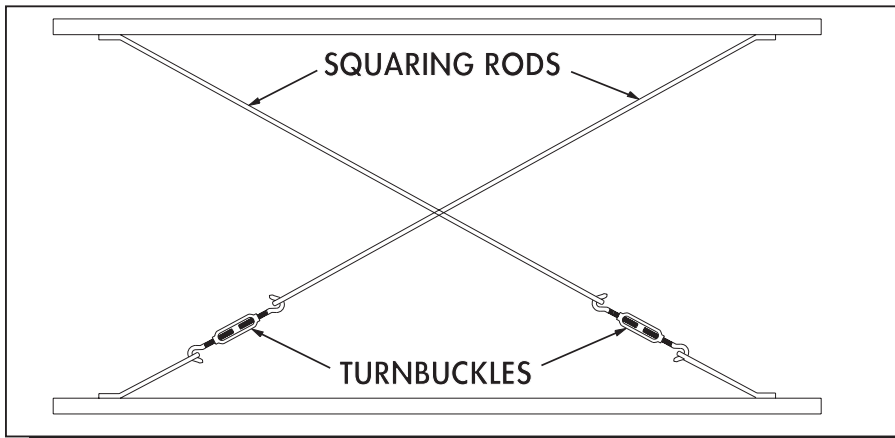

NOTE: Squaring rods are supplied on the underneath side of bed sections and feature a turnbuckle assembly which is used to square accompanying bed sections. Adjust the turnbuckle until the frame is squared.

When conveyor section is determined to be out of square, adjustments must be made before proceeding to next section.

In illustration above, “x-bracing” or “squaring rods”, are used to square a frame that has become “racked” or is otherwise out of square. It is common for bed sections to become racked during transit, thus requiring adjustment during

field assembly. Squaring rods are supplied on the underneath side of bed sections and feature a turnbuckle assembly which is used to square accompanying bed sections. Adjust the turnbuckle until the frame is squared. Confirm by again taking a diagonal measurement. The frame is then square when diagonal measurements from opposite sides are equal in measurement.

Next, tighten bolts in splice plates when frame is square. Finally, conveyor must be installed at level elevation across the width to prevent erratic belt tracking or to prevent package from travelling to one side of conveyor (which is especially possible on long conveyor lines when unit is not installed level across the width).

IDENTIFYING/INSTALLING PERMANENT FLOOR SUPPORTS

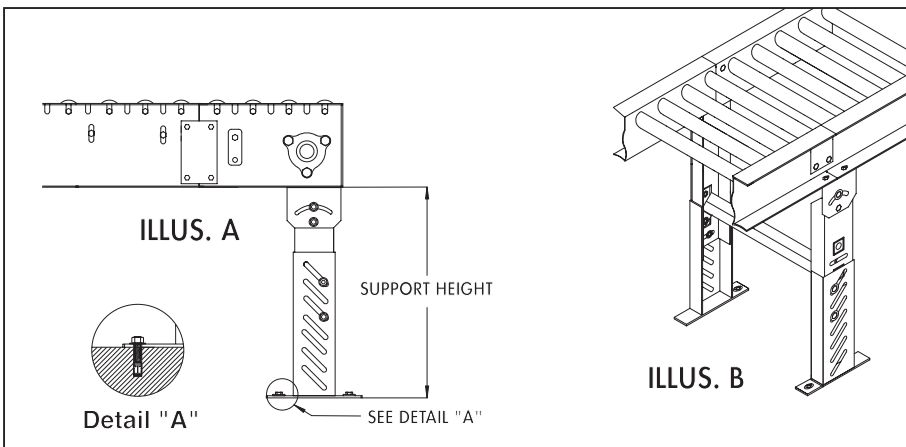

CAUTION: Always anchor permanent supports to floor (or mounting surface). Use 3/8" x 2-1/2" (or longer) wedge anchors for permanent installation in concrete flooring.

*MINIMUM SUPPORT CHANNEL HEIGHT					
MEDIUM DUTY			HEAVY DUTY		
SM-1	7-1/4"	SM-7	34-1/4"	SM-1	6-1/4"
SM-2	10-1/4"	SM-8	46-1/4"	SM-2	7-3/4"
SM-3	13-1/4"	SM-9	58-1/4"	SM-3	10-3/4"
SM-4	16-1/4"	SM-10	70-1/4"	SM-4	13-3/4"
SM-5	20-1/4"	SM-11	80-1/4"	SM-5	16-3/4"
SM-6	24-1/4"	SM-12	92-1/4"	SM-6	19-3/4"
				SM-7	25-3/4"
				SM-8	31-3/4"
				SM-9	43-3/4"
				SM-10	55-3/4"
				SM-11	67-3/4"
				SM-12	79-3/4"

Permanent supports may be installed on conveyors at various locations. However, it is most common to use single tier permanent floor supports at each end of a powered section (see illustration A above) and where intermediate bed sections are adjoined (see illustration B above). Notice intermediate supports have two lag bolts in a diagonal pattern while end (terminal) supports have four lag bolts, one in each of the four foot plate mount-

ing holes. When two (or more) powered conveyors are placed end-to-end, a single tier permanent support may be used at the end junction commonly supporting both units. Check load rating of support before using this method of installation.

Adjust elevation to top of conveyor by loosening bolts in support uprights, raising or

lowering conveyor and fully tightening bolts at desired elevation. Tighten all bolts in supports **before** unit operation. Complete support installation by lagging support attachment plates to floor. Confirm that unit is level across width of conveyor before completing final support height adj.

*Supports are normally shipped at minimum support height. See chart above.

KNEE BRACES, CASTERS AND CEILING HANGERS

INSTALLING KNEE BRACES AND CASTERS

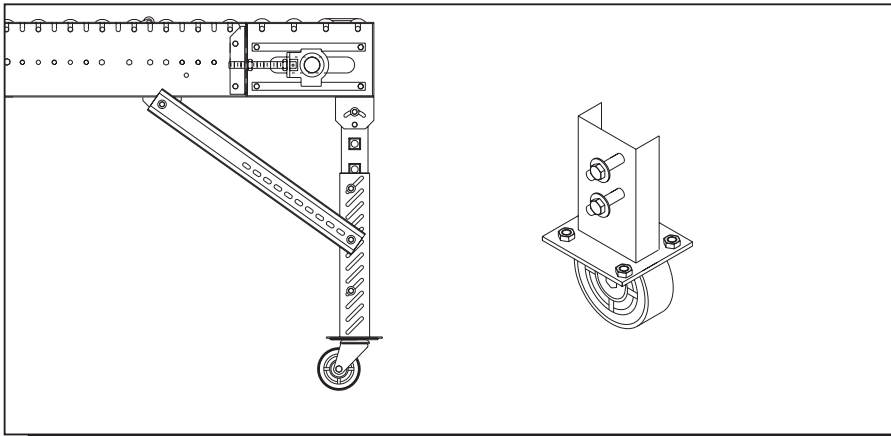

NOTE: Install knee brace (when supplied) after final permanent support installation and elevation adjustment.

Knee braces add strength to permanent supports and stability to units in portable applications. Install knee brace (when supplied) after final permanent support installation and elevation adjustment. Its pivot bracket is bolted to underneath side of lower conveyor flange and slotted end is attached to outer side of support.

Castors (when supplied) are generally installed at the factory. However, when receiving casters direct from their supplier, final attachment to support is necessary. A special slotted pre-punched caster attachment plate is supplied on supports designed for casters.

A standard support is not designed for attachment to casters. Field modification or replacement of outside support assemblies is required.

INSTALLATION OF CEILING HANGERS

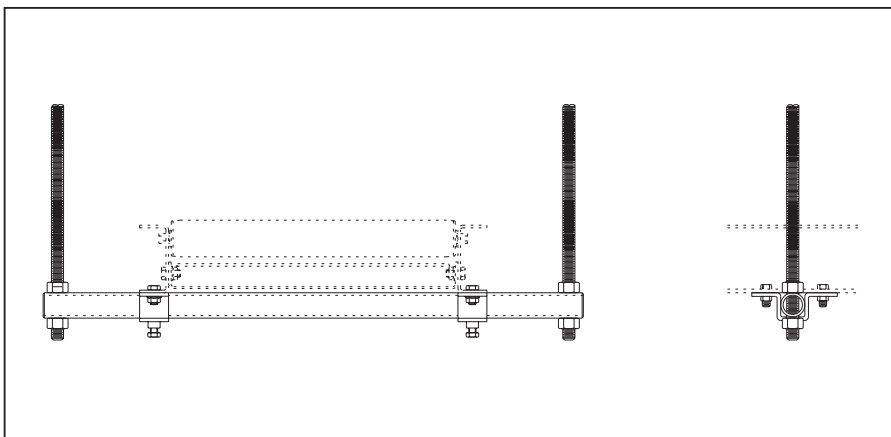

WARNING: It is the responsibility of the customer and installation personnel to supply and install net or mesh guarding on conveyors mounted overhead to prevent product and/or debris from falling to floor in areas where required.

Ceiling hangers are frequently used in high-elevation applications for suspension from ceiling. The 5/8" diameter (#11 UNC) all threaded rod is supplied to allow infinite vertical adjustment along the length of the suspension rod (see illustration above).

Attach and firmly tighten U-shaped retainer ("hat") bracket to underneath side of

lower conveyor flange with hardware provided to hold cross pipe (1" inside diameter) against underneath side of conveyor.

Do not tighten cross pipe locking bolts (these attach in the bottom of the U-shaped retainer bracket) until threaded suspension rods have been firmly secured to ceiling structure.

To adjust conveyor elevation, tighten or loosen lower nut and jam nut on threaded suspension rods to desired elevation. A lock washer must be used on suspension rods to maintain unit at desired elevation.

When unit is at operating elevation and unit has been levelled across bed width, tighten locking bolts in U-shaped bracket to secure position of cross pipe.

UNDERTRUSSING AND POLYTIER SUPPORTS INSTALLATION OF UNDERTRUSSING

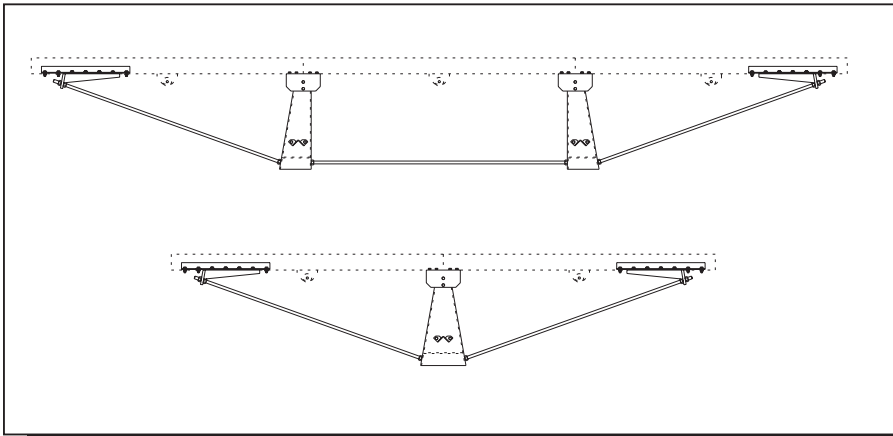

WARNING: It is the responsibility of the customer and installation personnel to supply and install net or mesh guarding on conveyors mounted overhead to prevent product and/or debris from falling to floor in areas where required.

When installing some conveyors, using a permanent support or ceiling hanger is simply not practical. In this situation, three bed sections (maximum) may be joined together utilizing truss assembly, mounted underneath conveyor (see illustration above).

diagonal connector rod is used not only to support the intermediate bed section joint but it is instrumental for setting and maintaining proper tension across intermediate spanned beds.

Use diagonal connector rods to level the undertrussed beds both along and across the conveyor. Remember that the tension must provide adequate for both dead load (conveyor weight) and product load during unit operation.

Adjoin beds on floor using both connector rod support assemblies and connector rods (5/8" diameter-11UNC threaded rod). The

Use mechanical hoist (fork truck or other means) to raise pre-assembled bed sections (with undertrussing) to desired elevation for final installation.

INSTALLATION OF POLYTIER SUPPORTS

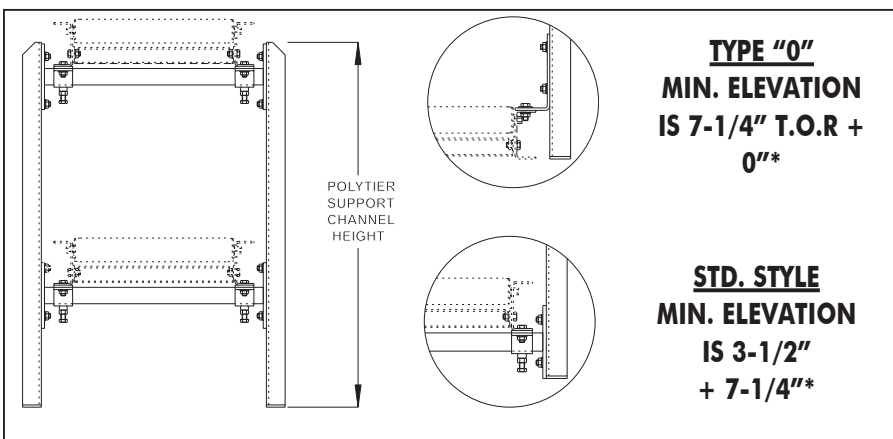

NOTE: To install, raise conveyor to desired elevation, place cross pipe underneath lower conveyor flange, attach cross pipe to upright legs and use U-shaped retainer ("hat") bracket to connect cross pipe to lower conveyor flange.

POLYTIER SUPPORT CHANNEL HEIGHT					
PSM-1	23"	PSM-6	53"	PSM-11	83"
PSM-2	29"	PSM-7	59"	PSM-12	89"
PSM-3	35"	PSM-8	65"	PSM-13	95"
PSM-4	41"	PSM-9	71"	PSM-14	101"
PSM-5	47"	PSM-10	77"	PSM-15	107"

Polytier supports provide convenient installation method for two or more tiers of conveyor. To install, raise conveyor to desired elevation (approximate). Place 1" inside diameter cross pipe underneath lower conveyor flange. Attach cross pipe to upright legs. Use U-shaped retainer ("hat") bracket to connect cross pipe to lower conveyor flange. Do not tighten fully at this time.

There are two styles of attachment brackets available for use with polytier supports. Minimum elevation style (see TYPE "O", illustration above) offers lowest unit elevation, 0" + frame depth utilizing L-shaped mounting bracket. Standard elevation style offers unit elevation of 3-1/2" + frame depth and includes bracket welded to cross pipe which is bolted to upright legs during installation.

When unit is at operating elevation and unit has been checked across width for level, tighten locking bolts in U-shaped bracket. Add knee braces for unit rigidity.

***NOTE:** Overall conveyor height is dictated by type of drive assembly used-i.e. underneath, center drive, sidemount, etc.

INSTALLATION OF BELTING

BELT CONNECTIONS

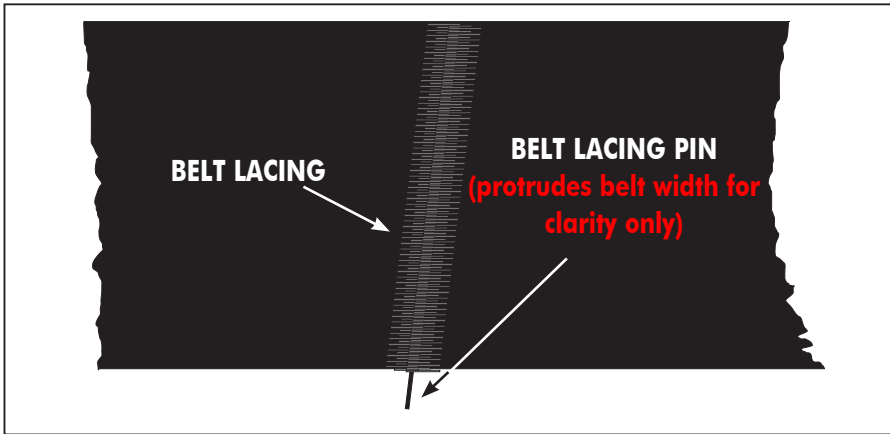

CAUTION: Belt lacing must be kept in good condition for safe work environment.

BELT WIDTH	LACING ANGLE
6"	10°
12"	5°

Conveyor belting is cut to proper length, laced and assembled on conveyor at the factory. It is test run and inspected before it is shipped to its final destination.

Before field installation of belting, the correct side to be placed down must be determined. 6" wide PVC belting is supplied as "COS" (cover one side, friction surface other side). The friction surface offers decreased

friction and less driving force. The friction side appears dull and grainy; the cover side darker and shiny. On model CALR, the cover side is placed down with the **friction** surface up which drives tread rollers. On LR models, **cover** side of belt is placed up. Therefore, for temporary accumulation, place friction surface up; for transportation ONLY, place cover side up.

If unit is shipped "knocked down," belt must be re-threaded on unit during installation (see opposite page). Join ends of belt as shown above with lacing pin. Loosen threaded take-up rods (if necessary) at take-up pulley **equal** amount on both sides and re-adjust when belt is installed keeping pulley square with conveyor bed. A belt puller can also be used to join belting.

MAINTAINING PROPER BELT TENSION

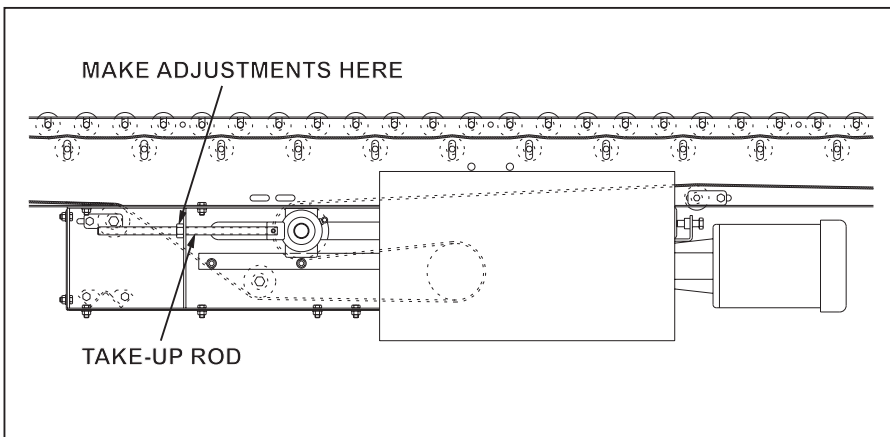

CAUTION: Belt lacing must be kept in good condition for safe work environment. Also, do not operate unit with improper belt tension. Unit is subject to abnormal wear and maintenance when operated with belt incorrectly adjusted.

Maintaining proper belt tension is vital to unit operation. Enough tension should be maintained so that drive pulley does not slip under fully loaded conditions.

It is perfectly normal for a belt to stretch (in varying climatic conditions) under rated loading. Therefore, a short belt insert or "belt patch" (or patches) is provided for future removal when belting has stretched beyond means of conveyor take-

up assembly. For yet additional belt take-up, the belt should be cut and re-laced to maintain proper belt tension.

To adjust conveyor take-up, adjust position of take-up rod (see illustration above) as required. Remember to equally adjust both sides to hold take-up pulley square (to maintain unit squareness for belt tracking).

Operating unit with slipping belt will decrease life of both belting and pulley lagging. Also, do not operate unit with too much tension on belt. This will decrease belt life and may harm unit drive and take-up bearings. Over tensioning belt requires additional horsepower from unit drive.

BELT PATH ILLUSTRATION FOR UNITS WITH END DRIVE

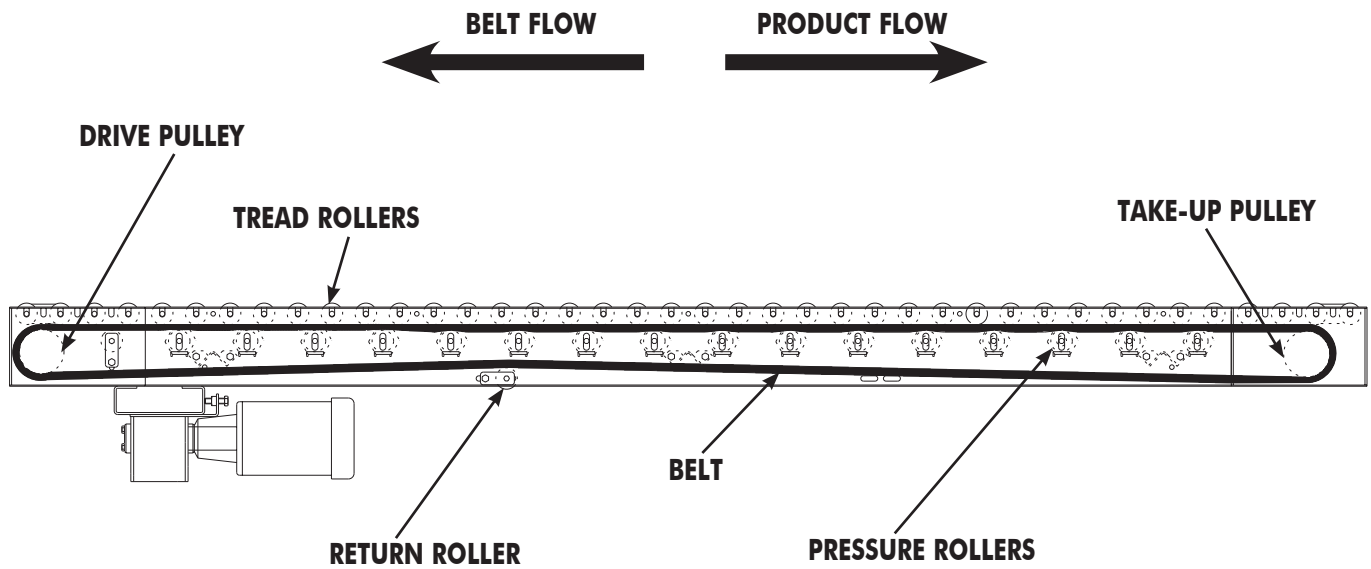

WARNING: Belt driven live roller conveyors must have safety pop out tread rollers when installed below 7'-0" elevation. When installed at 7'-0" or **higher** elevation, tread rollers must **NOT** be allowed to pop out of frame.

ILLUSTRATION FOR UNITS WITH CENTER DRIVE

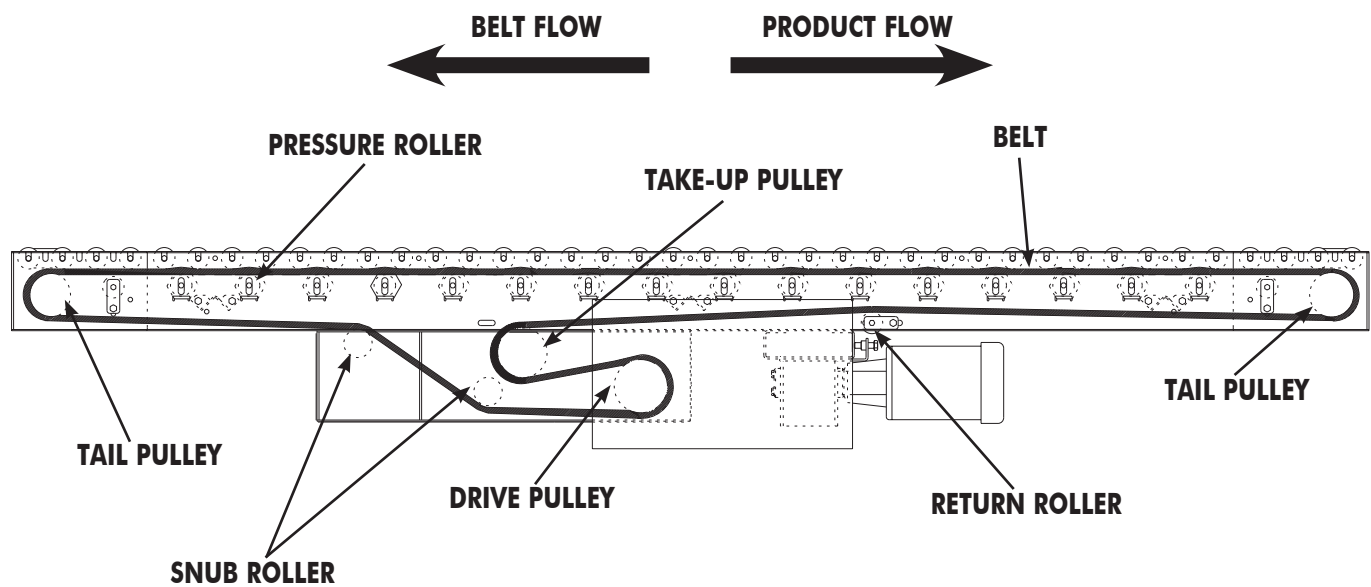

WARNING: Belt driven live roller conveyors must have safety pop out tread rollers when installed below 7'-0" elevation. When installed at 7'-0" or **higher** elevation, tread rollers must **NOT** be allowed to pop out of frame.

START-UP PROCEDURES

DRIVE CHAIN AND SPROCKET ALIGNMENT

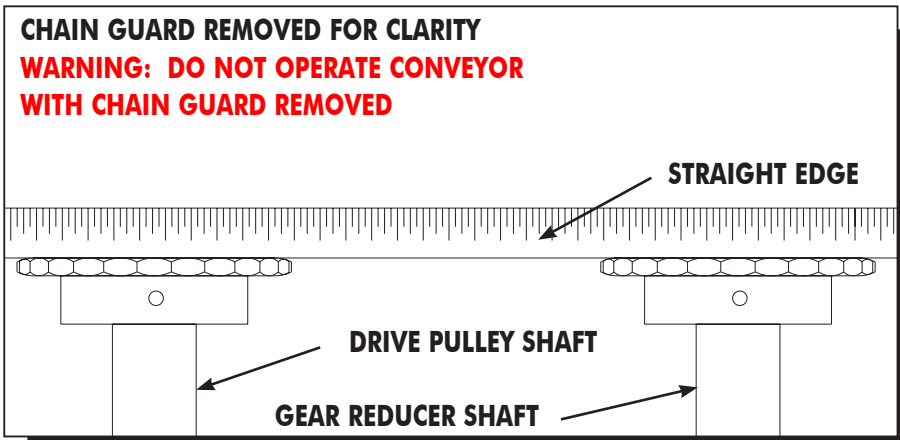

WARNING: To check drive sprocket alignment, it is imperative that conveyor is shut "OFF" and power source is locked out before any adjustments are attempted.

Set up and maintenance of drive sprocket and drive chain alignment is critical. A periodic visual inspection is recommended to confirm alignment of drive components (which includes both drive sprockets and drive chain). Should set screws become loose, drive sprockets are subject to excessive wear and ultimately, to untimely replacement.

To check drive sprocket alignment, it is imperative that conveyor is shut "OFF" and power source is locked out before any adjustments are attempted. Remove chain guard cover and place straight-edge (see illustration above) across face of both drive sprockets. If re-alignment is necessary, loosen set screws and adjust drive

sprockets as required. **Remember to securely tighten set screws when alignment is complete.**

Before replacing chain guard cover, check drive chain tension as described in following section, "Drive Chain and Sprocket Tension."

DRIVE CHAIN AND SPROCKET TENSION

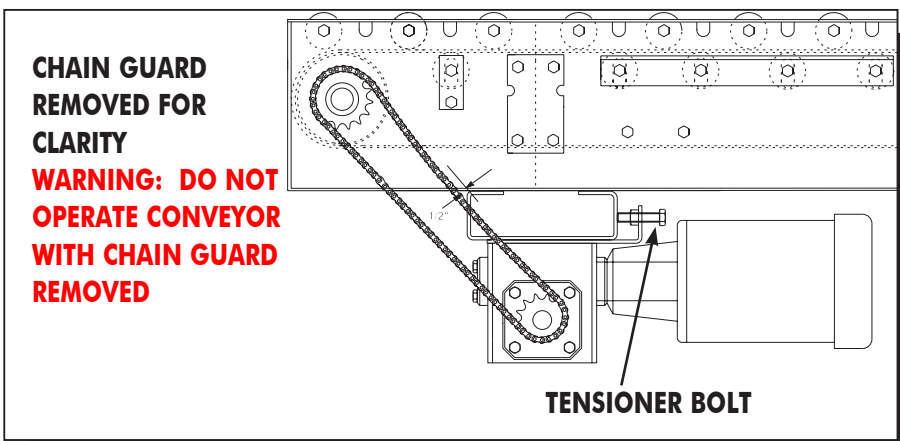

WARNING: To check drive sprocket tension, shut "OFF" and lock out power source before **any** adjustments are attempted.

Maintaining proper chain tension is especially important. Again, a periodic visual inspection is recommended to ensure chain tension within a pre-determined operating range.

Remember, before any adjustments are attempted, conveyor must be shut "OFF" and power source locked out.

Before replacing chain guard cover,

check to see if drive chain is operating within 1/2" range (see above illustration). If unit is out of tolerance, adjustment is necessary.

To adjust drive chain tension, tensioner bolt located on reducer push plate should be tightened (rotate clockwise) if chain tension is loose. Tighten until proper operating

range is achieved. If chain tension is too tight, loosen tensioner bolt (rotate counter-clockwise) as required. When adjustment is complete replace chain guard cover.

WARNING: Do not operate unit until chain guard cover is replaced. Serious operator or other personal injury could result if protective guarding is not replaced.

START-UP PROCEDURES

GEAR REDUCER WITH POSIVENT®

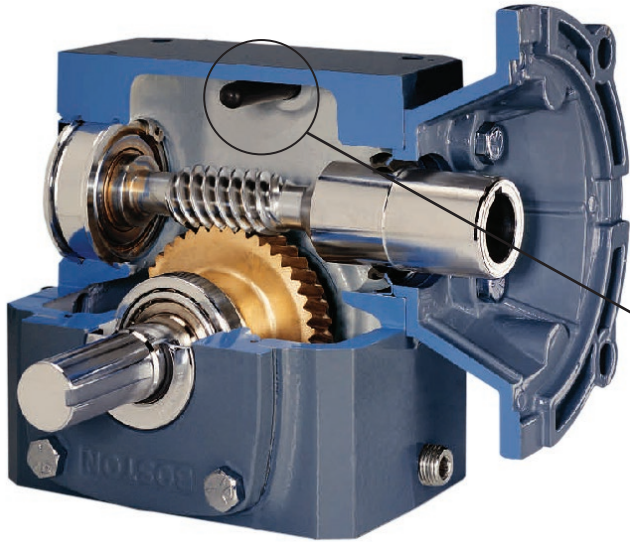

NOTE
The gear reducer is supplied with a "PosiVent®". No vent plugs are required.

PosiVent Unique design incorporates a single seam construction. Factory filled with synthetic lubrication for universal mounting. Lubed for life, no oil changes are required.

To expedite the installation and start-up process, all gear reducers are shipped filled with oil. The reducers are sealed and lubed for life and require no oil changes.

PREPARING FOR INITIAL START-UP



⚠ DANGER
WARN ALL PERSONNEL TO KEEP CLEAR OF CONVEYOR DURING UNIT START-UP
Electrical controls must be designed by a qualified electrical engineer to ensure that appropriate safety features (emergency stops, pull cords, switches, etc.) are installed on unit for safe operation. Before conveyor start-up, all operators and other personnel coming in contact with unit must be properly trained and must have read accompanying Tech Handbook.

Before conveyor start-up, all operators and other personnel coming in contact with unit must be properly trained and must have read accompanying Tech Handbook.

Provisions must be in order to instruct all personnel coming in contact with conveyor on the location of emergency stops, pull cords, etc.

A routine maintenance program should be implemented before unit is placed into operation so that fundamental unit components are attended to. This maintenance program should include an inspection to ensure that any dangerous or hazardous operating conditions are noted and IMMEDIATELY corrected, as well as

including electrical and mechanical unit inspections and corrections.

Finally, when conveyor is initially started, an immediate visual inspection should include motor, gear reducer, belt tracking (discussed in following section under "Belt Tracking") and related adjustments noted in handbook for unit/component corrections.

BELT TRACKING

GENERAL INFORMATION

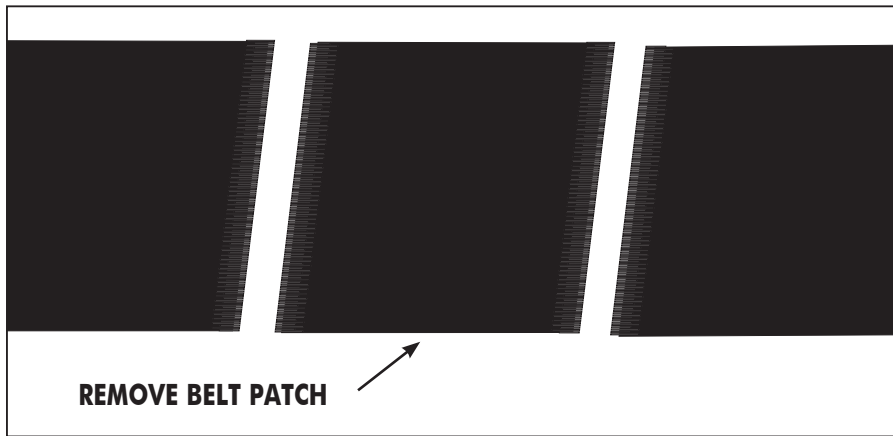

CAUTION: Upon initial operation the belt will stretch. To maintain proper belt tension, adjustment of the take-up pulley or removal of belt patch will be required. ONLY trained personnel should make belt tracking adjustments.

Upon initial use belting will stretch after a few days of operation. Remember that maintaining proper belt tension is a crucial element in belt tracking. Therefore, this stretching of a belt when placed into operation may affect its ability to track. Adjustment of the take-up pulley will likely adequately compensate for initial stretch. However, depending on the overall unit

length, removal of a belt patch may be necessary to correct.

The return direction of the belt must clear supports, ceiling hangers, floor openings, etc. Dragging on such components will contribute to belt tracking problems and is certain to damage belting at extended intervals. Also, do not allow belt to rub against conveyor side frame.

In a reversible application, a belt that runs off to one side in one direction will likely run off to the other side when operated in the opposite direction.

Belt must be tracked in both unloaded and loaded situations. See following step for installation of tread rollers to track belt in loaded situation.

POP OUT ROLLERS & INSTALLATION OF TREAD ROLLERS

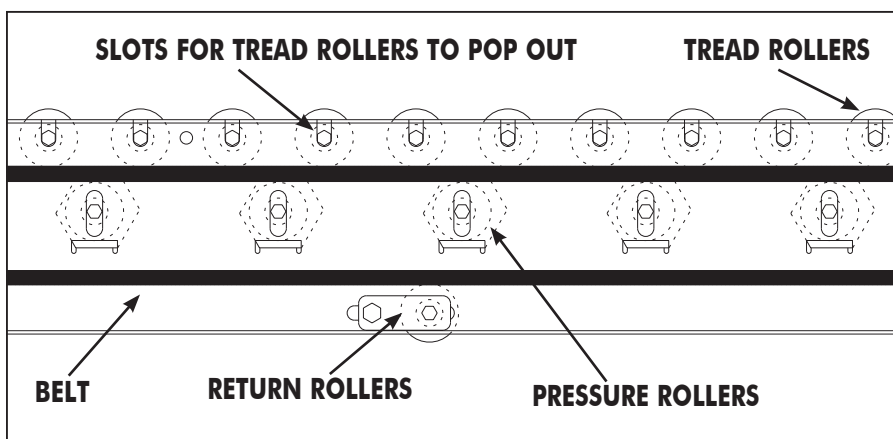

CAUTION: ONLY trained personnel should make belt tracking adjustments. Shut unit "OFF" and lock out power source before attempting adjustments in belt tracking.

WARNING: Belt driven live roller conveyors must have safety pop out tread rollers when installed below 7'-0" elevation. Conversely, when installed at 7'-0" elevation or **greater**, tread rollers must **NOT** be allowed to pop out of frame.

In most instances, live roller conveyor frames are equipped with slots in the frame for tread rollers. When installed below 7'-0" elevation, tread rollers will pop out of the frame to prevent injury to operator or individuals coming in contact with tread rollers. Live rollers installed at 7'-0" or higher elevations, require tread rollers to be installed in a **NON** pop out design to prevent rollers from popping out

and causing injury to individuals stationed below the conveyor. Therefore, the frame should be punched rather than slotted OR a hold down angle must be used to eliminate pop out rollers in high elevation applications. (See "UNDERSTANDING POP OUT ROLLERS", page 4).

Remove tread rollers from shipping crate and install in conveyor. Once installed, confirm that belt will track under loaded conditions. If belt does not track after tread rollers are installed, further adjustments will be required. Confirm that return rollers, beds and all pulleys are squared. Skewing of return rollers in small increments may complete belt tracking.

BELT TRACKING ERRATIC TRACKING AT START-UP

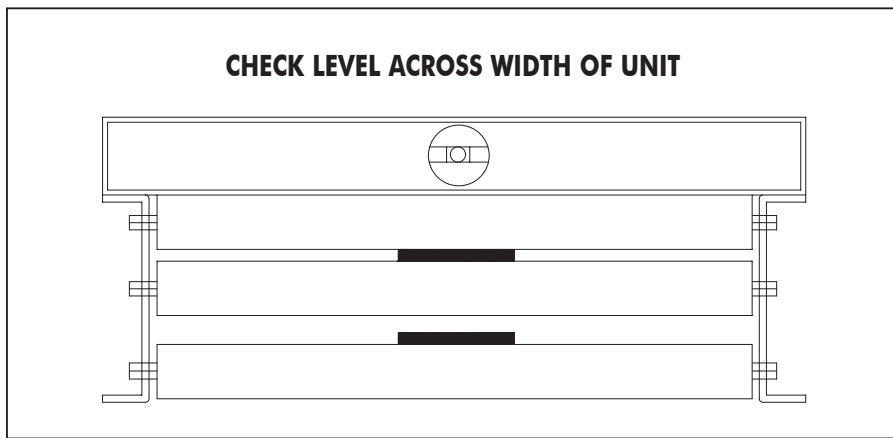

CAUTION: Upon start-up, if belt tracks to one side of unit, turn unit "OFF", lock out power source and confirm that conveyor is square and that all prime tracking components are square with bed. Belt tracking adjustments should be performed by trained personnel ONLY.

Improper tracking of conveyor belting should be considered a "systems" problem rather than solely a deficiency in the belt. To explain, a belt is tracked with adjustments made to the conveyor rather than just the belting.

Upon start-up, if belt tracks to one side of unit, turn unit "OFF", lock out power source and confirm that conveyor is

square. All prime tracking components must be square with bed including drive pulley, tail pulley, snub roller and return rollers. Both sides of take-up should be adjusted exactly the same amount. The conveyor should be level across the width of the unit. Confirm that the belt has been properly threaded (see "Belt Path" section) and that belt lacing is square

with the belt edges. Make adjustments as necessary; however, all adjustments should be made in small increments.

Start conveyor again and operate for at least ten minutes once initial phase of adjustments are complete. If belt continues to track erratically, turn unit "OFF" and proceed to following section.

ADVANCED TRACKING ADJUSTMENTS

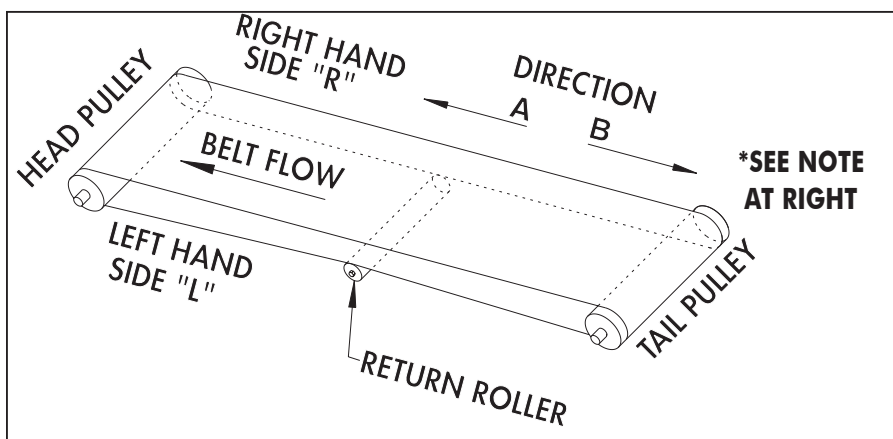

CAUTION: Belt tracking adjustments should be performed by trained personnel ONLY. Read section on "Belt Tracking" completely before attempting belt tracking adjustments.

***NOTE:** When making adjustments in direction "A" or direction "B", component must pivot from side "L" with actual component movement on side "R".

When adjustments noted in previous sections have been completed and belt continues to track erratically, a final series of tracking adjustments are necessary.

The following adjustments will be made referring to the direction of **belt flow** and not the **product flow** of the conveyor.

If belt tracks toward side "R" (see illustration above), skew return rollers in direc-

tion "B" to shift belting toward side "L". If belt tracks toward side "L", skew return rollers in direction "A" to shift belting toward side "R".

Skewing head pulley (pulley at unit discharge) in direction "A" moves belt toward side "L". Skewing head pulley in direction "B" moves belt toward side "R".

As a rule of thumb, do not use drive and take-up pulley for belt tracking since this will overly increase belt tension. When adjusting take-up pulley, adjust both sides an equal amount.

As a last resort, shift the tail pulley in direction "B" to move belting toward side "L"; shift head pulley in direction "A" to move belting toward side "L".

SETTING PRESSURE ROLLER TENSION CALR PRESSURE ROLLER ADJUSTMENT

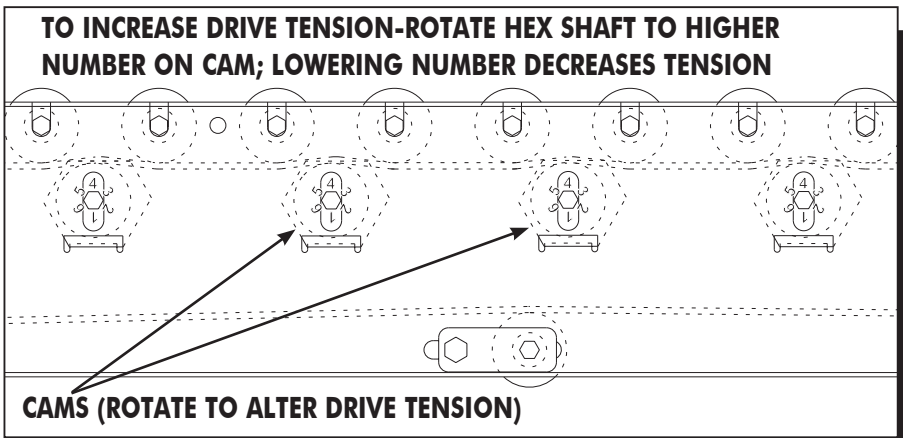

NOTE: Do not apply too much pressure to tread rollers. If too much tension is applied, tread rollers may have tendency to raise out of slotted frame.

Model CALR, cam adjusted live roller conveyor, is set up and operational at the factory prior to shipment with proper drive tension pre-set by Roach assembly personnel. The cam adjusted live roller features the quickest and most simple adjustment of drive tension on tread rollers.

The illustration above shows a typical numbered cam and CALR frame. The frame has openings where numbers on the cam are visible. Therefore, at a glance, the tread roller tension can be determined.

To readjust in field, return the cam on the pressure rollers to zero by rotating the shaft counterclockwise to reduce drive tension. For quick adjustment use a hex socket. Use a 5/16" for 638 CALR, a 7/16" for 796 CALR and an 11/16" for 251 CALR. Place heaviest package at infeed. Beginning at infeed, adjust cams by rotating shafts clockwise until package begins to move. Complete cam adjustment on entire unit for minimum drive tension required to convey.

NOTE: Apply adequate pressure to tread rollers to convey heaviest box on

conveyor. If too much tension is applied, tread rollers may have tendency to raise out of slotted frame.

NOTE: For quick adjustment use a hex socket:

- 638 CALR.....5-16"
- 796 CALR.....7/16"
- 251 CALR.....11/16"

MAINTENANCE SAFETY PRECAUTIONS BEFORE PERFORMING MAINTENANCE

CAUTION: Only trained personnel shall perform maintenance functions. Before maintenance operations are performed, conveyor must be shut "OFF" and disconnects locked in the "OFF" position to prevent unit from unauthorized start-up.

One of the most important guidelines for maximizing conveyor operation and personnel safety is to implement a regular maintenance schedule and train personnel on the appropriate needs of the specific unit.

Only trained personnel shall perform maintenance functions. Before maintenance operations are performed, conveyor must be shut "OFF" and disconnects locked in the "OFF" position to prevent unit from unauthorized start-up during maintenance. All personnel should be informed of the safety procedures associated with unit maintenance and performance.

Do not perform any work on conveyors or conveyor system while in operation unless it is impossible to otherwise conduct adjustment, lubrication or other maintenance function. Only experienced, trained personnel possessing advanced hazards-training should attempt such critical operations.

MAINTENANCE AND FOLLOW-UP DETAILS

CAUTION: Only trained personnel shall perform maintenance functions. When maintenance is completed, only authorized personnel shall be permitted to start conveyor following maintenance or other emergency shut-off.

While performing maintenance do not wear loose clothing. Immediately report any hazardous conditions-sharp edges, pinch (or nip) points or other conditions that may result when several manufacturers supply machinery which may create operating hazards.

When using mechanical aids such as hoists, cables, or cranes exercise extreme caution to prevent damage to conveyors or other integrated machinery which may create a working hazard when maintenance is completed and units are in operation.

Clean up any spilled lubricants or other materials used in the maintenance process or those which may be deposited during unit operation. Eliminating poor housekeeping practices increases unit efficiency while creating safer personnel working conditions.

After maintenance, conduct visual inspection to ensure that all safety devices and guards have been replaced. Confirm that all

units are clear of tools, debris or other items. Before starting conveyor, check condition of unit caution labels (see "CAUTION LABELS" at front of handbook). If labels have been destroyed or are not clearly legible, call 870.483.7631 to receive replacement labels. Placement of caution labels is critical to avoid unauthorized unit operation which may result in hazardous working conditions for all related personnel coming in contact with conveyor.

Warn personnel that conveyor is being prepared for start-up and to stay clear of unit. Do not start conveyor until all personnel are clear. When maintenance is completed, only authorized personnel shall be permitted to start conveyor following maintenance or other emergency shut-off.

MAINTENANCE AND LUBRICATION

PERIODIC MAINTENANCE SCHEDULE

MODEL NO. _____

WEEKLY RECOMMENDED MAINTENANCE SCHEDULE*	
COMPONENT	DETAIL OF MAINTENANCE
BEARINGS	Lubricate in dirty, dusty or moist-wet conditions
UNIT SAFETY CHECK	Confirm placement of all guards, warning labels & check for loose bolts, nip points & other hazards

MONTHLY RECOMMENDED MAINTENANCE SCHEDULE*	
COMPONENT	DETAIL OF MAINTENANCE
GEAR REDUCER	Check for leaks
V-BELT DRIVE BELT	Check for proper operating tension & overall wear
DRIVE SHEAVES	Check & re-tighten set screws & check for overall wear
PILLOW BLOCK/FLANGE BEARINGS	Lubricate (normal conditions)
DRIVE CHAIN	Check for proper operating tension & for overall wear & lubricate
DRIVE SPROCKETS	Check for overall wear & re-tighten set screws

PERIODIC RECOMMENDED MAINTENANCE SCHEDULE*	
COMPONENT	DETAIL OF MAINTENANCE
GEAR REDUCER	Check for leaks
DRIVE CHAIN	Clean (brush in solvent) & re-lubricate by applying lubricant to inside of chain with brush or spout can at 2000 hour intervals
MOTOR	Check & clear motor ventilation openings at 500 hour intervals Check misc. operating conditions (normal heat & noise)

*All charts are for guidelines in normal operating or 'as noted' conditions. Severe applications may warrant additional maintenance.

MAINTENANCE AND LUBRICATION

RECOMMENDED LUBRICANTS

MISC. LUBRICANTS	
LUBRICANT	BRAND/DESCRIPTION
General Purpose Grease (For -30°F to 300° operation)*	Shell Dolium R (Shell Oil Co.) (or Suitable equivalent)
For extreme Temperature Operation (-90°F to 350°F operation)*	Mobiltemp SHC-32 (Mobil Oil Corp.) (or suitable equivalent)
Washdown Application* (-30°F to 225°F operation) (May require special consideration -- consult factory)	Shell Alvania No. 3 (Shell Oil Co.) (or suitable equivalent)
General Purpose Oil	SAE 10; SAE 20 or SAE 30

***NOTE:** Temperatures listed indicate the nominal operational temperature for the specific **lubricant** listed. This does not imply that the bearing housing, seals or any other conveyor unit component is rated to operate in this specific temperature range or environment. 250°F is the maximum operating temperature for standard bearing lubricants and bearing components. Although various lubricants may enhance bearing operation, special-order bearings may be required to achieve optimal bearing performance. For additional information, consult factory.

TROUBLE SHOOTING AND REPLACEMENT PARTS

TROUBLE SHOOTING / SERIAL PLATE

TROUBLE SHOOTING		
TROUBLE	PROBABLE CAUSE	REMEDY
Motor & gear reducer running excessively hot, or hard to start	A. Frozen sprocket B. Overload C. Electrical	A. Check and inspect all sprockets and bearings. Replace sprockets failing to rotate or that are difficult to rotate. B. Reduce cause and/or increase motor horsepower. C. Check wiring and circuits, take ampere reading, replace motor if necessary.
Motor & gear reducer makes excessive noise	A. Damaged gears B. Faulty bearing	A. Replace unit. B. Replace bearing.
Drive chain, conveying chain or sprockets experience excessive wear	A. Excessive chain tension B. Sprockets misaligned C. Chain not lubricated D. Damaged sprocket or chain E. Misalignment of chain guard F. Dirty chain	A. Reduce chain tension. B. Realign with straight edge across sprocket faces. C. Lubricated chain with approved lubricant, wipe away excess lubricant. D. Replace Damaged Component. E. Adjust chain guard assembly as necessary. F. Clean thoroughly and lubricate with approved lubricant.
Drive chain, conveying chain or sprockets make excessive noise	A. Insufficient chain tension B. Chain not adequately lubricated C. Sprockets misaligned	A. Adjust chain tension. B. Lubricate chain with approved lubricant, wipe away excess lubricant. C. Realign sprockets with straight edge across sprocket faces.
Pulsating chain	A. Insufficient chain tension B. Misalignment of chain guard C. Overload	A. Adjust chain tension. B. Adjust chain guard assembly as necessary. C. Inspect for obstruction to or drag on conveyor.
Broken chain	A. Frozen bearing or sprocket shaft B. Worn or damaged chain C. Obstructed or jam	A. Inspect for damaged bearings, replace if necessary. Replace links as required. B. Replace chain as required. C. Remove obstruction to clear jam.
Tread roller(s) stalls or does not turn when loaded	A. Product overload B. Drive band broken C. Oily conditions D. Frozen roller bearing	A. Alter product loading to specified load rating. Consult factory. B. Replace drive band. C. Remove oil with recommended cleaner. D. Replace roller.
Sprocket loose on shaft	A. Loose set screws B. Worn or damaged key	A. Realign sprockets with straight edge and tighten set screws. B. Replace with new key.
Excessive slack in chain	A. Normal wear	A. Expect rapid chain growth in first two weeks of operation. Adjust chain tension as specified in the manual.

ORDERING REPLACEMENT PARTS

To order any replacement parts or when calling for assistance with any powered conveyor, **ALWAYS** provide the unit serial number. Shown at actual size, this is placed on the conveyor frame near the location of the drive assembly.



ROACH CONVEYORS
808 HIGHWAY 463
TRUMANN, AR 72472
TEL 870-483-7631

SERIAL NO. **123456**

To order replacement parts or add-on components, contact the Roach distributor who originally furnished the unit if possible. If this is not possible, contact the National Sales Office at 870-483-7631 for the name of the authorized Roach distributor in your area. Have unit model number and serial number **BEFORE** calling. Refer to unit drawings (in rear section of handbook) for part numbers if ordering replacement parts.

MODEL 638CALR

PARTS LIST FOR UNIT WITH 4" AND 8" END DRIVE

ITEM #	DESCRIPTION	ITEM #	DESCRIPTION
1	638 CALRI INTERMEDIATE BED SECTION	1	638CALRI INTERMEDIATE BED SECTION (CONT.)
2	138 Roller Adjustment Bracket	6	138G Roller (138F-BG-D)
3	Splice Plate	7	138G Pressure Roller (138F-BG-D)
4	Frame Cross Brace	8	Presser Roller Adjusting Cam
5	Bed Space Rod (Not Shown)	9	Side Channel
10	4" END DRIVE ASSEMBLY	10	8" END DRIVE ASSEMBLY
11	4" Drive Pulley	11	8" Drive Pulley
12	4" End Drive Plate Left Hand	12	8" End Drive Plate Left Hand
13	4" End Drive Plate Right Hand	13	8" End Drive Plate Right Hand
14	3 Hole Flange Bearing w/1-3/16" Bore (BRW04040)	14	4 Hole Flange Bearing w/1-7/16" Bore (BRW04070)
15	138G Grooved Rollers (138G-BF-D-G1A)	15	138G Grooved Rollers (138G-BF-D-G1A)
16	1/8" Dia. 9-1/2" Long Pyralthane Round Belt (VBW71373)	16	1/8" Dia. 9-1/2" Long Pyralthane Round Belt (VBW71373)
16	1/8" Dia. 12" Long Pyralthane Round Belt (VBW71374)	16	1/8" Dia. 12" Long Pyralthane Round Belt (VBW71374)
16	1/8" Dia. 14-1/2" Long Pyralthane Round Belt (VBW71375)	16	1/8" Dia. 14-1/2" Long Pyralthane Round Belt (VBW71375)
16	1/8" Dia. 19-3/4" Long Pyralthane Round Belt (VBW71376)	16	1/8" Dia. 19-3/4" Long Pyralthane Round Belt (VBW71376)
16	1/8" Dia. 11-1/4" Long Pyralthane Round Belt (VBW71377)	16	1/8" Dia. 11-1/4" Long Pyralthane Round Belt (VBW71377)
		17	Snub Roller Adjustment Bracket (Not Shown)
		18	25 1S Roller (Not Shown) (A20345BF)
		19	Snub Roller Belt Guard (Not Shown)
20	4" END TAKE-UP ASSEMBLY	20	4" END TAKE-UP ASSEMBLY (CONT.)
21	4" Take-Up Pulley	29	Take-Up Butt Coupling
22	4" Take-Up Plate	30	PVC-120 Belting
23	Take-Up Bearing Slide Angle	31	Reducer Push Plate Assembly
24	Take-Up Bearing Guide	32	Underneath Motor Base Plate
25	Take-Up Bearing Assembly Left Hand (A26255L)	33	Chain Guard Angle Mount
26	Take-Up Bearing Assembly Right Hand (A26255R)	34	End Drive Chain Guard Assembly
27	138G Grooved Rollers (138G-BF-D-G1A)	35	#50 (thru 1-1/2 HP) or #60 Roller Chain
28	1/8" Dia. 9-1/2" Long Pyralthane Round Belt (VBW71373)	36	Gear Reducer Drive Sprocket
28	1/8" Dia. 12" Long Pyralthane Round Belt (VBW71374)	37	Pulley Drive Sprocket
28	1/8" Dia. 14-1/2" Long Pyralthane Round Belt (VBW71375)	38	Gear Reducer
28	1/8" Dia. 19-3/4" Long Pyralthane Round Belt (VBW71376)	39	Motor
28	1/8" Dia. 11-1/4" Long Pyralthane Round Belt (VBW71377)		

Specify **Unit Serial Number** when ordering replacement parts to ensure proper allocation of components.

Recommended **Spare Parts** are shown in red. **Charted** are item no. and part description. When ordering use example below.

Example: Need a replacement 4" Drive Pulley for 638CALR 4" End Drive

Part No: SN 123456 - 11 - 4" Drive Pulley



ROACH CONVEYORS
888 HIGHWAY 465
TRUMAN, AR 72472
TEL. 870-483-7631

SERIAL NO. 123456

WARNING:
When installing **below** 7'-0" elevation, tread rollers must be designed to pop out. When installing at 7'-0" or **higher** elevation, tread rollers must **NOT** be allowed to pop out.

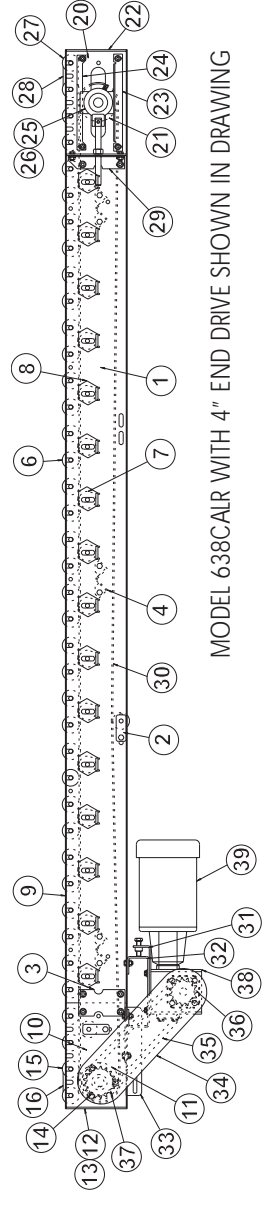

MODEL 638CALR WITH 4" END DRIVE SHOWN IN DRAWING

MODEL 638CALR

PARTS LIST FOR UNIT WITH 4" AND 8" CENTER DRIVE

Specify **Unit Serial Number** when ordering replacement parts to ensure proper allocation of components.
Recommended Spare Parts are shown in red. **Charted** are **item no.** and **part description**
 When ordering use example below.

Example: Need a replacement 4" Drive Pulley for 638CALR 4" Center Drive
 Part No: SN 123456 - 11 - 4" Drive Pulley



WARNING:
 When installing **below** 7'-0" elevation, tread rollers must be designed to pop out. When installing at 7'-0" or **higher** elevation, tread rollers must **NOT** be allowed to pop out.

ITEM #	DESCRIPTION	ITEM #	DESCRIPTION
1	638CALRI INTERMEDIATE BED SECTION	1	638CALRI INTERMEDIATE BED SECTION (CONT.)
2	138 Roller Adjustment Bracket	6	138G Roller (138F-BG-D)
3	Splice Plate	7	138G Pressure Roller (138F-BG-D)
4	Frame Cross Brace	8	Pressure Roller Adjusting Cam
5	Bed Space Rod (Not Shown)	9	Side Channel
10	4" CENTER DRIVE ASSEMBLY	10	8" CENTER DRIVE ASSEMBLY
11	4" Drive Pulley	11	8" Drive Pulley
12	4" Take-Up Pulley	12	4" Take-Up Pulley
13	4" Center Drive Plate Left Hand	13	8" Center Drive Plate Left Hand
14	4" Center Drive Plate Right Hand	14	8" Center Drive Plate Right Hand
15	4" Center Drive Belt Guard	15	8" Center Drive Belt Guard
16	4" Center Drive Belt Guard	16	8" Center Drive Belt Guard
17	Center Drive Take-Up Bearing Guide	17	Center Drive Take-Up Bearing Guide
18	Take-Up Bearing Assembly (A26231-L/R-SN)	18	Take-Up Bearing Assembly (A26231-L/R-SN)
19	3 Hole Flange Bearing w/1-3/16" Bore (BRW04040)	19	4 Hole Flange Bearing w/1-3/16" Bore (BRW04070)
20	251S Roller (A20345-BF)	20	251S Roller (A20345-BF)
21	Snub Roller Adjustment Bracket	21	Snub Roller Adjustment Bracket
22	4" FIXED END ASSEMBLY	22	4" FIXED END ASSEMBLY (CONT.)
23	4" Fixed End Pulley	28	6" Wide PVC-120 Belling
24	4" Fixed End Plate	29	Reducer Push Plate Assembly
25	138G Grooved Rollers (138G-BF-D-G1A)	30	Underneath Motor Base
26	3 Hole Flange Bearing w/1-3/16" Bore (BRW04040)	31	Chain Guard Angle Mount
27	1/8" Dia. 9-1/2" Long Pyranthane Round Belt (VBW71373)	32	Center Drive Chain Guard Assembly
27	1/8" Dia. 12" Long Pyranthane Round Belt (VBW71374)	33	#50 (thru 1-1/2 HP) or #60 Roller Chain
27	1/8" Dia. 14-1/2" Long Pyranthane Round Belt (VBW71375)	34	Gear Reducer Drive Sprocket
27	1/8" Dia. 19-3/4" Long Pyranthane Round Belt (VBW71376)	35	Pulley Drive Sprocket
27	1/8" Dia. 11-1/4" Long Pyranthane Round Belt (VBW71377)	36	Gear Reducer
		37	Motor

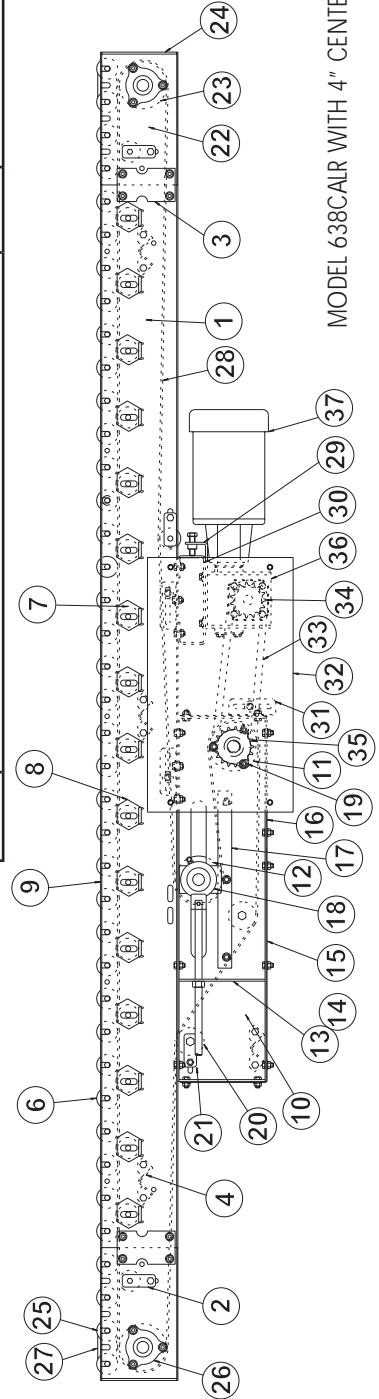

MODEL 638CALR WITH 4" CENTER DRIVE SHOWN IN DRAWING

MODEL 638CALR PARTS LIST FOR UNIT W/ 4" & 8" END SIDE MOUNT DRIVE

ITEM #	DESCRIPTION	ITEM #	DESCRIPTION
1	638CALRI INTERMEDIATE BED SECTION	1	638CALRI INTERMEDIATE BED SECTION (CONT.)
2	138 Roller Adjustment Bracket	6	138G Roller (138F-BG-D)
3	Splice Plate	7	138G Pressure Roller (138F-BG-D)
4	Frame Cross Brace	8	Pressure Roller Adjustment Cam
5	Bed Space Rod (Not Shown)	9	Side Channel
10	4" END DRIVE ASSEMBLY	10	8" END DRIVE ASSEMBLY
11	4" Drive Pulley	11	8" Drive Pulley
12	4" End Drive Plate Left Hand	12	8" End Drive Plate Left Hand
13	4" End Drive Plate Right Hand	13	8" End drive Plate Right Hand
14	3 Hole Flange Bearing w/1.3/16" Bore (BRW04040)	14	4 Hole Flange Bearing w/1.7/16" Bore (BRW04070)
15	138G Grooved Rollers (138G-BF-D-G1A)	15	138G Grooved Rollers (138G-BF-D-G1A)
16	1/8" Dia. 9.1/2" Long Pyrrathane Round Belt (VBW71373)	16	1/8" Dia. 9.1/2" Long Pyrrathane Round Belt (VBW71373)
16	1/8" Dia. 12" Long Pyrrathane Round Belt (VBW71374)	16	1/8" Dia. 12" Long Pyrrathane Round Belt (VBW71374)
16	1/8" Dia. 14-1/2" Long Pyrrathane Round Belt (VBW71375)	16	1/8" Dia. 14-1/2" Long Pyrrathane Round Belt (VBW71375)
16	1/8" Dia. 19-3/4" Long Pyrrathane Round Belt (VBW71376)	16	1/8" Dia. 19-3/4" Long Pyrrathane Round Belt (VBW71376)
16	1/8" Dia. 11-1/4" Long Pyrrathane Round Belt (VBW71377)	16	1/8" Dia. 11-1/4" Long Pyrrathane Round Belt (VBW71377)
		17	Snub Roller Adjustment Bracket
		18	251S Roller (A20345BF)
		19	Snub Roller Belt Guard
20	4" END TAKE-UP ASSEMBLY	19	4" END TAKE-UP ASSEMBLY (CONT.)
21	4" Take-Up Pulley	28	1/8" Dia. 11-1/4" Long Pyrrathane Round Belt (VBW71377)
22	4" Take-Up Plate	29	Take-Up Butt Coupling
23	Take-Up Bearing Slide Angle	30	PVC-120 Belling
24	Take-Up Bearing Guide	31	Reducer Push Plate Assembly
25	Take-Up Bearing Assembly Left Hand (A26255L)	32	Underneath Motor Base Plate
26	Take-Up Bearing Assembly Right Hand (A26255R)	33	End Drive Chain Guard Assembly
27	138G Grooved Rollers (138G-BF-D-G1A)	34	#50 (thru 1-1/2 HP) or #60 Roller Chain
28	1/8" Dia. 9.1/2" Long Pyrrathane Round Belt (VBW71373)	35	Gear Reducer Drive Sprocket
28	1/8" Dia. 12" Long Pyrrathane Round Belt (VBW71374)	36	Pulley Drive Sprocket
28	1/8" Dia. 14-1/2" Long Pyrrathane Round Belt (VBW71375)	37	Gear Reducer
28	1/8" Dia. 19-3/4" Long Pyrrathane Round Belt (VBW71376)	38	Motor

Specify **Unit Serial Number** when ordering replacement parts to ensure proper allocation of components. **Recommended Spare Parts are shown in red. Charted are item no. and part description** When ordering use example below.

Example: Need a replacement 4" Drive Pulley for 638CALR 4" End Side Mount Drive

Part No: SN 123456 - 11 - 4" Drive Pulley



WARNING:
When installing **below** 7'-0" elevation, tread rollers must be designed to pop out. When installing at 7'-0" or **higher** elevation, tread rollers must **NOT** be allowed to pop out.

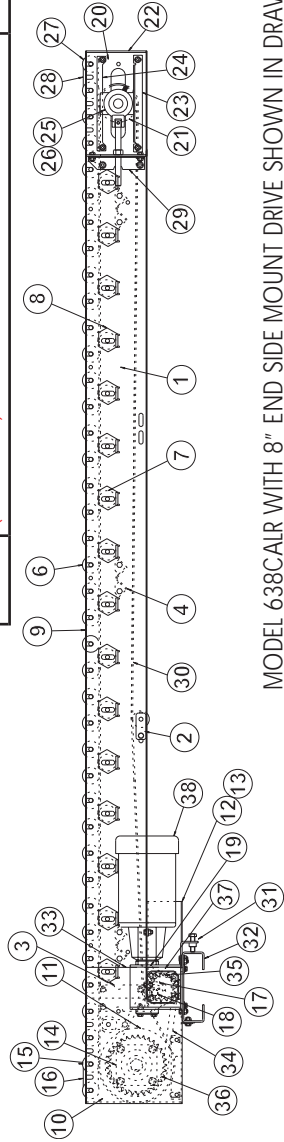

MODEL 638CALR WITH 8" END SIDE MOUNT DRIVE SHOWN IN DRAWING

MODEL 796CALR

PARTS LIST FOR UNIT W/ 4" & 8" END DRIVE

ITEM #	DESCRIPTION	ITEM #	DESCRIPTION
1	796CALR INTERMEDIATE BED SECTION	1	638CALR INTERMEDIATE BED SECTION (CONT.)
2	1.9 Roller Adjustment Bracket	6	196S Roller (A203040BF)
3	Splice Plate	7	196 Pressure Roller (A20314BF)
4	Frame Cross Brace	8	Presser Roller Adjusting Cam
5	Bed Space Rod (Not Shown)	9	Side Channel
10	4" END DRIVE ASSEMBLY	10	8" END DRIVE ASSEMBLY
11	4" Drive Pulley	11	8" Drive Pulley
12	4" End Drive Plate Left Hand	12	8" End Drive Plate Left Hand
13	4" End Drive Plate Right Hand	13	8" End drive Plate Right Hand
14	3 Hole Flange Bearing w/1.3/16" Bore (BRW04040)	14	4 Hole Flange Bearing w/1.7/16" Bore (BRW04070)
15	196S Grooved Roller (A37089BF)	15	196S Grooved Roller (A37089BF)
16	1/8" Dia. 9.1/2" Long Pyralthane Round Belt (VBW71373)	16	1/8" Dia. 9.1/2" Long Pyralthane Round Belt (VBW71373)
16	1/8" Dia. 12" Long Pyralthane Round Belt (VBW71374)	16	1/8" Dia. 12" Long Pyralthane Round Belt (VBW71374)
16	1/8" Dia. 14.1/2" Long Pyralthane Round Belt (VBW71375)	16	1/8" Dia. 14.1/2" Long Pyralthane Round Belt (VBW71375)
16	1/8" Dia. 19.3/4" Long Pyralthane Round Belt (VBW71376)	16	1/8" Dia. 19.3/4" Long Pyralthane Round Belt (VBW71376)
16	1/8" Dia. 11.1/4" Long Pyralthane Round Belt (VBW71377)	16	1/8" Dia. 11.1/4" Long Pyralthane Round Belt (VBW71377)
		17	Snub Roller Adjustment Bracket (Not Shown)
		18	251S Roller (Not Shown) (A20345BF)
		19	Snub Roller Belt Guard (Not Shown)
20	4" END TAKE-UP ASSEMBLY	20	4" END TAKE-UP ASSEMBLY (CONT.)
21	4" Take-Up Pulley	29	Take-Up Butt Coupling
22	4" Take-Up Plate	30	PVC-120 Belling
23	Take-Up Bearing Slide Angle	31	Reducer Push Plate Assembly
24	Take-Up Bearing Guide	32	Underneath Motor Base Plate
25	Take-Up Bearing Assembly Left Hand (A26255L)	33	Chain Guard Angle Mount
26	Take-Up Bearing Assembly Right Hand (A26255R)	34	End Drive Chain Guard Assembly
27	196S Grooved Roller (A37089BF)	35	#50 (thru 1.1/2 HP) or #60 Roller Chain
28	1/8" Dia. 9.1/2" Long Pyralthane Round Belt (VBW71373)	36	Gear Reducer Drive Sprocket
28	1/8" Dia. 12" Long Pyralthane Round Belt (VBW71374)	37	Pulley Drive Sprocket
28	1/8" Dia. 14.1/2" Long Pyralthane Round Belt (VBW71375)	38	Gear Reducer
28	1/8" Dia. 19.3/4" Long Pyralthane Round Belt (VBW71376)	39	Motor
28	1/8" Dia. 11.1/4" Long Pyralthane Round Belt (VBW71377)		

Specify **Unit Serial Number** when ordering replacement parts to ensure proper allocation of components.

Recommended Spare Parts are shown in red. **Charted** are item no. and part description. When ordering use example below.

Example: Need a replacement 4" Drive Pulley for 796CALR 4" End Drive

Part No: SN 123456 · 11 · 4" Drive Pulley



WARNING:
When installing **below 7'-0"** elevation, tread rollers must be designed to pop out. When installing at **7'-0"** or **higher** elevation, tread rollers must **NOT** be allowed to pop out.

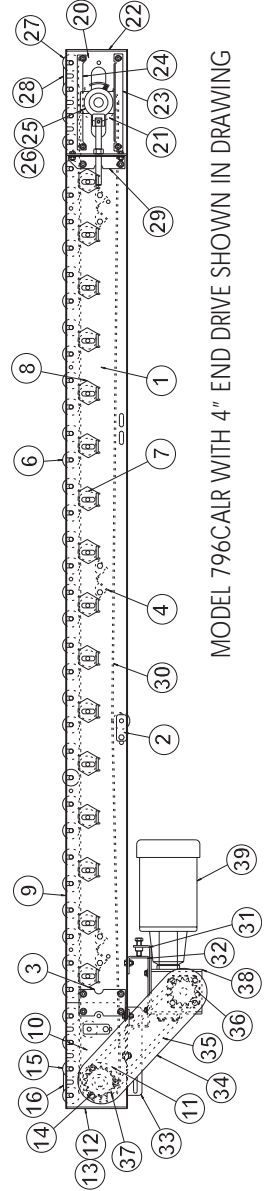

MODEL 796CALR WITH 4" END DRIVE SHOWN IN DRAWING

MODEL 796CALR

PARTS LIST FOR UNIT WITH 4" AND 8" CENTER DRIVE

ITEM #	DESCRIPTION	ITEM #	DESCRIPTION
1	796CALR INTERMEDIATE BED SECTION	1	796CALR INTERMEDIATE BED SECTION (CONT.)
2	1.9 Roller Adjustment Bracket	6	196 Roller (A203040-BF)
3	Splice Plate	7	196 Pressure Roller (A20314-BF)
4	Frame Cross Brace	8	Pressure Roller Adjusting Cam
5	Bed Space Rod (Not Shown)	9	Side Channel
10	4" CENTER DRIVE ASSEMBLY	10	8" CENTER DRIVE ASSEMBLY
11	4" Drive Pulley	11	8" Drive Pulley
12	4" Take-Up Pulley	12	4" Take-Up Pulley
13	4" Center Drive Plate Left Hand	13	8" Center Drive Plate Left Hand
14	4" Center Drive Plate Right Hand	14	8" Center Drive Plate Right Hand
15	4" Center Drive Belt Guard	15	8" Center Drive Belt Guard
16	4" Center Drive Belt Guard	16	8" Center Drive Belt Guard
17	Center Drive Take-Up Bearing Guide	17	Center Drive Take-Up Bearing Guide
18	Take-Up Bearing Assembly (A26231-L/R-SN)	18	Take-Up Bearing Assembly (A26231-L/R-SN)
19	3 Hole Flange Bearing w/1.3/16" Bore (BRW04040)	19	4 Hole Flange Bearing w/1.3/16" Bore (BRW04070)
20	251S Roller (A20345-BF)	20	251S Roller (A20345-BF)
21	Snub Roller Adjustment Bracket	21	Snub Roller Adjustment Bracket
22	4" FIXED END ASSEMBLY	22	4" FIXED END ASSEMBLY (CONT.)
23	4" Fixed End Pulley	28	6" Wide PVC-120 Belling
24	4" Fixed End Plate	29	Reducer Push Plate Assembly
25	196S Grooved Roller (A37089-BF)	30	Underneath Motor Base
26	3 Hole Flange Bearing w/1.3/16" Bore (BRW04040)	31	Chain Guard Angle Mount
27	1/8" Dia. 9-1/2" Long Pyranthane Round Belt (VBW71373)	32	Center Drive Chain Guard Assembly
27	1/8" Dia. 12" Long Pyranthane Round Belt (VBW71374)	33	#50 (thru 1-1/2 HP) or #60 Roller Chain
27	1/8" Dia. 14-1/2" Long Pyranthane Round Belt (VBW71375)	34	Gear Reducer Drive Sprocket
27	1/8" Dia. 19-3/4" Long Pyranthane Round Belt (VBW71376)	35	Pulley Drive Sprocket
27	1/8" Dia. 11-1/4" Long Pyranthane Round Belt (VBW71377)	36	Gear Reducer
		37	Motor

Specify **Unit Serial Number** when ordering replacement parts to ensure proper allocation of components.
Recommended Spare Parts are shown in red. Charted are item no. and part description
 When ordering use example below.

Example: Need a replacement 4" Drive Pulley for 796CALR 4" Center Drive
 Part No: SN 123456 - 11 - 4" Drive Pulley



WARNING:
 When installing **below** 7'-0" elevation, tread rollers must be designed to pop out. When installing at 7'-0" or **higher** elevation, tread rollers must **NOT** be allowed to pop out.

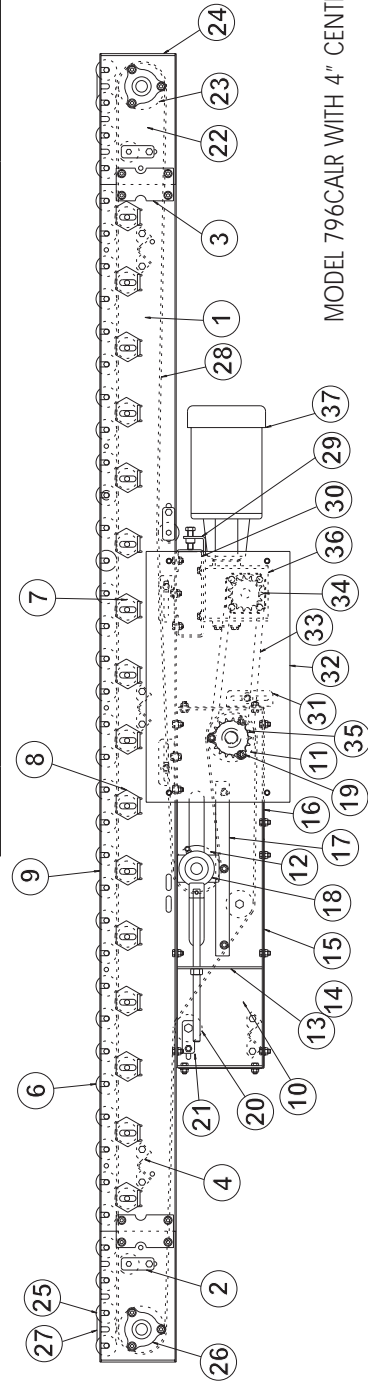

MODEL 796CALR WITH 4" CENTER DRIVE SHOWN IN DRAWING

MODEL 796CALR

PARTS LIST FOR UNIT W/ 4" & 8" END SIDE MOUNT DRIVE

ITEM #	DESCRIPTION	ITEM #	DESCRIPTION
1	796CALR INTERMEDIATE BED SECTION	1	796CALR INTERMEDIATE BED SECTION (CONT.)
2	1.9 Roller Adjustment Bracket	6	196S Roller (A20340-BF)
3	Splice Plate	7	196S Pressure Roller (A20314-BF)
4	Frame Cross Brace	8	Pressure Roller Adjustment Cam
5	Bed Space Rod (Not Shown)	9	Side Channel
10	4" END DRIVE ASSEMBLY	10	8" END DRIVE ASSEMBLY
11	4" Drive Pulley	11	8" Drive Pulley
12	4" End Drive Plate Left Hand	12	8" End Drive Plate Left Hand
13	4" End Drive Plate Right Hand	13	8" End drive Plate Right Hand
14	3 Hole Flange Bearing w/1-3/16" Bore (BRW04040)	14	4 Hole Flange Bearing w/1-7/16" Bore (BRW04070)
15	196S Grooved Roller (A37089-BF)	15	196S Grooved Roller (A37089-BF)
16	1/8" Dia. 9-1/2" Long Pyralthane Round Belt (VBW71373)	16	1/8" Dia. 9-1/2" Long Pyralthane Round Belt (VBW71373)
16	1/8" Dia. 12" Long Pyralthane Round Belt (VBW71374)	16	1/8" Dia. 12" Long Pyralthane Round Belt (VBW71374)
16	1/8" Dia. 14-1/2" Long Pyralthane Round Belt (VBW71375)	16	1/8" Dia. 14-1/2" Long Pyralthane Round Belt (VBW71375)
16	1/8" Dia. 19-3/4" Long Pyralthane Round Belt (VBW71376)	16	1/8" Dia. 19-3/4" Long Pyralthane Round Belt (VBW71376)
16	1/8" Dia. 11-1/4" Long Pyralthane Round Belt (VBW71377)	16	1/8" Dia. 11-1/4" Long Pyralthane Round Belt (VBW71377)
		17	Snub Roller Adjustment Bracket
		18	251S Roller (A20345-BF)
		19	Snub Roller Belt Guard
20	4" END TAKE-UP ASSEMBLY	19	4" END TAKE-UP ASSEMBLY (CONT.)
21	4" Take-Up Pulley	28	1/8" Dia. 11-1/4" Long Pyralthane Round Belt (VBW71377)
22	4" Take-Up Plate	29	Take-Up Butt Coupling
23	Take-Up Bearing Slide Angle	30	PVC-120 Belling
24	Take-Up Bearing Guide	31	Reducer Push Plate Assembly
25	Take-Up Bearing Assembly Left Hand (A26255L)	32	Underneath Motor Base Plate
26	Take-Up Bearing Assembly Right Hand (A26255R)	33	End Drive Chain Guard Assembly
27	196S Grooved Roller (A37089-BF)	34	#50 (thru 1-1/2 HP) or #60 Roller Chain
28	1/8" Dia. 9-1/2" Long Pyralthane Round Belt (VBW71373)	35	Gear Reducer Drive Sprocket
28	1/8" Dia. 12" Long Pyralthane Round Belt (VBW71374)	36	Pulley Drive Sprocket
28	1/8" Dia. 14-1/2" Long Pyralthane Round Belt (VBW71375)	37	Gear Reducer
28	1/8" Dia. 19-3/4" Long Pyralthane Round Belt (VBW71376)	38	Motor

Specify **Unit Serial Number** when ordering replacement parts to ensure proper allocation of components. **Recommended Spare Parts are shown in red. Charted are item no. and part description** When ordering use example below.

Example: Need a replacement 4" Drive Pulley for 796CALR 4" End Side Mount Drive

Part No: SN 123456 · 11 · 4" Drive Pulley



WARNING: When installing **below** 7'-0" elevation, tread rollers must be designed to pop out. When installing at 7'-0" or **higher** elevation, tread rollers must **NOT** be allowed to pop out.

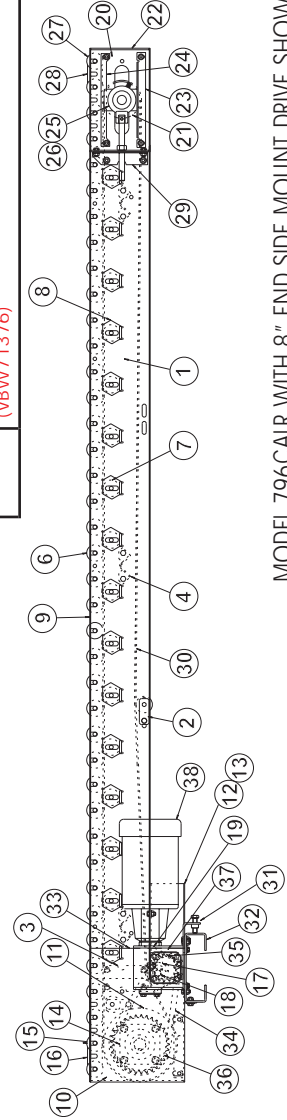

MODEL 796CALR WITH 8" END SIDE MOUNT DRIVE SHOWN IN DRAWING

MODEL 251CALR PARTS LIST FOR UNIT WITH 8" AND 12" END DRIVE

ITEM #	DESCRIPTION	ITEM #	DESCRIPTION
1	251CALR INTERMEDIATE BED SECTION	1	251CALR INTERMEDIATE BED SECTION (CONT.)
2	1.9 Roller Adjustment Bracket	7	251CALR Cross Brace Pipe
3	Splice Plate	8	251 CALR Cross Member
4	251 CALR Cross Brace Rod	9	196S Pressure Roller (A20314-BF)
5	Pressure Roller Adjusting Cam	10	196S Rollers (A20340-BF)
6	251S Roller (A20345-BF)	11	Side Channel
12	8" END DRIVE ASSEMBLY	12	12" END DRIVE ASSEMBLY
13	8" Drive Pulley	13	12" Drive Pulley
14	8" End Drive Plate	14	12" End Drive Plate
15	4 Hole Flange Bearing w/1-7/16" Bore (BRW04070)	15	4 Hole Flange Bearing w/1-15/16" Bore (BRW04080)
16	251S Roller (Snub Roller) (A20345-BF)	16	251S Roller (Snub Roller) (A20345-BF)
17	Snub Roller Adjustment Bracket	17	Snub Roller Adjustment Bracket
18	Snub Roller Belt Guard	18	Snub Roller Belt Guard
19	1.9 Roller Adjustment Bracket	19	1.9 Roller Adjustment Bracket
20	4" END TAKE-UP ASSEMBLY	20	6" END TAKE-UP ASSEMBLY
21	4" Take-Up Pulley	21	6" Take-Up Pulley
22	4" Take-Up Plate	22	6" Take-Up Plate
23	251CALR Take-Up Bearing Slide Angle	23	Nylon Brg. Guide Space & Washer (Not Shown)
24	251 CALR Take-Up Bearing Guide	24	251 CALR Take-Up Bearing Guide
25	Take-Up Bearing Assembly (Milled) (A26255L/R-SN)	25	Take-Up Bearing Assembly w/1-7/16" Bore (A26254-SN)
26	251CALR Take-Up Splice Plate	26	251CALR Take-Up Splice Plate
		27	Snub Roller Adjustment Bracket (Not Shown)
		28	251S Snub Roller (Not Shown) (A20345-BF)
		29	Snub Roller Belt Guard (Not Shown)
30	PVC-120 Belling	35	#50 (thru 1-1/2 HP) or #60 Roller Chain
31	Reducer Push Plate Assembly	36	Gear Reducer Drive Sprocket
32	Underneath Motor Base Plate	37	Pulley Drive Sprocket
33	Chain Guard Angle Mount	38	Gear Reducer
34	End Drive Chain Guard Assembly	39	Motor

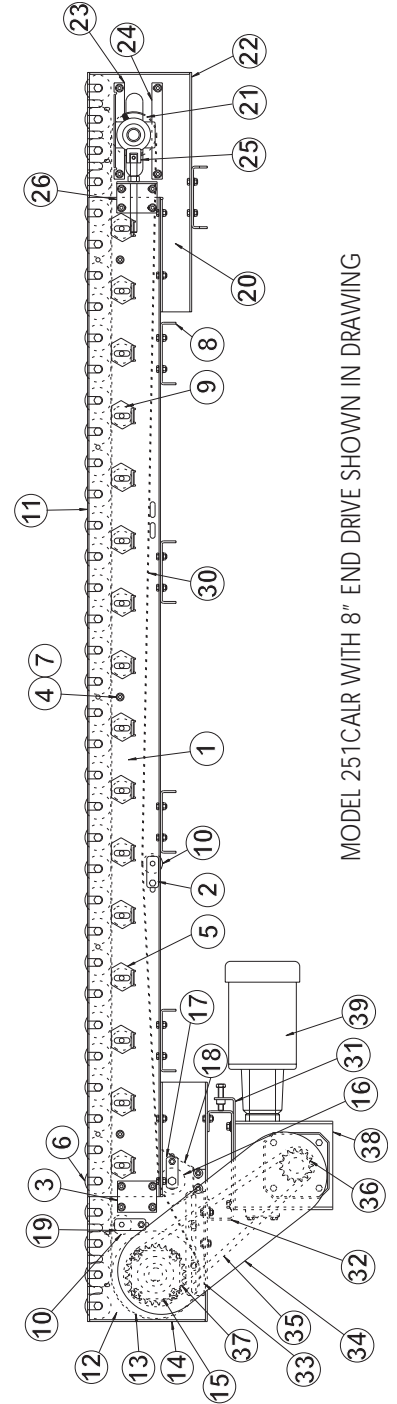

MODEL 251CALR WITH 8" END DRIVE SHOWN IN DRAWING

Specify **Unit Serial Number** when ordering replacement parts to ensure proper allocation of components. **Recommended Spare Parts are shown in red. Charted are item no. and part description** When ordering use example below.

Example: Need a replacement 12" Drive Pulley for 251CALR 12" End Drive

Part No: SN 123456 - 13 - 12" Drive Pulley



WARNING:
When installing **below 7'-0"** elevation, tread rollers must be designed to pop out. When installing at **7'-0"** or **higher** elevation, tread rollers must **NOT** be allowed to pop out.

MODEL 251CALR PARTS LIST FOR UNIT WITH 8" AND 12" CENTER DRIVE

ITEM #	DESCRIPTION	ITEM #	DESCRIPTION
1	251CALRI INTERMEDIATE BED SECTION	1	251CALRI INTERMEDIATE BED SECTION (CONT.)
2	1.9 Roller Adjustment Bracket	7	251CALR Cross Brace Pipe
3	Splice Plate	8	251 CALR Cross Member
4	251 CALR Cross Brace Rod	9	196S Pressure Roller (A20314-BF)
5	Pressure Roller Adjusting Cam	10	196S Rollers (A20340-BF)
6	251S Roller (A20345-BF)	11	Side Channel
12	8" CENTER DRIVE ASSEMBLY	12	12" CENTER DRIVE ASSEMBLY
13	8" Drive Pulley	13	12" Drive Pulley
14	4" Take-Up Pulley	14	Take-Up Pulley (For 6" Take-Up Only)
15	8" Center Drive Plate	14	Take-Up Pulley (For 8" Take-Up Only)
16	Frame Cross Brace	15	12" Center Drive Plate
17	4 Hole Flange Bearing w/1-7/16" Bore (BRW04070)	16	Frame Cross Brace
18	Center Drive Take-Up Bearing Guide	17	4 Hole Flange Bearing w/1-15/16" Bore (BRW04080)
19	Take-Up Bearing Assembly (Milled) (A26231-L/R-SN)	18	Center Drive Take-Up Bearing Guide
20	8" Center Drive Belt Guard	19	Take-Up Bearing Assembly (4" T-U Only) (A26231-L/R-SN)
21	8" Center Drive Belt Guard	19	Take-Up Bearing Assem. (6" & 8" T-U Only)(A26253-SN)
22	251S Roller (A20345-BF)	20	12" Center Drive Belt Guard
23	Snub Roller Adjustment Bracket	21	12" Center Drive Belt Guard
		22	4" Snub Pulley (Not Shown)
		23	3 Hole Flg. Brg. 1-3/16" Bore (Not Shown) (BRW04040)
		24	Bearing Push Plate (Not Shown)
25	4" FIXED END ASSEMBLY	25	6", 8" FIXED END ASSEMBLY
26	4" Fixed End Pulley	26	6" Fixed End Pulley
27	4" Fixed End Plate	26	8" Fixed End Pulley
28	3 Hole Flange Bearing w/1-3/16" Bore (BRW04040)	27	6" Fixed End Plate
29	1.9 Roller Adjustment Bracket	27	8" Fixed End Plate
30	196S Roller (A20340-BF)	28	4 Hole Flange Bearing w/1-7/16" Bore (BRW04070)
		29	1.9 Roller Adjustment Bracket
		30	196S Roller (A20340-BF)
		31	251S Snub Roller (6", 8" Pulley; Not Shown)(A20345-BF)
		32	Snub Roller Adj. Bracket (6", 8" Pulley; Not Shown)
		33	Snub Roller Adj. Belt Guard (6", 8" Pulley; Not Shown)
34	PVC-120 Belting	39	Gear Reducer Drive Sprocket
35	Reducer Push Plate	40	Pulley Drive Sprocket
36	Underneath Motor Base Plate	41	Gear Reducer
37	Center Drive Chain Guard Assembly	42	Motor
38	#50 (thru 1-1/2 HP) or 60# Roller Chain		

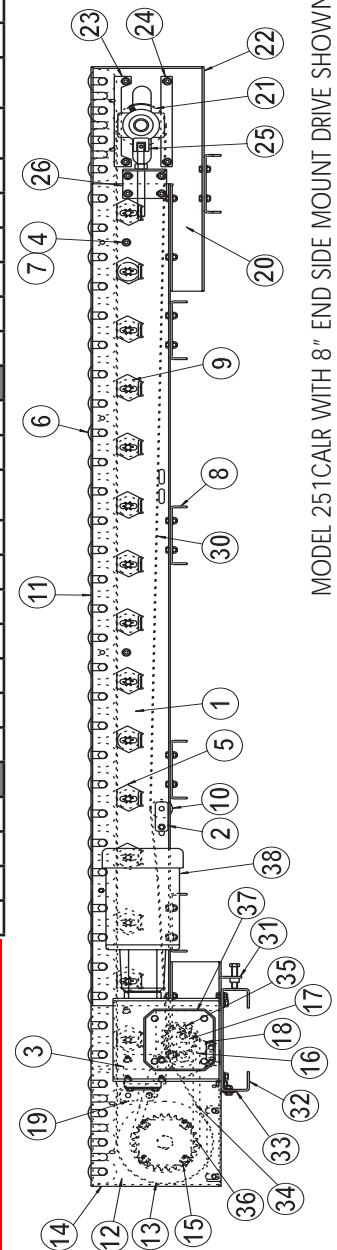

MODEL 251CALR WITH 8" END SIDE MOUNT DRIVE SHOWN IN DRAWING

Specify **Unit Serial Number** when ordering replacement parts to ensure proper allocation of components.

Recommended Spare Parts are shown in red. Charted are item no. and part description

When ordering use example below.

Example: Need a 8" Drive Pulley for 251 CALR 8" Center Drive

Part No:SN 123456 - 13 - 8" Drive Pulley

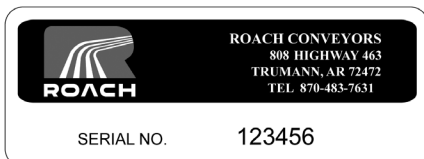

WARNING:

When installing **below 7'-0"** elevation, tread rollers must be designed to pop out.

When installing at **7'-0"** or **higher** elevation, tread rollers must **NOT** be allowed to pop out.

MODEL 251CALR

PARTS LIST FOR UNIT w/ 8" & 12" END SIDE MOUNT DRIVE

Specify **Unit Serial Number** when ordering replacement parts to ensure proper allocation of components.
Recommended Spare Parts are shown in red. Charted are item no. and part description
 When ordering use example below.

Example: Need a replacement 8" Drive Pulley for 251 CALR 8" End Side Mount Drive

Part No: SN 123456 - 13 - 8" Drive Pulley



WARNING:
 When installing **below 7'-0"** elevation, tread rollers must be designed to pop out. When installing at **7'-0"** or **higher** elevation, tread rollers must **NOT** be allowed to pop out.

ITEM #	DESCRIPTION	ITEM #	DESCRIPTION
1	251CALR INTERMEDIATE BED SECTION	1	251CALR INTERMEDIATE BED SECTION (CONT.)
2	1.9 Roller Adjustment Bracket	7	251CALR Cross Brace Pipe
3	Splice Plate	8	251 CALR Cross Member
4	251 CALR Cross Brace Rod	9	196S Pressure Roller (A20314-BF)
5	Pressure Roller Adjusting Cam	10	196S Rollers (A20340-BF)
6	251S Roller (A20345-BF)	11	Side Channel
12	8" END DRIVE ASSEMBLY	12	12" END DRIVE ASSEMBLY
13	8" Drive Pulley	13	12" Drive Pulley
14	8" End Drive Plate	14	12" End Drive Plate
15	4 Hole Flange Bearing w/1-7/16" Bore (BRW04070)	15	4 Hole Flange Bearing w/1-15/16" Bore (BRW04080)
16	251S Roller (Snub Roller) (A20345-BF)	16	251S Roller (Snub Roller) (A20345-BF)
17	Snub Roller Adjustment Bracket	17	Snub Roller Adjustment Bracket
18	Snub Roller Belt Guard	18	Snub Roller Belt Guard
19	1.9 Roller Adjustment Bracket	19	1.9 Roller Adjustment Bracket
20	4" END TAKE-UP ASSEMBLY	20	6" END TAKE-UP ASSEMBLY
21	4" Take-Up Pulley	21	6" Take-Up Pulley
22	4" Take-Up Pulley	22	6" Take-Up Plate
23	251CALR Take-Up Bearing Slide Angle	23	Nylon Brg. Guide Space & Washer (Not Shown)
24	251CALR Take-Up Bearing Guide	24	251CALR Take-Up Bearing Guide
25	Take-Up Bearing Assembly (Milled) (A26255L/RSSN)	25	Take-Up Bearing Assembly w/1-7/16" Bore (A26254-SN)
26	251CALR Take-Up Splice Plate	26	251CALR Take-Up Splice Plate
		27	Snub Roller Adjustment Bracket (Not Shown)
		28	251S Snub Roller (Not Shown) (A20345-BF)
		29	Snub Roller Belt Guard (Not Shown)
30	PVC-120 Belting	35	Gear Reducer Drive Sprocket
31	Reducer Push Plate Assembly	36	Pulley Drive Sprocket
32	Side Mount Motor Base Plate	37	Gear Reducer
33	Side Mount Chain Guard Assembly	38	Motor
34	#50 (thru 1-1/2 HP) or 60# Roller Chain		

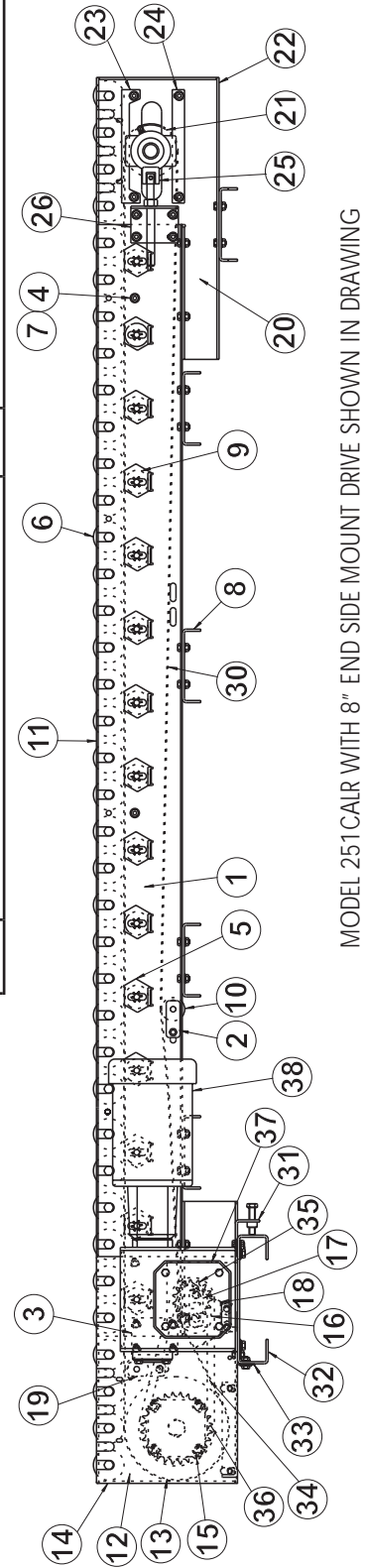

MODEL 251CALR WITH 8" END SIDE MOUNT DRIVE SHOWN IN DRAWING



ROACH CONVEYORS

WARRANTY

- Materials used by Roach Conveyors are of good quality.
- Any part proving to be defective in materials or workmanship upon Roach inspection, will be replaced at NO cost, FOB, Trumann, Arkansas, for one year. Installation expense will be paid by others.
- Roach liability includes furnishing said part or parts; Roach is not liable for consequential damages, such as loss of profit, delays or expenses incurred by failure of said part or parts.
- Failure due to abuse, incorrect adjustments, exposure to corrosive or abrasive environment or operation under damp conditions does not constitute failure due to defects in workmanship or materials.
- Component parts not manufactured by Roach (motors, gear reducers, etc.) will be repaired or replaced at the option of their manufacturer. Contact nearest authorized service center for all warranty claims.

NOTE: Motors or gear reducers tampered with before inspection shall be considered free of ALL Warranty Claims.

--All specifications are subject to change without notice--
--Drawings are intended for illustration ONLY and are not to scale--



ROACH
C O N V E Y O R S ®

808 HIGHWAY 463
TRUMANN, ARKANSAS 72472-1310
Tel 870-483-7631 Fax 870-483-7049
info@roachconveyors.com
www.roachconveyors.com