

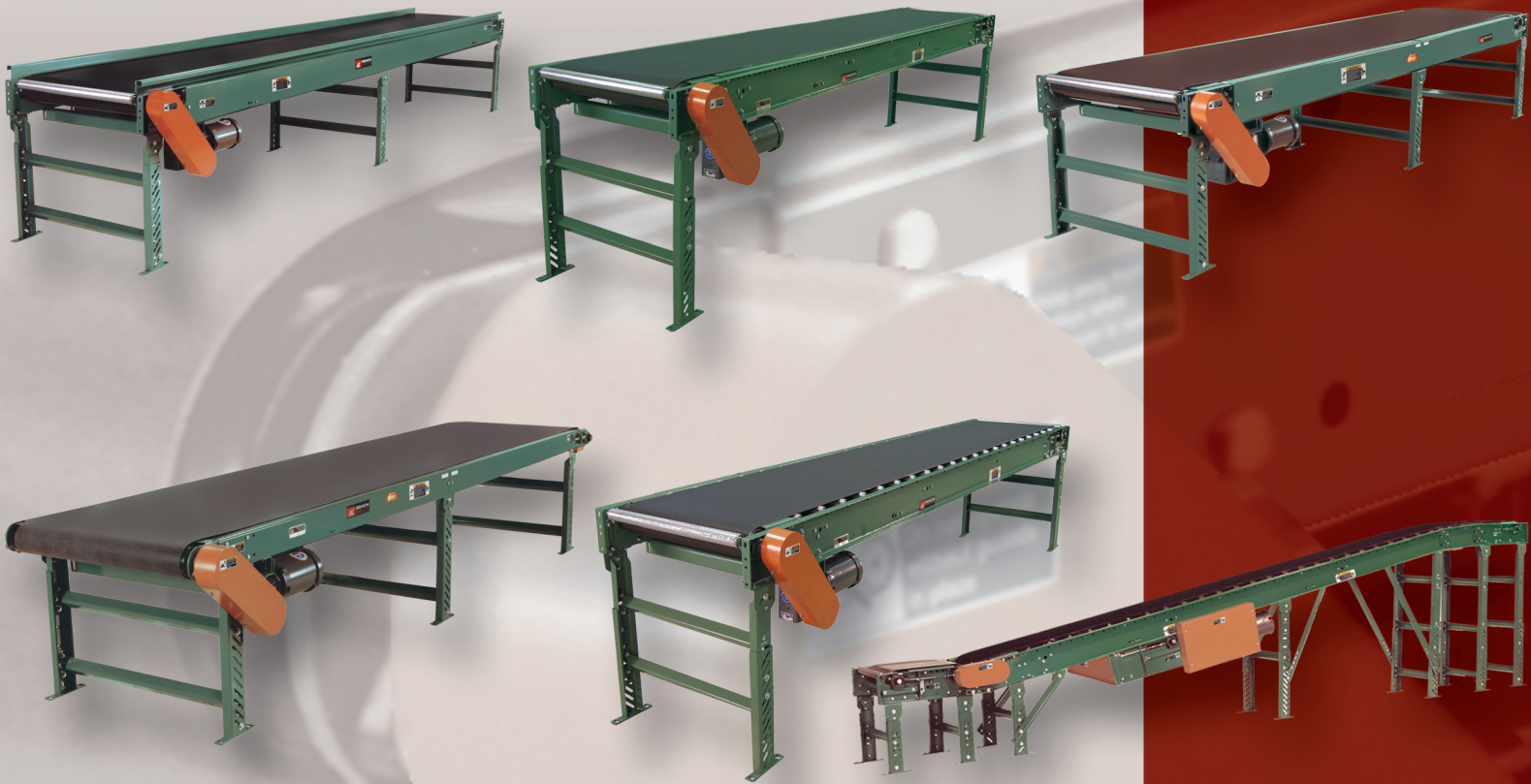

# OWNER'S MANUAL



## Belt Conveyors

Model 725TB • 700SB • 700BSB • 450BOS  
796RB • 751RB • 796RBF • 700SBF

DO NOT OPERATE BEFORE READING THIS HANDBOOK  
KEEP IN A SAFE PLACE – DO NOT DISCARD

# TECH HANDBOOK FOR 725TB/700SB/700BSB/450BOS 796RB/751RB/796RBF/700SBF

-Warning Labels .....	2	<b>BELT TRACKING</b> .....	10	<b>PARTS LISTS FOR 700BSB</b> .....	20
<b>CAUTIONS, WARNINGS AND HAZARDS</b> .....	3	-General Information .....	10	-Parts List .....	20
-Important Safety Guidelines .....	3	-Skewing Return Rollers .....	10	-Drawings .....	21
<b>RECEIVING AND INSPECTION</b> .....	4	-Erratic Tracking at Start-Up .....	10	<b>PARTS LISTS FOR 450BOS</b> .....	22
-Shortages, Damages & Return Auth .....	4	-Advanced Tracking Adjustments .....	10	-Parts List .....	22
-Uncrating and Storage .....	4	<b>MAINTENANCE SAFETY PRECAUTIONS</b> .....	11	-Drawings .....	23
-Safety Popout Roller Standard .....	4	-Before Performing Maintenance .....	11	<b>PARTS LISTS FOR 796RB</b> .....	24
<b>GENERAL INSTALLATION INFORMATION</b> .....	5	-Maintenance and Follow-Up Details .....	11	-Parts List .....	24-25
-Attaching Bed Sections .....	5	-Periodic Maintenance Schedule .....	11	-Drawings .....	26
-Couplings and Unit Squareness .....	5	-Misc. Lubricants .....	11	<b>PARTS LISTS FOR 751RB</b> .....	27
-Safety Connector Brackets (How to Order) .....	5	-Report on Miscellaneous Maint Performed .....	11	-Parts List .....	27-28
<b>INSTALLATION OF SUPPORTS</b> .....	-Identifying/ Installing Perm. Floor Supports .....	<b>BELT PATH</b> .....	12	-Drawings .....	29
-Installing Knee braces and Casters .....	6	-Illustrations for Units with End Drive .....	12	<b>PARTS LISTS FOR 796RBF</b> .....	30
<b>POLYTIER SUPPORTS, CEILING HANGERS AND UNDERTRUSSING</b> .....	7	-Illustrations for Units with Center Drive .....	12	-Parts List .....	30-31
-Installation of Polytier Supports .....	7	<b>BELT PATH</b> .....	13	-Drawings .....	32
-Installation of Ceiling Hangers .....	7	-Illustrations for Incline Units with End Drive .....	13	<b>PARTS LISTS FOR 700SBF</b> .....	33
-Installation of Undertrussing .....	7	-Illustrations for Incline Units with Center Drive .....	13	-Parts List .....	33-34
<b>INSTALLATION OF BELTING</b> .....	8	<b>MAINTENANCE AND LUBRICATION</b> .....	14	-Drawings .....	35
-Belt Connections .....	8	<b>TROUBLE SHOOTING &amp; REPLACEMENT PARTS</b> .....	15	<b>PARTS LISTS FOR INTEGRAL FEEDERS</b> .....	36
-Maintaining Proper Belt Tension .....	8	-Trouble Shooting / Serial Plate .....	15	-Parts List .....	36
-Nose-Over & Snub Roller Guard Adj .....	8	<b>PARTS LISTS FOR 725TB</b> .....	16	-Drawings .....	37
<b>START-UP PROCEDURES</b> .....	9	-Parts List .....	16	<b>PARTS LISTS FOR CHAIN DRIVEN FEEDERS</b> .....	38
-Drive Chain and Sprocket Alignment .....	9	-Drawings .....	17	-Parts List .....	38
-Drive Chain and Sprocket Tension .....	9	<b>PARTS LISTS FOR 700SB</b> .....	18	-Drawings .....	39
-Gear Reducer with Posivent Plug .....	9	-Parts List .....	18	<b>WARRANTY</b> .....	40
-Preparing for Initial Start-Up .....	9	-Drawings .....	19		

## WARNING LABELS



ABOVE: Label attached to all protective guards (drives, roller guards, etc.)



ABOVE: Label placed near all pulleys (center drives, end drives, tail pulleys)

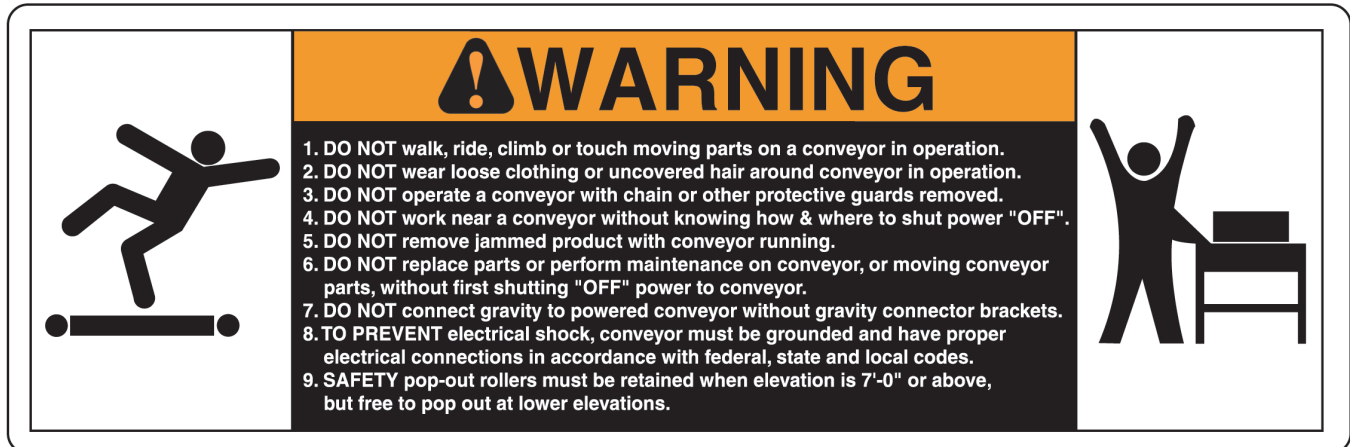

ABOVE: Label placed near all drive assemblies and at 30' intervals

# WARNING

## DO NOT OPERATE BEFORE READING THIS MANUAL! KEEP IN SAFE PLACE--DO NOT DISCARD!

This manual was prepared as a "how-to-guide" for installers, end-users and maintenance personnel. It is also intended to educate both owner (purchaser) and all individuals working around the unit, of potential hazards.

Conveyors contain many moving parts--pulleys, belting, chains, sprockets, shafts, rollers, etc. Therefore, it is imperative to become familiar with basic unit operation and know all points of potential hazards.

This manual must be read by all new users before operating or working near this unit.

### CAUTIONS, WARNINGS AND HAZARDS

NEVER connect belt conveyors directly to gravity conveyors, machinery or fixtures without using connector brackets & pop out roller.

ALWAYS anchor permanent supports to floor (or mounting surface). Use 3/8" x 2-1/2" (or longer) wedge anchors for permanent installation in concrete flooring.

It is the responsibility of the customer and installation personnel to supply and install net or mesh guarding on overhead mounted conveyors to prevent product and/or debris from falling to floor in areas where required.

If belt conveyor pulleys are adjusted during installation or maintenance, nip point guard (at drive end on end drive unit) must be readjusted. Nip point guard (take-up end) is automatically adjusted when take-up pulley is adjusted. Nip point guards at both ends of conveyor (center drive) must be readjusted. Center drive guards MUST be replaced after installation or maintenance.

Before unit is ready for operation, snub roller guard (cover) must be adjusted to ensure safe unit operation.

Belt lacing must be kept in good condition for safe work environment.

To check drive sprocket alignment, shut "OFF" and lock out power source before attempting any adjustments.

Electrical controls must be designed by a qualified electrical engineer to ensure that appropriate safety features (emergency stops, pull cords, switches, etc.) are installed on unit for safe operation. Before conveyor start-up, all operators and other personnel coming in contact with unit must be properly trained and must have read accompanying Tech Handbook.

Upon start-up, if belt tracks to one side, turn unit "OFF", lock out power source and confirm that conveyor is square and that all prime tracking components are square with bed. Belt tracking adjustments should be performed by trained personnel ONLY. Read section on "Belt Tracking" completely before attempting belt tracking adjustments.

Only trained personnel shall perform maintenance functions. Before maintenance operations are performed, shut conveyor "OFF" and lock out power source to prevent unauthorized start-up. When maintenance is completed, only authorized personnel shall be permitted to start conveyor following maintenance or other emergency shut-off.

### IMPORTANT SAFETY GUIDELINES

Warning: All personnel coming in contact with this conveyor should be aware of the following safety guidelines BEFORE USING OR WORKING AROUND CONVEYOR.

Note: always notify Roach Manufacturing® whenever any conveyor is used in an application or condition other than was originally intended. Failure to notify Roach® may allow conveyor to be operated in a hazardous operating condition. Injuries resulting from negligence or violation of safety instructions hereby removes responsibility of product liability claims from Roach®.

Do not operate conveyor with protective guards removed. This includes chain guards, belt guards, snub roller guards, center drive guards and any other safety guard.

Do not walk, ride, climb, or touch moving parts on a conveyor in operation.

Do not wear loose clothing or uncovered hair around conveyor.

Do not work near conveyor without knowing how & where to shut power "OFF" and lock out power source.

Do not remove jammed product with conveyor running.

Do not replace parts or perform maintenance on conveyor, or moving conveyor parts, without first shutting "OFF" power to conveyor and locking out power source.

Do not connect gravity to powered conveyor without safety gravity connector brackets.

To prevent electrical shock, conveyor must be grounded, and have proper electrical connections in accordance with federal, state, and local codes.

Safety pop out rollers in conveyors installed above 7'-0" elevation must be retained by guard rail, clips, etc. Safety pop out rollers must be allowed to pop out when conveyors are installed at or below 7'-0" elevation.

It is the responsibility of conveyor end-user to comply with all safety standards including OSHA and other federal, state, and local codes or regulations. Install protective guarding and other related safety precautionary equipment to eliminate hazardous operating conditions which may exist when two or more vendors supply machinery for related use.

Any violation of above safety instructions hereby removes all product liability claims from Roach Manufacturing Corporation®.

# RECEIVING AND INSPECTION SHORTAGES, DAMAGES AND RETURN AUTHORIZATIONS

- Before uncrating, check the quantity of items received against bill of lading to confirm that all material has been received. Examine the condition of the equipment to determine if any damage has occurred.
- It is possible that some items may become separated from the original shipment. Therefore, when receiving goods, it is imperative that the bill of lading (or, accompanying freight documentation) be checked to ensure receipt of ALL units ordered including ALL accessories.
- Damage and/or shortage in shipment should be reported immediately to both vendor and carrier. Obtain a signed damage report from carrier agent and send copy to vendor.  
Do not repair any damage before obtaining this report.

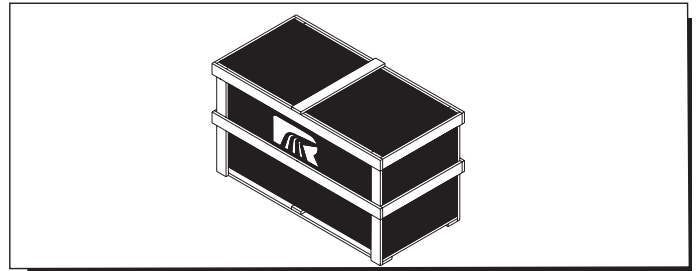

- For damaged shipments, consult factory to determine if entire shipment must be returned to factory for repair or if an immediate order should enter production to produce a new, replacement shipment.

**Note:** Do not return goods to factory without prior, written return authorization. Unauthorized returns are subject to refusal at factory.

## UNCRATING AND STORAGE

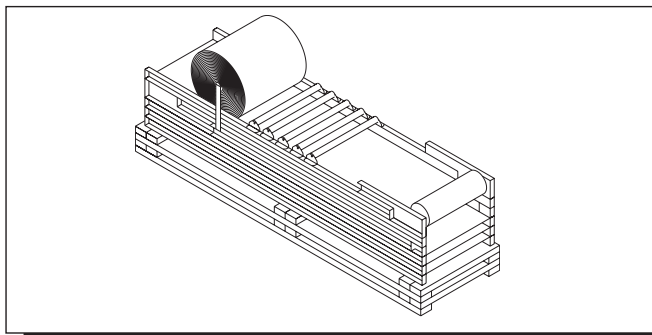

- Carefully remove crating and look for essential components and specific accessories that may have been boxed and attached (or 'banded') to crating material. Safety pop out rollers, guard rails and hardware are often packaged and shipped in this manner. Save all hardware for subsequent use by installation personnel.
- The drive section will be shipped mounted to its actual operating bed section (see illustration above). Intermediate bed sections are shipped mounted on top of drive bed section with formed steel stiffener (spacer) brackets.

- In illustration to the left, a model 700SB is shown palletized with belting and return rollers for all bed sections mounted to top of crate which is prepared for shipment.
- Some items (electric motors, gearbox, etc.) may be shipped direct from their manufacturer to final destination. Thus, the conveyor may consist of two or more separate shipments.
- Belting must be housed in dry quarters. Do not store belt on edge (see illustration below).

- Never Store belt placed directly on floor. Elevate to prevent contact with floor moisture.

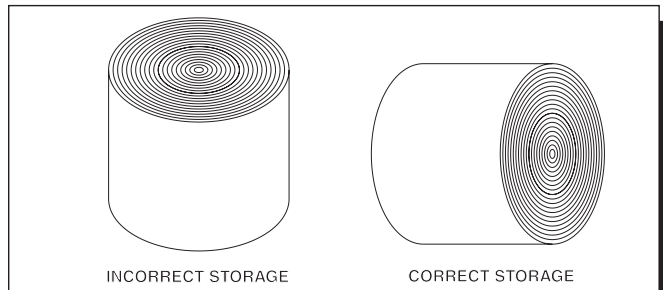

## SAFETY POPOUT ROLLER STANDARD

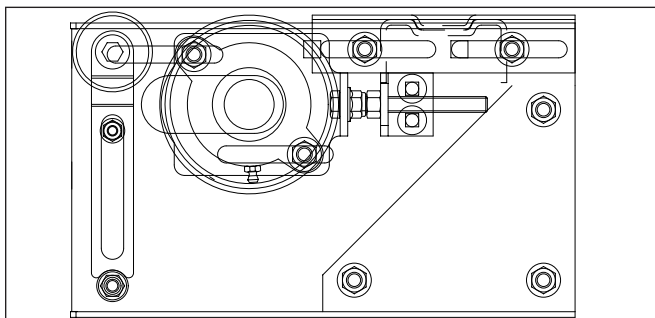

Always leave popout roller (see illustration at left) in place when permanently attaching any gravity conveyor to power conveyor. Never connect powered belt conveyors directly to gravity conveyors without using the pop out roller.

**Never connect power belt conveyors to any other conveyor or equipment without the safety popout roller in place as shown at left.**

# GENERAL INSTALLATION INFORMATION

## ATTACHING BED SECTIONS

When preparing to install conveyor:

- **Locate all component sections** in the actual installation area.
- **After uncrating, place unit bed sections conveying side up.** Each bed section is marked to indicate proper sequence for mating (see illustration for typical bed section labels).
- **It is critical for bed sections to be field assembled in proper sequence following bed section labels. Refer to bed section drawing for location of supports and assemble as shown.**
- **Conveyors are set up at the factory,** bed section labels are applied, unit is test run and receives rigorous quality assurance inspection. At this time the unit becomes field-ready. Therefore, it is critical that field installation personnel re-assemble unit by mating beds in accordance with bed section labels (and bed section drawing).

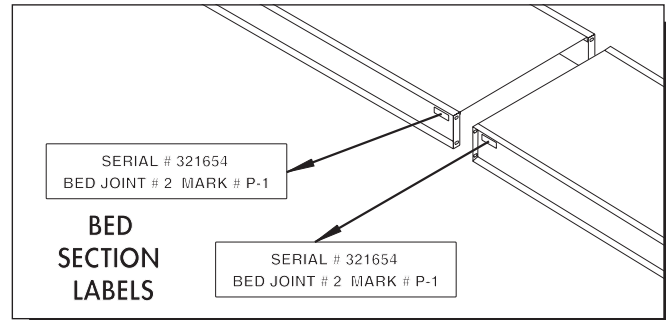

- **Create a reference base line on floor** by marking a chalk line along the center line of conveyor. Follow base line when installing unit.

## COUPLINGS AND UNIT SQUARENESS

- **Use mechanical hoist (fork truck or other available means) to raise bed sections to approximate installed elevation.** Mate intermediate sections with either butt couplings or splice plates to join bed sections (see illustration).
- **One of the most critical elements of proper installation is unit squareness.** Check drive pulley, tail pulley, snub roller (if used in

drive assembly) and return roller assemblies to ensure these components are square with unit bed (see 'Belt Tracking' section later in handbook for detailed information).

- The unit must be installed at level elevation across the width to prevent erratic belt tracking.

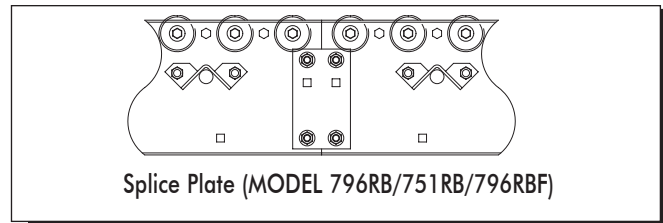
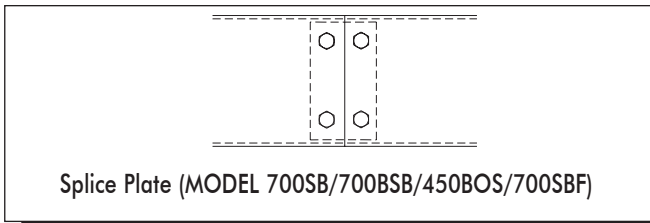

## SAFETY CONNECTOR BRACKETS (450BOS ONLY)

- Always use gravity connector bracket with pop out roller (see illustration) to permanently attach any gravity conveyor to 450 BOS conveyor.
- Never connect powered conveyors directly to gravity conveyors without using connector brackets with pop out roller.
- This simple connection eliminates hazardous pinch points that would otherwise exist by attaching a gravity conveyor directly to a powered belt unit.
- Connector Brackets are supplied as an optional component for the 450BOS.

- Connector brackets may not have been originally required for unit application, but they are readily available.

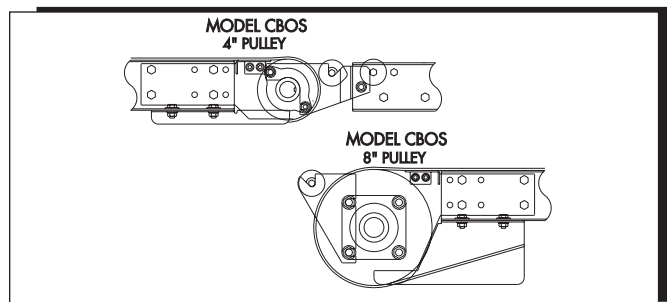

### WARNING

Never connect belt conveyors directly to gravity conveyors, machinery or fixtures without using connector brackets with pop out roller.

# INSTALLATION OF SUPPORTS IDENTIFYING/INSTALLING PERMANENT FLOOR SUPPORTS

Permanent supports may be installed on conveyors at various locations. However, it is most common to use single tier permanent floor supports at each end of a powered section (see illustration A) and where intermediate bed sections are adjoined (see illustration B). Notice intermediate supports have two lag bolts in a diagonal pattern while end (terminal) supports have four lag bolts, one in each of the four foot plate mounting holes.

When two (or more) powered conveyors are placed end-to-end, a single tier permanent support may be used at the end junction commonly supporting both units. Check load rating of support before using this method of installation.

Adjust elevation to top of conveyor by loosening bolts in support uprights, raising or lowering conveyor and fully tightening bolts at desired elevation. Tighten all bolts in supports **before** unit operation. Complete support installation by lagging support attachment plates to floor. Confirm that unit is level across width of conveyor before completing final support height adjustment.

Always anchor permanent supports to floor (or mounting sur-

face). Use 3/8" x 2-1/2" (or longer) wedge anchors for permanent installation in concrete flooring.

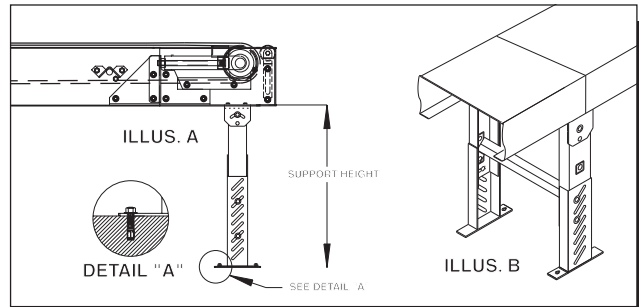

Supports are normally shipped at minimum support height.

*MINIMUM/MAXIMUM SUPPORT HEIGHT					
SM-1	.....	7-1/4"-10-1/4"	SM-7	.....	34-1/4"-46-1/4"
SM-2	.....	10-1/4"-13-1/4"	SM-8	.....	46-1/4"-58-1/4"
SM-3	.....	13-1/4"-16-1/4"	SM-9	.....	58-1/4"-70-1/4"
SM-4	.....	16-1/4"-22-1/4"	SM-10	.....	70-1/4"-82-1/4"
SM-5	.....	20-1/4"-26-1/4"	SM-11	.....	80-1/4"-92-1/4"
SM-6	.....	24-1/4"-36-1/4"	SM-12	.....	92-1/4"-104-1/4"

**WARNING**

Always anchor permanent supports to floor (or mounting surface).  
Use 3/8" x 2-1/2" (or longer) wedge anchors for permanent installation in concrete flooring.

## INSTALLING KNEE BRACES AND CASTERS

Knee braces add strength to permanent supports and stability to units in portable applications. Install knee brace (when supplied) after final permanent support installation and elevation adjustment. Its pivot bracket is bolted to underneath side of lower conveyor flange and slotted end is attached to outer side of support.

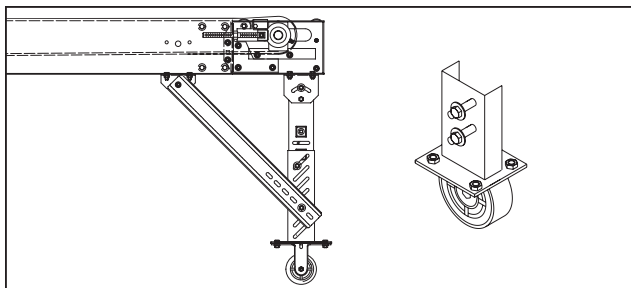

Knee braces are most commonly used at the terminal ends of long runs of conveyor lines and are recommended on inclined (or declined) floor-to-floor belt conveyors for added stability.

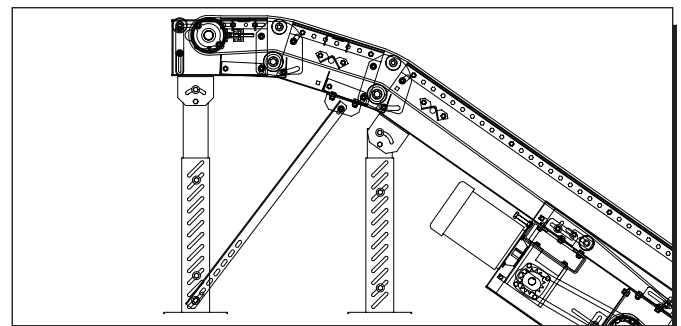

**Note:** Install knee brace (when supplied) after final permanent support installation and elevation adjustment

For a complete drawing and parts list log onto  
[http://www.roachconveyors.com/lit/Belt\\_Conveyors.pdf](http://www.roachconveyors.com/lit/Belt_Conveyors.pdf)

# POLYTIER SUPPORTS, CEILING HANGERS AND UNDERTRUSSING

## INSTALLATION OF POLYTIER SUPPORTS

Polytier supports provide convenient installation method for two or more tiers of conveyor. **To install, raise conveyor to desired elevation (approximate). Place 1" inside diameter cross pipe underneath lower conveyor flange. Attach cross pipe to upright legs. Use U-shaped retainer ("hat") bracket to connect cross pipe to lower conveyor flange. Do not tighten fully at this time.**

There are two styles of attachment brackets available for use with polytier supports. Minimum elevation style (see TYPE "0", illustration above) offers lowest unit elevation, 0" + frame depth utilizing L-shaped mounting bracket. Standard elevation style offers unit elevation of 3-1/2" + frame depth and includes bracket welded to cross pipe which is bolted to upright legs during installation.

When unit is at operating elevation and unit has been checked across width for level, tighten locking bolts in U-shaped bracket. Add knee braces for unit rigidity.

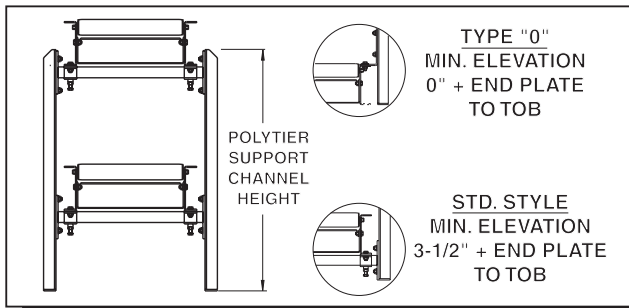

## INSTALLATION OF CEILING HANGERS

Ceiling hangers are frequently used in high-elevation applications for suspension from ceiling. The 5/8" diameter (#11 UNC) all threaded rod is supplied to allow infinite vertical adjustment along the length of the suspension rod (see illustration above).

Attach and firmly tighten U-shaped retainer ("hat") bracket to underneath side of lower conveyor flange with hardware provided to hold cross pipe (1" inside diameter) against underneath side of conveyor.

Do not tighten cross pipe locking bolts (these attach in the bottom of the U-shaped retainer bracket) until threaded suspension rods have been firmly secured to ceiling structure.

To adjust conveyor elevation, tighten or loosen lower nut and jam nut on threaded suspension rods to desired elevation. A lock washer must be used on suspension rods to maintain unit at desired elevation.

When unit is at operating elevation and unit has been leveled across bed width, tighten locking bolts in U-shaped bracket to secure position of cross pipe.

**It is the responsibility of the customer and installation personnel to supply and install net or mesh guarding on conveyors mounted overhead to prevent product and/or debris from falling to floor in areas where required.**

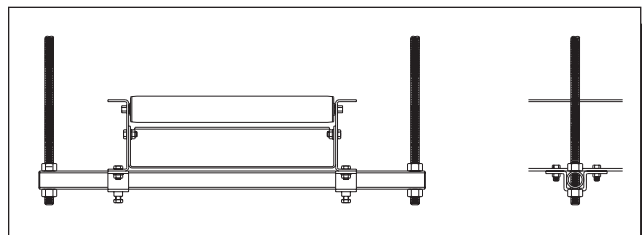

## INSTALLATION OF UNDERTRUSSING

When installing some conveyors, using a permanent support or ceiling hanger is simply not practical. In this situation, three bed sections (maximum) may be joined together utilizing truss assembly, mounted underneath conveyor (see illustration at right).

Adjoin beds on floor using both connector rod support assemblies and connector rods (5/8" diameter-11UNC threaded rod). The diagonal connector rod is used not only to support the intermediate bed section joint but it is instrumental for setting and maintaining proper tension across intermediate spanned beds.

Use mechanical hoist (fork truck or other means) to raise pre-assembled bed sections (with undertrussing) to desired elevation for final installation.

Use diagonal connector rods to level the undertrussed beds both along and across the conveyor. Remember that the tension must provide adequate for both dead load (conveyor weight) and product load during unit operation.

**It is the responsibility of the customer and installation personnel to supply and install net or mesh guarding on conveyors mounted overhead to prevent product and/or debris from falling to floor in areas where required.**

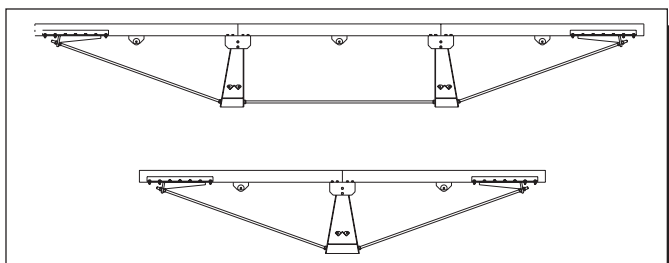

# INSTALLATION OF BELTING BELT CONNECTIONS

- Conveyor belting is cut to proper length, laced and assembled on conveyor at the factory. It is test run and inspected before it is shipped to its final destination.
- Before field installation of belting, it is critical to determine the correct side to be placed down. One of the most common problems associated with belt installation involves placing the incorrect side down.
- PVC belting is most commonly supplied as "COS" (cover one side). The opposite side, or side to be placed down, is a friction surface for decreased friction and improved conveyability. The friction side appears dull and grainy. ALWAYS place this side down against the conveyor bed. The cover side is darker and shiny.
- If unit is shipped "knocked down," belt must be re-threaded on unit during installation. (See page 13-14 for proper belt paths.)

- Join ends of belt as shown with lacing pin. Loosen threaded take-up rods (if necessary) at take-up pulley equal amount on both sides and re-adjust when belt is installed keeping pulley square with conveyor bed. A belt puller can also be used to join belting.

**Belt lacing must be kept in good condition for safe work environment.**

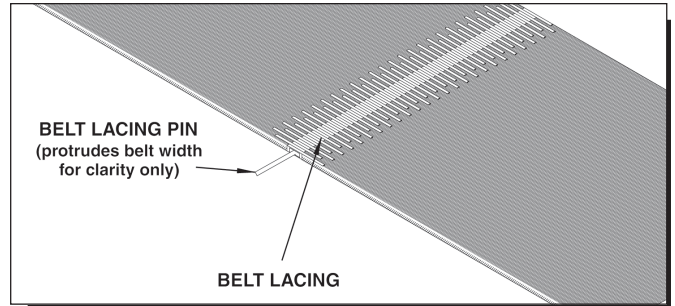

## MAINTAINING PROPER BELT TENSION

Maintaining proper belt tension is vital to unit operation. Enough tension should be maintained so that drive pulley does not slip under unit fully loaded conditions.

It is perfectly normal for a belt to stretch (in varying climatic conditions) under rated loading. Therefore, a short belt insert or "belt patch" (or patches) is provided for future removal when belting has stretched beyond means of conveyor take-up assembly. For yet additional belt take-up, the belt should be cut and re-laced to maintain proper belt tension.

To adjust conveyor take-up, adjust position of take-up rod (see illustration above) as required. Remember to equally adjust both sides to hold take-up pulley square (to maintain unit squareness for belt tracking). Operating unit with slipping belt will decrease life of both belting and pulley lagging.

**Also, do not operate unit with too much tension on belt. This will decrease belt life and may harm unit drive and take-up bearings. Over tensioning belt requires additional horsepower from unit drive and can cause belt mistracking.**

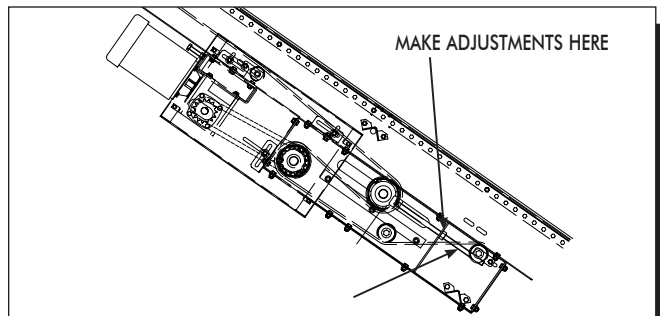
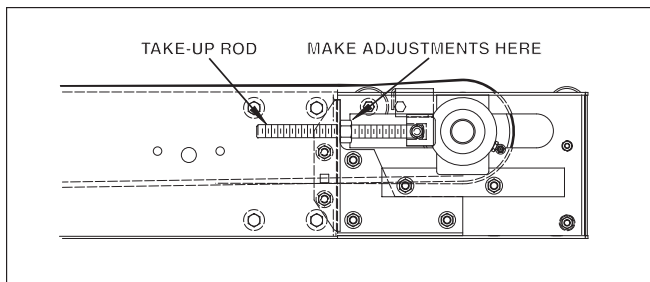

## NOSE-OVER AND SNUB ROLLER GUARD ADJUSTMENT

Nose-over assemblies may be supplied (optional) when slider/roller belt conveyors are inclined or declined to ease the transition from inclined to horizontal. A single nose-over assembly consists of one set of nose-over brackets with carrier roller, one snub roller with snub roller guard and attachment bracket. A double nose-over assembly includes one additional set of nose-over brackets and carrier roller.

Beds are cut and nose-over brackets and rollers are installed at the factory. Before unit is ready for operation, final adjustment of snub roller assembly is required to ensure safe unit operation. Snub roller guard (cover) should be set (see illustration above) with 1/4" belt clearance between bottom of belt and top of guard, both sides of guard, during final installation.

**caution: Before unit is ready for operation, snub roller guard (cover) must be adjusted to ensure safe unit operation.**

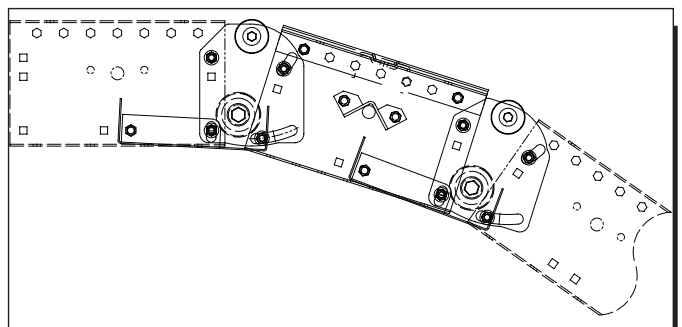



# START-UP PROCEDURES

## DRIVE CHAIN AND SPROCKET ALIGNMENT

Set up and maintenance of drive sprocket and drive chain alignment is critical. A periodic visual inspection is recommended to confirm alignment of drive components (which includes both drive sprockets and drive chain). Should set screws become loose, drive sprockets are subject to excessive wear and ultimately, to untimely replacement.

To check drive sprocket alignment, it is imperative that conveyor is shut "OFF" and power source is locked out before any adjustments are attempted. Remove chain guard cover and place straight-edge (see illustration) across face of both drive sprockets. If re-alignment is necessary, loosen set screws and adjust drive sprockets as required. Remember to securely tighten set screws when alignment is complete.

Before replacing chain guard cover, check drive chain tension as described in following section, "Drive Chain and Sprocket Tension."

Do not operate without guards in place.

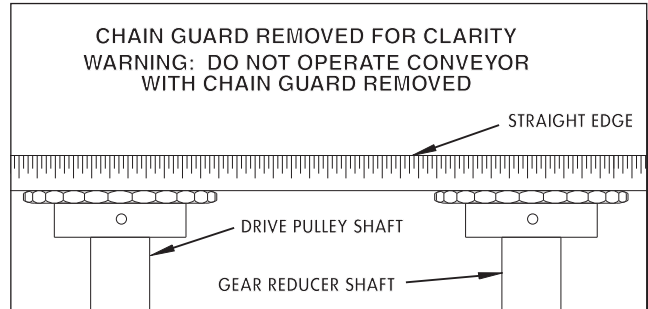

## DRIVE CHAIN AND SPROCKET TENSION

Maintaining proper chain tension is especially important. Again, a periodic visual inspection is recommended to ensure chain tension within a pre-determined operating range.

Remember, before any adjustments are attempted, conveyor must be shut "OFF" and power source locked out.

Before replacing chain guard cover, check to see if drive chain is operating within 1/2" range (see illustration). If unit is out of tolerance, adjustment is necessary.

To adjust drive chain tension, tensioner bolt located on reducer push plate should be tightened (rotate clockwise) if chain tension is loose. Tighten until proper operating range is achieved. If chain tension is too tight, loosen tensioner bolt (rotate counterclockwise) as

required. When adjustment is complete replace chain guard cover.

WARNING: Do not operate unit until chain guard cover is replaced. Serious operator or other personal injury could result if protective guarding is not replaced.

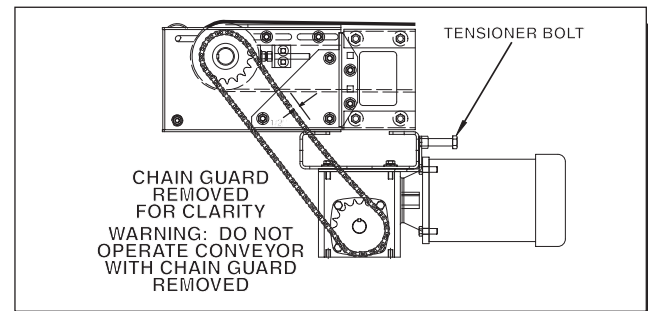

## GEAR REDUCER WITH POSIVENT

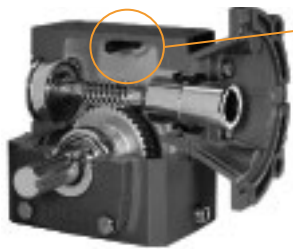

PosiVent Unique design incorporates a single seam construction. Factory filled with synthetic lubrication for universal mounting. Lubed for life, no oil changes are required.

No vent plug required.

## ELECTRICAL CONTROLS

Warn all personnel to keep clear of CONVEYOR during unit start-up



Electrical controls must be designed by a qualified electrical engineer to ensure that appropriate safety features (emergency stops, pull cords, switches, etc.) are installed on unit for safe operation.

## PREPARING FOR INITIAL START-UP

Provisions must be in order to instruct all personnel coming in contact with conveyor on the location of emergency stops, pull cords, etc.

A routine maintenance program should be implemented before unit is placed into operation so that fundamental unit components are attended to. This maintenance program should include an inspection to ensure that any dangerous or hazardous operating conditions are

noted and IMMEDIATELY corrected, as well as including electrical and mechanical unit inspections and corrections.

Finally, when conveyor is initially started, an immediate visual inspection should include motor, gear reducer, belt tracking (discussed in following section under "Belt Tracking") and related adjustments noted in handbook for unit/component corrections.

# BELT TRACKING GENERAL INFORMATION

Upon initial use the belting will stretch after a few days of operation. Remember that maintaining proper belt tension is a crucial element in belt tracking. Therefore, this stretching of a belt when placed into operation may affect its ability to track. Adjustment of the take-up pulley will likely adequately compensate for initial stretch. However, depending on the overall unit length, removal of a belt patch may be necessary to correct.

**ONLY trained personnel should make belt tracking adjustments.**

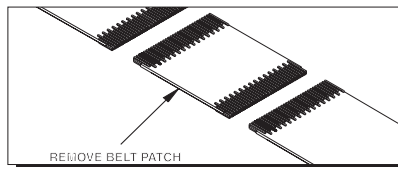

Belt must be tracked in both unloaded and loaded situations. The return direction of the belt must clear supports, ceiling hangers, floor

openings, etc. Dragging on such components will contribute to belt tracking problems and is certain to damage belting at extended intervals.

In a reversible application, a belt that runs off to one side in one direction will likely run off to the other side when operated in the opposite direction. Do not allow belt to rub against side of conveyor frame, which will surely damage belt.

## SKEWING RETURN ROLLERS

One of the most common and productive means to track conveyor belting is to skew rollers. Excess skewing of rollers, which may cause belt to bow and may force belt to rub on side frame causing belt damage, usually will not completely solve belt tracking problems

**tracking adjustments. Shut unit "OFF" and lock out power source before attempting**

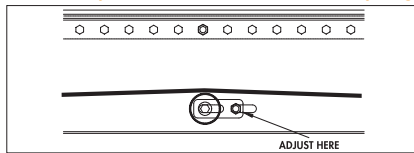

To adjust return rollers, simply loosen attach-

ment bolt that secures bracket to the side of the conveyor (see illustration above). Move bracket to skew return roller assemblies (as noted in Advanced Tracking Adjustments later in manual). Remember to make adjustments in SMALL increments.

When adjustment is complete, tighten bolt firmly securing return roller bracket to the side

**ONLY trained personnel should make belt**

## ERRATIC TRACKING AT START-UP

Improper tracking of conveyor belting should be considered a "systems" problem rather than solely a deficiency in the belt. To explain, a belt is tracked with adjustments made in the system or entire conveyor rather than just the belting.

**Upon start-up, if belt tracks to one side of unit, turn unit "OFF", lock out power source and confirm that conveyor is square. All prime tracking components must be square**

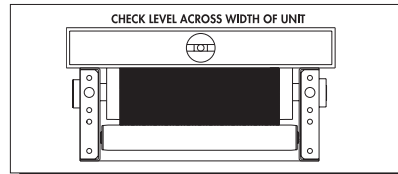

**with bed including drive pulley, tail pulley, snub roller and return rollers.** Both sides of take-up should be adjusted exactly the same amount. The conveyor should be level across

the width of the unit. Confirm that the belt has been properly threaded (see "Belt Path" section) and that belt lacing is square with the belt edges. Make adjustments as necessary; however, all adjustments should be made in small increments.

Start conveyor again and operate for at least ten minutes once initial phase of adjustments are complete. If belt continues to track erratically, turn unit "OFF" before belt is allowed to run so far off center that it rubs side of conveyor.

## ADVANCED TRACKING ADJUSTMENTS

When adjustments noted in section above have been completed and belt continues to track erratically, a second series of tracking adjustments are necessary.

First, determine the infeed and discharge ends of the conveyor. The following adjustments will be made with the infeed end as the reference point.

If belt tracks toward side "R" (see illustration above), skew return rollers in direction "B" to shift belting toward side "L". If belt tracks

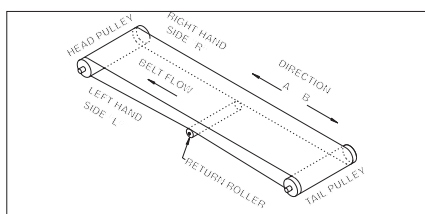

toward side "L", skew return rollers in direction "A" to shift belting toward side "R".

Skewing head pulley (pulley at unit discharge) in direction "A" moves belt toward side "L". Skewing head pulley in direction

"B" moves belt toward side "R".

As a rule of thumb, do not use drive and take-up pulley for belt tracking since this will overly increase belt tension. When adjusting take-up pulley, adjust both sides an equal amount.

As a last resort, shift the tail pulley in direction "B" to move belting toward side "L"; shift head pulley in direction "A" to move belting toward side "L".

# MAINTENANCE SAFETY PRECAUTIONS BEFORE PERFORMING MAINTENANCE

- One of the most important guidelines for maximizing conveyor operation and personnel safety is to implement a regular maintenance schedule and train personnel on the appropriate needs of the specific unit.
- **Only trained personnel shall perform maintenance functions. Before maintenance operations are performed, conveyor must be shut "OFF" and disconnects locked in the "OFF" position to prevent unit from unauthorized start-up during maintenance. All**

**personnel should be informed of the safety procedures associated with unit maintenance and performance.**

- Do not perform any work on conveyors or conveyor system while in operation unless it is impossible to otherwise conduct adjustment, lubrication or other maintenance function.
- Only experienced, trained personnel possessing advanced hazards-training should attempt such critical operations.

## MAINTENANCE AND FOLLOW-UP DETAILS

- While performing maintenance do not wear loose clothing. Immediately report any hazardous conditions-sharp edges, pinch (or nip) points or other conditions that may result when several manufacturers supply machinery which may create operating hazards.
- When using mechanical aids such as hoists, cables, or cranes exercise extreme caution to prevent damage to conveyors or other integrated machinery which may create a working hazard when maintenance is completed and units are in operation.
- Clean up any spilled lubricants or other materials used in the maintenance process or those which may be deposited during unit operation. Eliminating poor housekeeping practices increases unit efficiency while creating safer personnel working conditions.

- After maintenance, conduct visual inspection to ensure that all safety devices and guards have been replaced. Confirm that all units are clear of tools, debris or other items. Before starting conveyor, check condition of conveyor warning labels (see "WARNING LABELS" at front of handbook). If labels have been destroyed or are not clearly legible, call 870.483.7631 to receive replacement labels. Placement of warning labels is critical to avoid unauthorized unit operation which may result in hazardous working conditions for all related personnel coming in contact with conveyor.
- Warn personnel that conveyor is being prepared for start-up and to stay clear of unit. Do not start conveyor until all personnel are clear. When maintenance is completed, only authorized personnel shall be permitted to start conveyor following maintenance or other emergency shut-off.

## MAINTENANCE PERIODIC MAINTENANCE SCHEDULE AND LUBRICATION

WEEKLY RECOMMENDED MAINTENANCE SCHEDULE*	
COMPONENT	DETAIL OF MAINTENANCE
BELTING	Inspect belt tracking
PILLOW BLOCK / FLANGE BEARINGS	Lubricate in dirty, dusty, or moist/wet conditions
UNIT SAFETY CHECK	Confirm placement of all guards, pop-out rollers, warning labels & check for loose bolts, nip points & other hazards

MONTHLY RECOMMENDED MAINTENANCE SCHEDULE*	
COMPONENT	DETAIL OF MAINTENANCE
GEAR REDUCER	Check for leaks
BELTING	Inspect belt tracking
PILLOW BLOCK / FLANGE BEARINGS	Lubricate in dirty, dusty, or moist/wet conditions
DRIVE CHAIN	Check for proper operating tension & overall wear & lubricate
DRIVE SPROCKETS	Check for overall wear & re-tighten set screws

PERIODIC RECOMMENDED MAINTENANCE SCHEDULE*	
COMPONENT	DETAIL OF MAINTENANCE
GEAR REDUCER	Check for leaks
DRIVE CHAIN	Clean (brush in solvent) & re-lubricate by applying lubricant to inside of chain with brush or spout can at 2000 hour intervals
MOTOR	Check & clear motor ventilation openings at 500 hour intervals. Check miscellaneous operating conditions (normal heat & noise)

MISC. LUBRICANTS**	
General Purpose Grease (For -30°F to 300°F operation)*	Shell Dolium R (Shell Oil Co.) (or suitable equivalent)
For Extreme Temperature Operation (-90°F to 350°F operation)*	Mobiltemp SHC-32 (Mobil Oil Corp.) (or suitable equivalent)
Washdown Application* (-30°F to 225°F operation) (May require special consideration consult factory)	Shell Alvania No. 3 (Shell Oil Co.) (or suitable equivalent)
General Purpose Oil	SAE 10; SAE 20 OR SAE 30

\*All charts are for guidelines in normal operating or 'as noted' conditions. Severe applications warrant additional maintenance.

\*\*NOTE: Temperatures listed indicate the nominal operational temperature for the specific lubricant listed. This does not imply that the bearing housing, seals or any other conveyor unit component is rated to operate in this specific temperature range or environment. 250°F is the maximum operating temperature for standard bearing lubricants and bearing components. Although various lubricants may enhance bearing operation, special-order bearings may be required to achieve optimal bearing performance. For additional information, consult factory.

# BELT PATH ILLUSTRATION FOR UNITS WITH END DRIVE

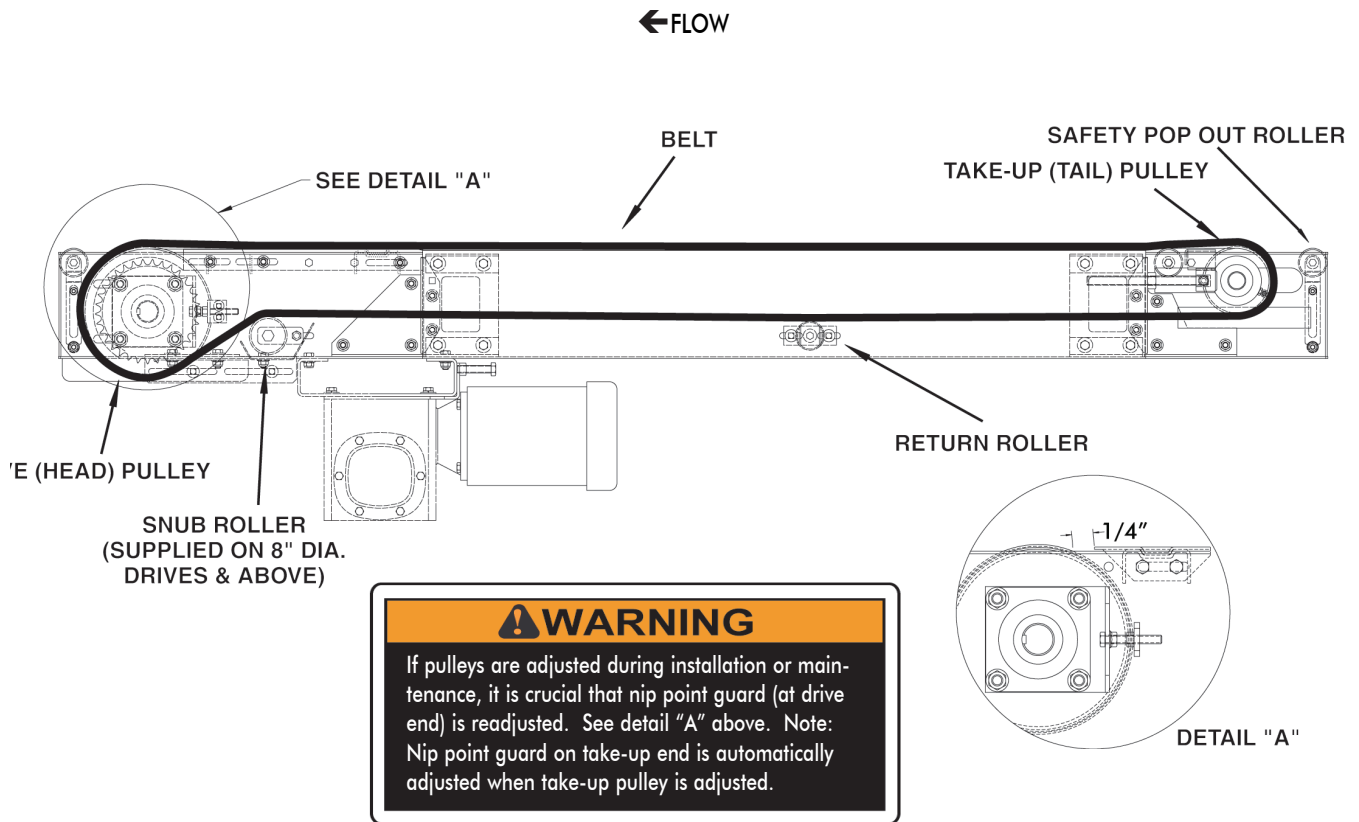

# ILLUSTRATION FOR UNITS WITH CENTER DRIVE

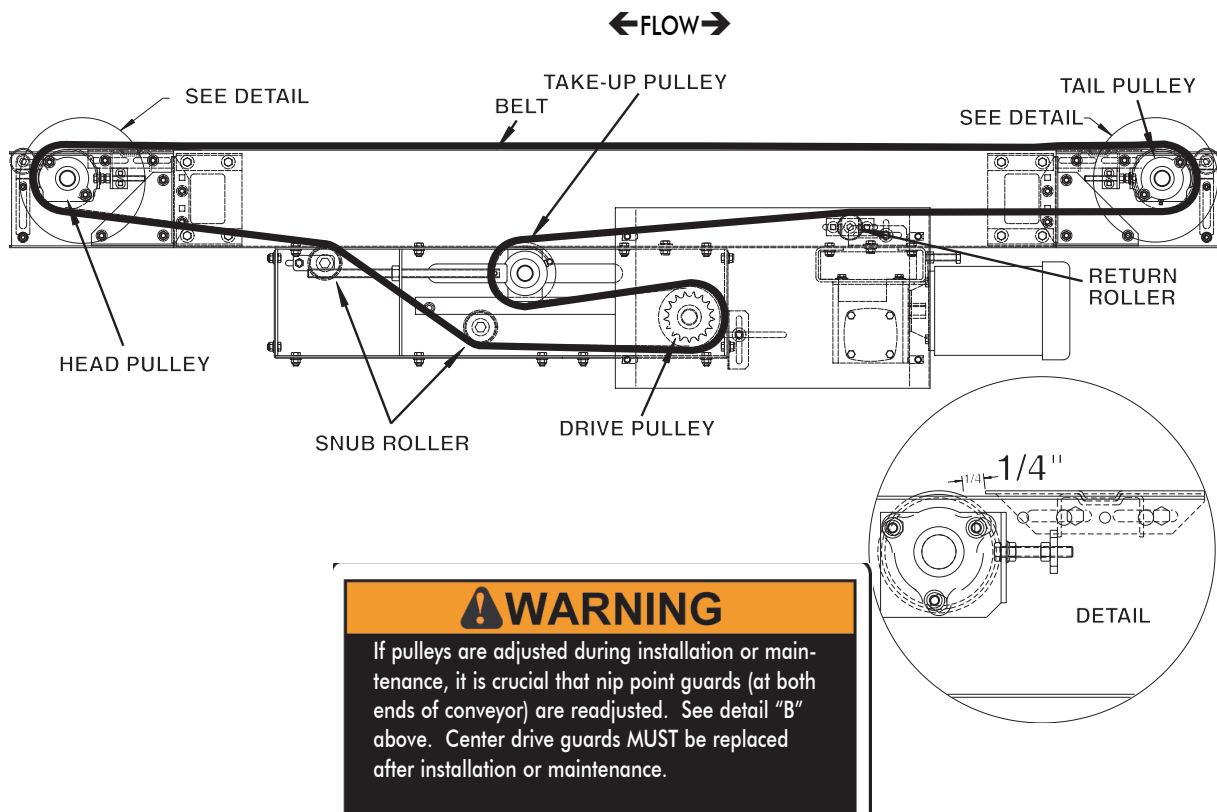

# BELT PATH ILLUSTRATION FOR INCLINE UNIT

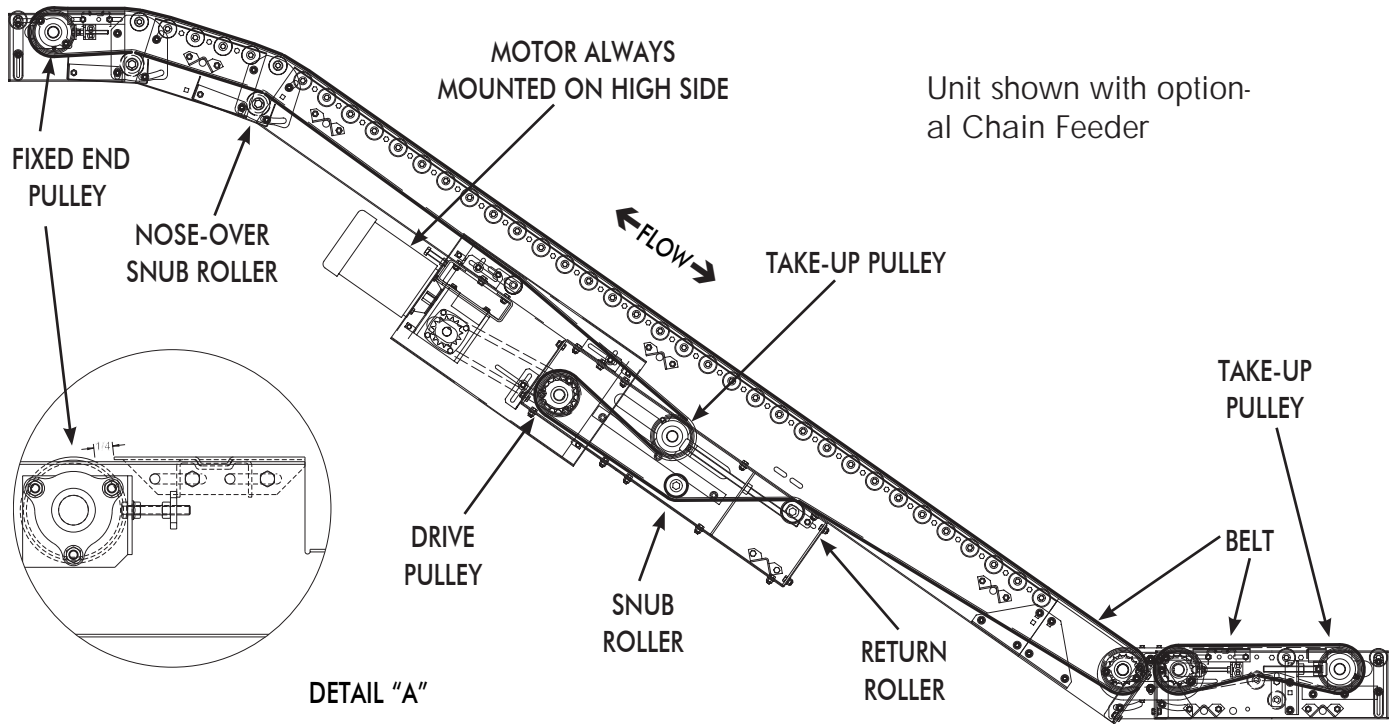

**CAUTION:** If pulleys are adjusted during installation or maintenance, it is crucial that nip point guards (at both ends of conveyor) are readjusted. See DETAIL "A" at left. Center drive guards **MUST** be replaced after installation or maintenance. If optional feeder is used, nip point guards in end assemblies (including drive or fixed end pulley) must be adjusted when feeder pulleys are adjusted.

## CHAIN DRIVEN AND INTEGRAL FEEDERS

Two types of feeders (both optional) are commonly supplied on floor-to-floor belt conveyors. Horizontal chain driven feeders (see above illustration) are powered from the inclined (or declined) conveyor section via slave drive connection. This feeder requires one support at each end of the feeder and an additional support at each intermediate feeder bed section when installing.

Integral feeders (see illustration at right) use a 3-pulley device to transfer the belt from its inclined section to the horizontal feeder for loading or unloading from the floor-to-floor conveyor. Here, the same type of belting,

generally supplied as 2-ply ruff-top, is used on both feeder and inclined section due to the continuous travel of the belt. Note that the support at the terminal feeder end must be 7" taller to top of support than the support assembly placed under the 3-pulley device, which commonly supports both intermediate feeder and inclined section.

**NOTE:** Optional integral feeders and chain driven feeders are often used to transfer product from horizontal position to inclined or declined conveyor section. Always use feeder when transferring to or from gravity conveyors.

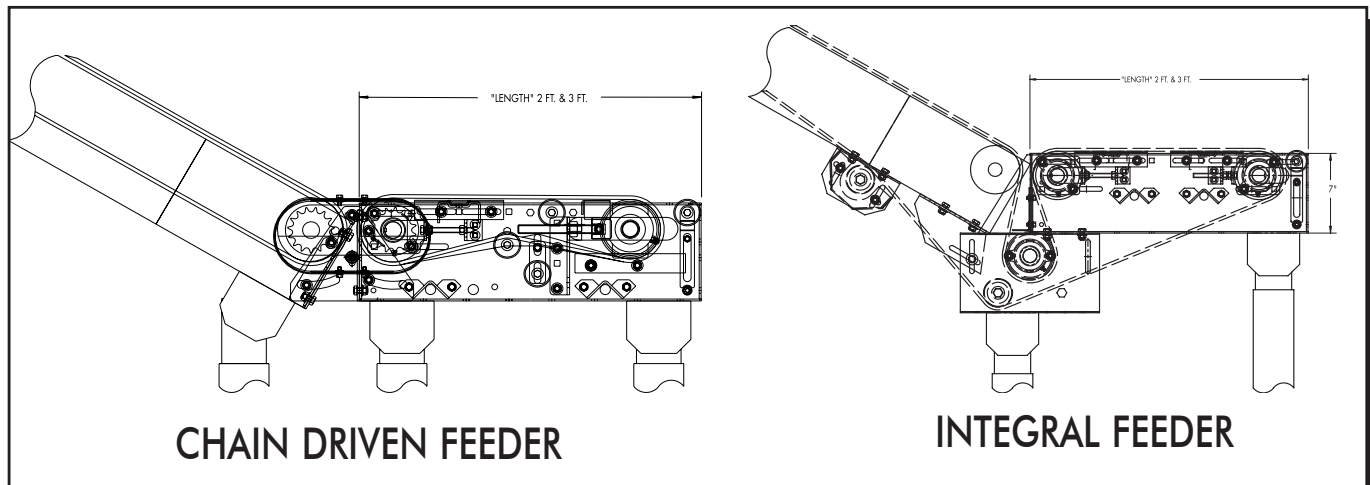



# TROUBLE SHOOTING AND REPLACEMENT PARTS

## TROUBLE SHOOTING / SERIAL PLATE

TROUBLE SHOOTING		
TROUBLE	PROBABLE CAUSE	REMEDY
Motor & gear reducer running excessively hot, or hard to start	A. Drag on conveyor B. Lack of lubricant C. Frozen sprocket D. Frozen roller E. Overload F. Electrical	A. Inspect entire conveyor for obstruction causing drag on chain. B. Check for leaks. C. Check and inspect all sprockets and bearings. Replace sprockets failing to rotate or that are difficult to rotate. D. Check all rollers for rotation. E. Reduce cause and/or increase motor horsepower. F. Check wiring and circuits, take ampere reading, replace motor if necessary.
Motor & gear reducer makes excessive noise	A. Lack of lubrication B. Damaged Gears C. Faulty Bearing	A. Check for leaks. B. Replace unit. C. Replace bearing.
Drive chain, conveying chain or sprockets experience excessive wear	A. Excessive chain tension B. Sprockets misaligned C. Chain not lubricated D. Damaged sprocket or chain E. Misalignment of chain guard F. Dirty chain	A. Reduce chain tension. B. Realign with straight edge across sprocket faces. C. Lubricated chain with approved lubricant, wipe away excess lubricant. D. Replace Damaged Component. E. Adjust chain guard assembly as necessary. F. Clean thoroughly and lubricate with approved lubricant.
Drive chain, conveying chain or sprockets make excessive noise	A. Insufficient chain tension B. Chain not adequately lubricated C. Sprockets misaligned	A. Adjust chain tension. B. Lubricate chain with approved lubricant, wipe away excess lubricant. C. Realign sprockets with straight edge across sprocket faces.
Pulsating chain	A. Insufficient chain tension B. Misalignment of chain guard C. Overload	A. Adjust chain tension. B. Adjust chain guard assembly as necessary. C. Inspect for obstruction to or drag on conveyor.
Broken chain	A. Frozen bearing or sprocket shaft B. Worn or damaged chain C. Obstructed or jam	A. Inspect for damaged bearings, replace if necessary. Replace links as required. B. Replace chain as required. C. Remove obstruction to clear jam.
Sprocket loose on shaft	A. Loose set screws B. Worn or damaged key	A. Realign sprockets with straight edge and tighten set screws. B. Replace with new key.
Excessive slack in chain	A. Normal wear	A. Expect rapid chain growth in first two weeks of operation. B. Adjust chain tension as specified in the manual.

### ORDERING REPLACEMENT PARTS

To order any replacement parts or when calling for assistance with any powered conveyor, **ALWAYS** provide the unit serial number. Shown at actual size, this aluminum plate is placed on the conveyor frame near the location of the drive assembly.

To order replacement parts or add-on components, contact the Roach distributor who originally furnished the unit if possible. If this is not possible, contact the National Sales Office at 870-483-7631 for the name of the authorized Roach distributor in your area.

Have unit model number and serial number **BEFORE** calling. Refer to

unit drawings on the Roach Conveyors website (<http://roachconveyors.com/belt-conveyor.htm>) for part numbers if ordering replacement parts.

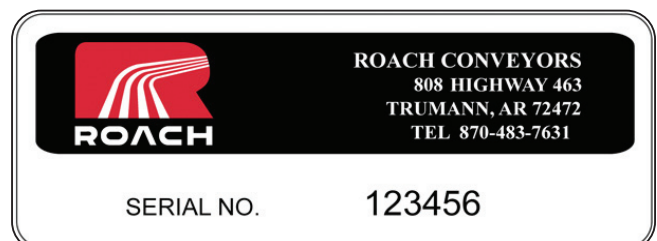

# MODEL 725TB PARTS LIST

ITEM #	DESCRIPTION
1	725TB End Bed Section
2	Guard Rail Fastener Strap
3	Return Roller Bracket
4	Splice Plate
5	Bed Pan Brace Channel
6	196S Roller Assembly
7	End Trough Bed
8	Intermediate Trough Bed
9	Box Type Bed
10	725TB Full Length Bed Assembly
11	End Trough Bed
12	725TB Full Length Center Drive Bed Assembly
13	725TB Intermediate Bed Assembly
14	Intermediate Bed
15	End Take-up Assembly
16	5/8" Diameter Take-up Rod
17	1-3/16" Milled Take-up Bearing RH
18	1-3/16" Milled Take-up Bearing LH
19	5/16" - 18 x 2" Hex Flange HCS
20	5/16" - 18 Nylon Insert Locknut
21	1/4" Flat Washers
22	5/8" - 11 Hex Nut
23	Safety Pop-out Roller Assembly
24	Take-up Bearing Guide
25	Bolt-in Butt Coupling
26	Take-up Bed Joint Mounting Angle
27	Idler Pulley Assembly
28	Take-up Plate
29	Bearing Guide Spacer
30	Top Take-up Bearing Guide
31	5/16" Flat Washer
32	Fixed End Assembly
33	Safety Pop-out Roller Assembly
34	Bolt-in Butt Coupling
35	Bearing Take-up Mounting Angle
36	Bearing Push Plate
37	Bed Joint Mounting Angle
38	Idler Pulley Assembly
39	Fixed End & Drive Plate Assembly
40	2-Hole Flange Bearing w/ 1-3/16" Bore
41	End Drive Assembly
42	Safety Pop-out Roller Assembly

ITEM #	DESCRIPTION
43	Bolt-in Butt Coupling
44	Bearing Take-up Mounting Angle
45	Bearing Push Plate
46	Bed Joint Mounting Angle
47	Drive Pulley Assembly
48	Fixed End & Drive Plate Assembly
49	4 Hole Flanged Bearing w/ 1-7/16" Bore
50	2.5 Roller Keeper
51	251S Roller Assembly
52	Belt Guards
53	Snub Roller Belt Guard
54	Center Drive Assembly
55	2.5 Roller Keeper
56	Center Drive Take-up Bearing Guide
57	(Milled) Take-up Bearing Assembly
58	251S Roller Assembly
59	Center Drive Plate Weld Assembly
60	Drive Pulley
61	Idler Pulley Assembly
62	Center Drive Belt Guard
63	Center Drive Belt Guard
64	Frame Crossbrace
65	4 Hole Flange Bearing w/ 1-15/16" Bore
66	3 Hole Flange Bearing w/ 1-3/16" Bore
67	Belting Assembly
68	Sidemount Drive Kit
69	Motorbase Stiffener Assembly (1HP+)
70	Reducer Push Plate Assembly
71	Sidemount Motorbase Plate
72	Sidemount Chain Guard Assembly
73	End Drive Kit
74	Motorbase Stiffener Assembly
75	Chain Guard Mounting Angle
76	Reducer Push Plate Assembly
77	Underneath Motorbase Plate
78	Chain Guard Assembly
79	Center Drive Kit
80	Motorbase Stiffener Assembly (1HP+)
81	Reducer Push Plate Assembly
82	Underneath Motorbase Plate
83	Center Drive Chain Guard Assembly

Specify **Unit Serial Number** when ordering replacement parts to ensure proper allocation of components (See Ordering Replacement Parts on page 15).

Recommended Spare Parts are shown in red. Charted are item numbers and part descriptions. When ordering use example below.

Example: Need a replacement End Take-up Assembly for a 725TB.  
Part No: SN 123456 - 15 - End Take-up Assembly





# MODEL 725TB END DRIVE, END SIDE MOUNT DRIVE & CENTER DRIVE DRAWINGS

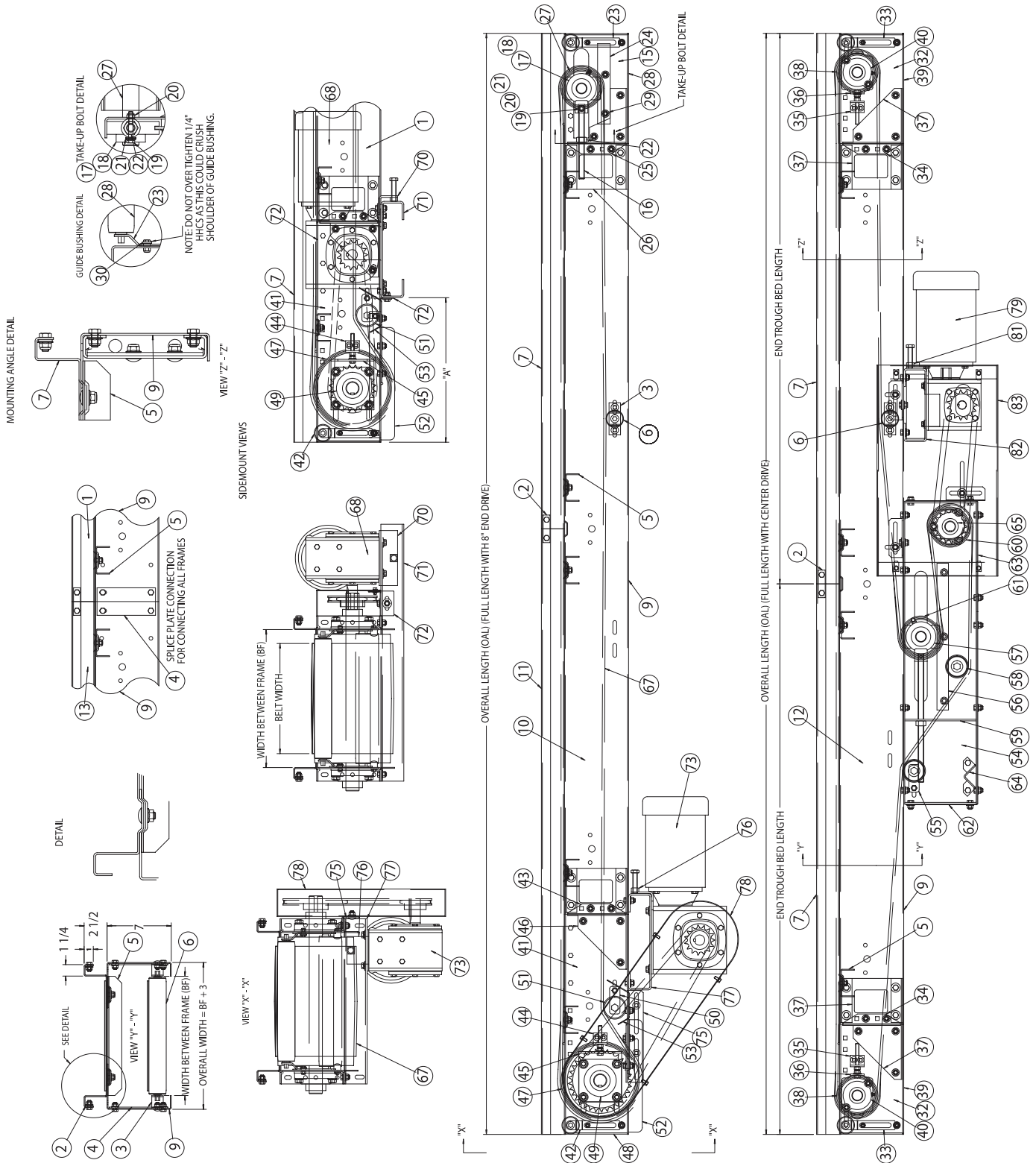

# MODEL 700SB PARTS LIST

ITEM #	DESCRIPTION
1	700SB Intermediate Bed Assembly
2	1.9 Roller Keeper
3	Splice Plate
4	Bed Pan Brace Channel
5	196S Roller Assembly
6	Slider Bed Pan
7	Medium Duty Side Channel
8	Frame Crossbrace
9	End Take-up Assembly
10	5/8" Diameter Take-up Rod
11	Safety Pop-out Roller Assembly
12	Take-up Bearing Guide
13	Bolt-in Butt Coupling
14	Take-up Bed Joint Mounting Angle
15	Take-up Filler Pan
16	Idler Pulley Assembly
17	196S Roller Assembly
18	Take-up Plate
19	Bearing Guide Spacer
20	Top Take-up Bearing Guide
21	Fixed End Assembly
22	Safety Pop-out Roller Assembly
23	Bearing Take-up Mounting Angle
24	Bed Pan Brace Channel
25	Bearing Push Plate
26	Bed Joint Mounting Angle
27	Idler Pulley Assembly
28	Fixed End & Drive Plate Assembly
29	Filler Pan
30	4 Hole Flanged Bearing w/ 1-7/16" Bore
31	End Drive Assembly
32	Safety Pop-out Roller Assembly
33	Bearing Take-up Mounting Angle
34	Bed Pan Brace Channel
35	Bearing Push Plate
36	Bed Joint Mounting Angle
37	Drive Pulley Assembly

ITEM #	DESCRIPTION
38	Fixed End & Drive Plate Assembly
39	Filler Pan
40	4 Hole Flange Bearing w/1-7/16" Bore
41	2.5 Roller Keeper
42	Belt Guard
43	Snub Roller Belt Guard
44	251S Roller Assembly
45	Center Drive Assembly
46	2.5 Roller Keeper
47	Center Drive Take-up Bearing Guide
48	(Milled) Take-up Bearing Assembly LH/RH
49	251S Roller Assembly
50	Center Drive Plate Weld Assembly
51	Drive Pulley Assembly
52	Idler Pulley Assembly
53	Center Drive Belt Guard
54	Center Drive Belt Guard
55	Frame Crossbrace
56	4 Hole Flanged Bearing w/1-7/16" Bore
57	3 Hole Flanged Bearing w/1-3/16" Bore
58	Belting Assembly
59	Sidemount Drive Kit
60	Motorbase Stiffener Assembly (1HP+)
61	Reducer Push Plate Assembly
62	Sidemount Motorbase Plate
63	Sidemount Chain Guard Assembly
64	End Drive Kit
65	Motorbase Stiffener Assembly (1HP+)
66	Chain Guard Angle Mount
67	Reducer Push Plate Assembly
68	Underneath Motorbase Plate
69	Chain Guard Assembly
70	Center Drive Kit
71	Motorbase Stiffener Assembly (1HP+)
72	Reducer Push Plate Assembly
73	Underneath Motorbase Plate
74	Center Drive Chain Guard Assembly

Specify **Unit Serial Number** when ordering replacement parts to ensure proper allocation of components (See Ordering Replacement Parts on page 15). **Recommended Spare Parts are shown in red. Charted are item numbers and part descriptions.** When ordering use example below.

Example: Need a replacement Drive Pulley Assembly for a 700SB.  
Part No: SN 123456 - 51 - Drive Puller Assembly

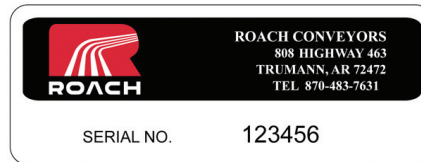



# MODEL 700BSB PARTS LIST

ITEM #	DESCRIPTION
1	700BSB Intermediate Bed Assembly
2	Return Roller Bracket
3	Splice Plate
4	196S Roller Assembly
5	700 Box Type Bed Section
6	Bed Pan Brace Channel
7	700 Box Side Channel
8	Bed Pan
9	Frame Crossbrace
10	End Take-up Assembly
11	5/8" Diameter Take-up Rod
12	Safety Pop-out Roller Assembly
13	Take-up Bearing Guide
14	Bolt-in Butt Coupling
15	Take-up Bed Joint Mounting Angle
16	Take-up Filler Pan
17	Idler Pulley Assembly
18	196S Roller Assembly
19	Take-up Plate
20	Bearing Guide Spacer
21	-
22	Fixed End Assembly
23	Safety Pop-out Roller
24	Bolt-in Butt Coupling
25	Bearing Take-up Mounting Angle
26	Bed Pan Brace
27	Bearing Push Plate
28	Bed Joint Mounting Angle
29	Idler Pulley Assembly
30	Fixed End & Drive Plate Assembly
31	Filler Pan
32	4 Hole Flanged Bearing w/ 1-7/16" Bore
33	End Drive Assembly
34	Safety Pop-out Roller Assembly
35	Bolt-in Butt Coupling
36	Bearing Take-up Mounting Angle
37	Bed Pan Brace
38	Bearing Push Plate
39	Bed Joint Mounting Angle

ITEM #	DESCRIPTION
40	Drive Pulley Assembly
41	Fixed End & Drive Plate Assembly
42	Filler Pan
43	4 Hole Flanged Bearing w/ 1-7/16" Bore
44	2.5 Roller Keeper
45	Belt Guard
46	Snub Roller Belt Guard
47	251S Roller Assembly
48	Center Drive Assembly
49	2.5 Roller Keeper
50	Center Drive Take-up Bearing Guide
51	(Milled) Take-up Bearing Assembly LH/RH
52	251S Roller Assembly
53	Center Drive Plate Weld Assembly
54	Drive Pulley Assembly
55	Idler Pulley Assembly
56	Center Drive Belt Guard
57	Center Drive Belt Guard
58	Frame Crossbrace
59	4 Hole Flanged Bearing w/ 1-7/16" Bore
60	3 Hole Flanged Bearing w/ 1-3/16" Bore
61	Belting Assembly
62	Sidemount Drive Kit
63	Motorbase Stiffener Assembly (1HP+)
64	Reducer Push Plate Assembly
65	Sidemount Motorbase Plate
66	Sidemount Chain Guard Assembly
67	End Drive Kit
68	Motorbase Stiffener Assembly (1HP+)
69	Chain Guard Angle Mount
70	Reducer Push Plate Assembly
71	Underneath Motorbase Plate
72	Chain Guard Assembly
73	Center Drive Kit
74	Motorbase Stiffener Assembly (1HP+)
75	Reducer Push Plate Assembly
76	Underneath Motorbase Plate
77	Center Drive Chain Guard Assembly

Specify **Unit Serial Number** when ordering replacement parts to ensure proper allocation of components (See Ordering Replacement Parts on page 15). Recommended Spare Parts are shown in red. Charted are item numbers and part descriptions. When ordering use example below.

Example: Need a replacement Center Drive Chain Guard Assembly for a 700BSB.

Part No: SN 123456 - 77 - C/D Chain Guard Assembly



# MODEL 700BSB END DRIVE, END SIDE MOUNT DRIVE & CENTER DRIVE DRAWINGS

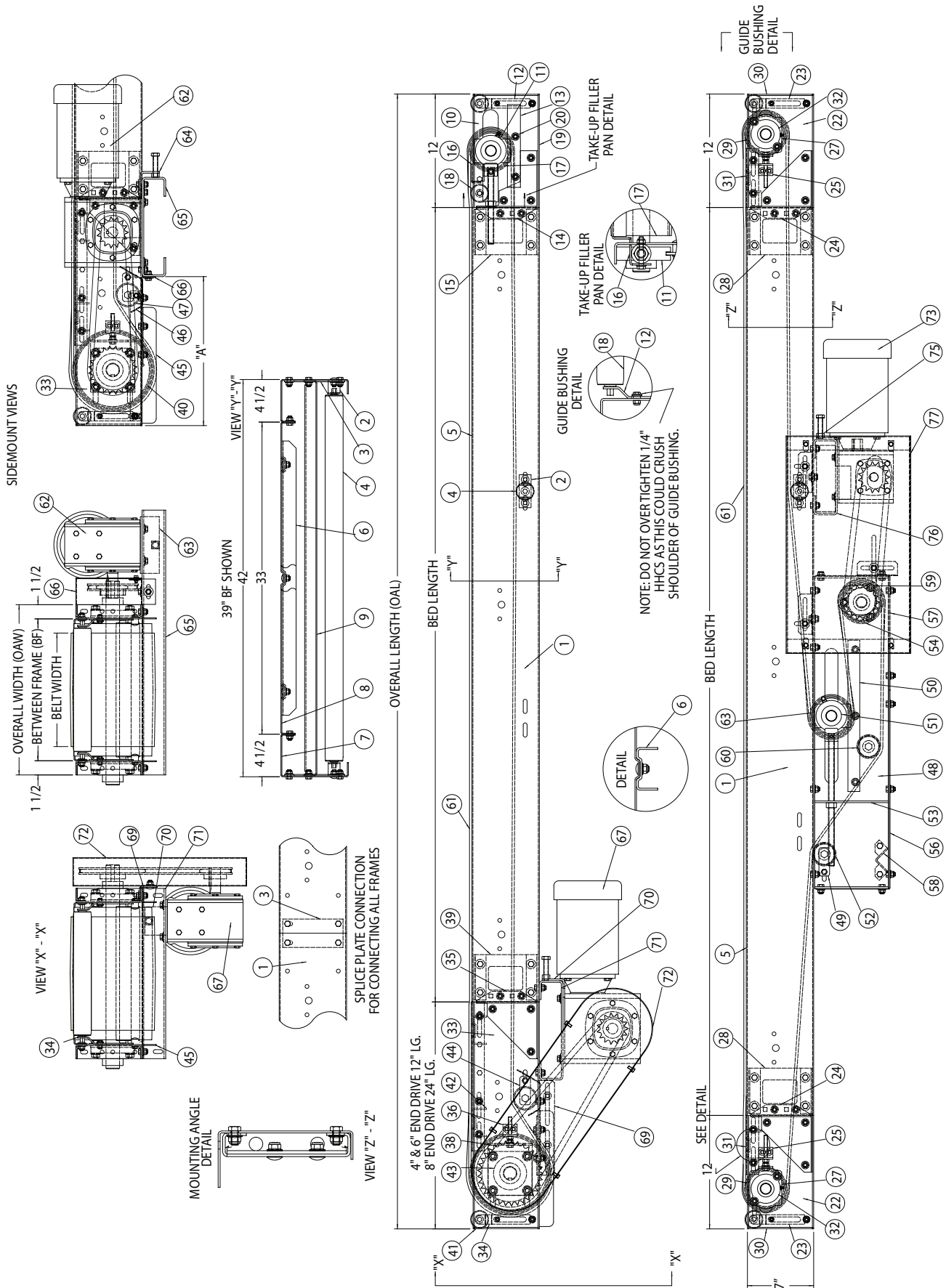

# MODEL 450BOS PARTS LIST

ITEM #	DESCRIPTION
1	End Bed Assembly
2	1.9 Return Roller Bracket
3	196S Roller Assembly
4	Splice Plate
5	450 Box Type End Bed
6	Bed Pan Brace Channel
7	Full Length Bed Assembly
8	Intermediate Bed Assembly
9	196 Snub Roller Guard (4" Fixed, End Drive, & Take-up)
10	196 Snub Roller Guard (4" Sidemount Drive)
11	4" End Take-up Assembly
12	4" Round Style Take-up Plate
13	4" Round Style Take-up Plate
14	4" Idler Pulley Assembly
15	Filler Pan (Universal)
16	Bolt-on Take-up Plate
17	2 Hole Flanged Bearing
18	Take-up Bolt 1/2" - 13 x 6" LG.
19	4" Fixed End Assembly
20	4" Round Style Fixed End Plate
21	4" End Drive Assembly
22	4" Drive Pulley Assembly
23	8" End Drive Assembly
24	8" Fixed End & Drive Plate
25	2.5 Return Roller Bracket
26	251S Roller Assembly
27	Snub Roller Guard for 8" Drives
28	8" Drive Pulley Assembly
29	Filler Pan (8" End Drives)
30	4 Hole Flanged Bearing
31	4" Center Drive Assembly
32	2.5 Roller Keeper
33	Center Drive Bearing Guide
34	Take-up Bearing Assembly (LH)

ITEM #	DESCRIPTION
35	Take-up Bearing Assembly (RH)
36	251S Roller Assembly
37	4" Center Drive Plate (LH)
38	4" Center Drive Plate (RH)
39	4" Drive Pulley Assembly
40	4" Idler Pulley Assembly
41	4" Center Drive Belt Guard
42	4" Center Drive Belt Guard
43	Frame Crossbrace
44	3 Hole Flanged Bearing
45	Bearing Guide Spacer
46	8" Center Drive Plate (LH)
47	8" Center Drive Plate (RH)
48	8" Drive Pulley Assembly
49	8" Center Drive Belt Guard
50	8" Center Drive Belt Guard
51	4 Hole Flanged Bearing
52	Belting Assembly
53	Gear Reducer
54	Motor
55	Sidemount Drive Assembly
56	Motorbase Stiffener Assembly (1HP+)
57	Motorbase Spacer 8" End Drive
58	Reducer Push Plate Assembly
59	Side Mount Motorbase Plate
60	Side Mount Chain Guard Assembly
61	Underneath Mount Drive Assembly
62	Underneath Mount Motorbase Plate
63	Reducer Push Plate Assembly
64	Guard Mounting Bracket
65	Underneath Mount Chain Guard
66	Drive Assembly for Center Drive
67	Center Drive Chain Guard Mounting Bracket
68	Center Drive Chain Guard Assembly

Specify **Unit Serial Number** when ordering replacement parts to ensure proper allocation of components (See Ordering Replacement Parts on page 15).

Recommended Spare Parts are shown in red. Charted are item numbers and part descriptions. When ordering use example below.

Example: Need a replacement Return Roller Bracket for a 450BOS.

Part No: SN 123456 - 2 - 1.9 Return Roller Bracket



# MODEL 450BOS END DRIVE, END SIDE MOUNT DRIVE & CENTER DRIVE DRAWINGS

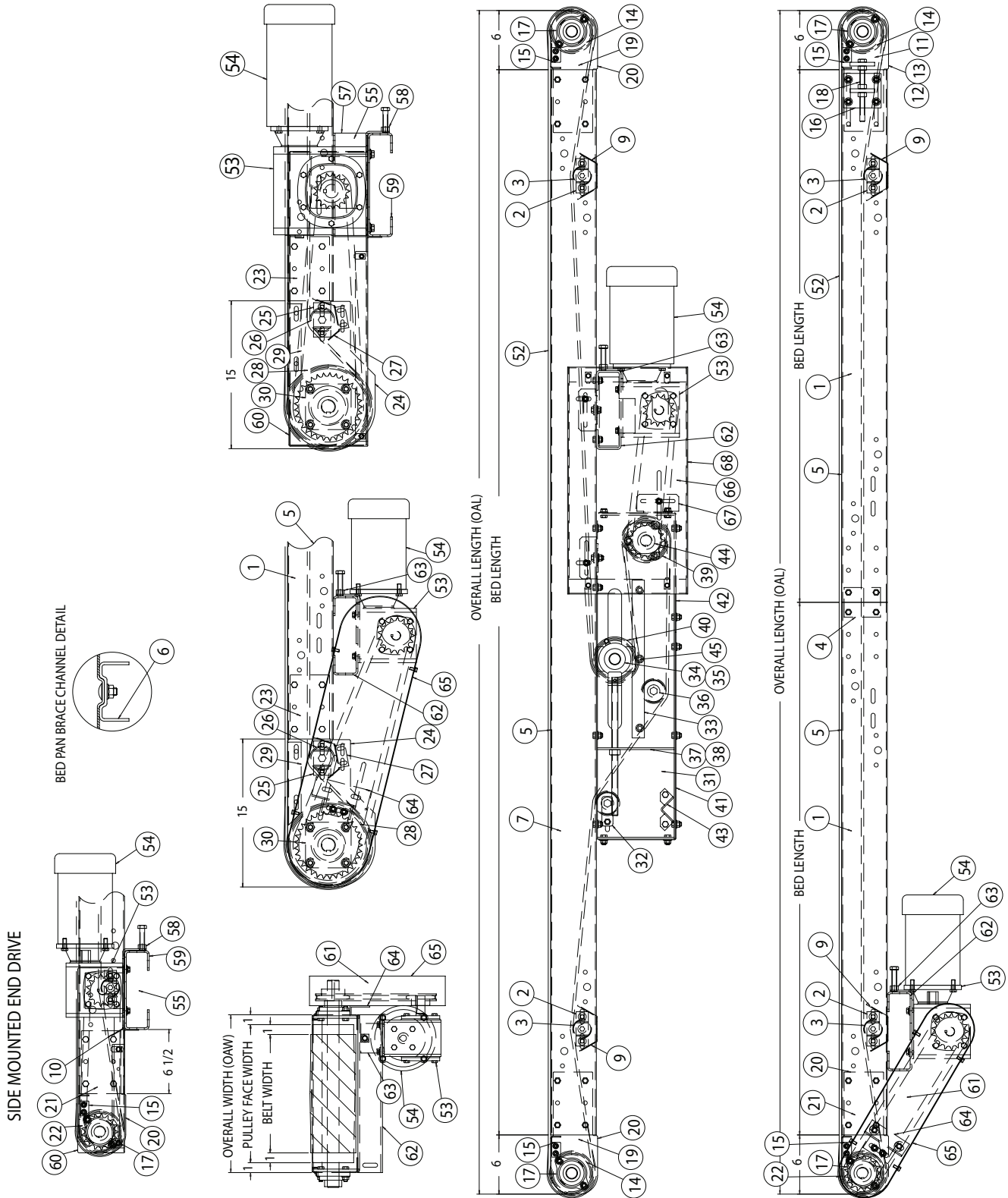

**! WARNING**

Use connector bracket with safety pop out roller to permanently attach gravity conveyor sections to 450BOS

# MODEL 796RB PARTS LIST

ITEM #	DESCRIPTION	ITEM #	DESCRIPTION
1	796RB Intermediate Bed Section	26	6" Fixed & End Drive Plate (LH/RH)
2	1.9 Roller Keeper	27	Filler Pan
3	Splice Plate	28	4 Hole Flange Bearing w/1-7/16" Bore (BRW04070)
4	196S Roller Assembly	29	4" End Drive Assembly
5	Side Channel (12"-120")	30	Safety Pop-Out Roller Assembly
6	Frame Crossbrace	31	Bearing Take-Up Mounting Angle
7	4" End Take-Up Assembly	32	Bearing Push Plate
8	Take-Up Bearing Assembly	33	Bed Pan Brace (For 27"BF and above)
9	Safety Pop-Out Roller Assembly	34	Bed Joint Mounting Angle
10	4" Take-Up Bearing Guide	35	4" Drive Pulley Assembly
11	Bolt-In Butt Coupling	36	4" Fixed & End Drive Plate (LH/RH)
12	4" Take-Up Bed Joint (Left Hand/Right Hand)	37	Filler Pan
13	4" Take-Up Filler Pan Assembly	38	2 Hole Flange Bearing w/1-3/16" Bore (BRW04014)
14	4" Idler Pulley Assembly	29	6" Drive End Assembly
15	196S Roller Assembly	30	Safety Pop-Out Roller Assembly
16	4" Take-Up Plate (LH/RH)	31	Bearing Take-Up Mounting Angle
17	Bearing Guide Spacer	32	Bearing Push Plate
7	6" End Take-Up Assembly	33	Bed Pan Brace (For 27"BF and above)
8	Take-Up Bearing Assembly	34	Bed Joint Mounting Angle
9	Safety Pop-Out Roller Assembly	35	6" Drive Pulley Assembly
10	6" Take-Up Bearing Guide	36	6" Fixed & End Drive Plate (LH/RH)
11	Bolt-In Butt Coupling	37	Filler Pan
12	6" Take-Up Bed Joint Angle (LH/RH)	38	4 Hole Flange Bearing w/1-7/16" Bore (BRW04070)
13	6" Take-Up Filler Pan Assembly	29	8" End Drive Assembly
14	6" Take-Up Idler Pulley Assembly	30	Safety Pop-Out Roller Assembly
15	—	31	Bearing Take-Up Mounting Angle
16	6" Take-Up Plate (LH/RH)	32	Bed Pan Brace (For 27"BF and above)
17	Bearing Guide Spacer - 5/16" Flat Washer	33	Bearing Push Plate
18	Top take-Up Bearing Guide	34	Bed Joint Mounting Angle
19	4" Fixed End Assembly	35	8" Drive Pulley Assembly
20	Safety Pop-Out Roller Assembly	36	8" Fixed & End Drive Plate (LH/RH)
21	Bearing Take-Up Mtg. Angle	37	Filler Pan
22	Bed Pan Brace (For 27"BF and above)	38	4 Hole Flange Bearing w/1-7/16" Bore (BRW04070)
23	Bearing Push Plate	39	2.5 Roller Keeper
24	Bed Joint Mounting Angle	40	Belt Guard (LH/RH)
25	4" Idler Pulley Assembly	41	Snub Roller Belt Guard
26	4" Fixed & End Drive Plate (LH/RH)	42	251S Roller Assembly
27	Filler Pan	43	196S Tread Roller Assembly
28	2 Hole Flange Bearing w/1-3/16" Bore (BRW04014)	44	4" Center Drive Assembly
19	6" Fixed End Assembly	45	2.5 Roller Keeper
20	safety Pop-Out Roller Assembly	46	Center Drive Take-Up Bearing Guide
21	Bearing Take-Up Mounting Angle	47	Take-Up Bearing Assembly (LH/RH)
22	Bed Pan Brace (For 27"BF and above)	48	251S Roller Assembly
23	Bearing Push Plate	49	4" Center Drive Plate Weld Assembly (LH/RH)
24	Bed Joint Mounting Angle	50	4" Drive Pulley Assembly
25	6" Idler Pulley Assembly		



# MODEL 796RB

## PARTS LIST CONT. (DRAWINGS ON NEXT PAGE)

ITEM #	DESCRIPTION	ITEM #	DESCRIPTION
51	4" Idler Pulley Assembly	44	12" Center Drive Assembly w/6" or 8" Take-Up Pulley
52	4" Center Drive Belt Guard	45	Bearing Push Plate (LH/RH)
53	4" Center Drive Belt Guard	46	Center Drive Take-Up Bearing Guide
54	Frame Crossbrace	47	Take-Up Bearing Assembly w/1-7/16" Bore (A26253)
55	3 Hole flange Bearing w/1-3/16" Bore (BRW04040)	48	4" Idler Pulley Assembly
44	8" Center Drive Assembly	49	12" Center Drive Plate Weld Assembly (LH/RH)
45	2.5 Roller Keeper	50	12" Drive Pulley
46	Center Drive Take-Up Bearing Guide	51	6" Idler Pulley Assembly
47	Take-Up Bearing Assembly (LH/RH)	52	12" Center Drive Belt Guard
48	251S Roller Assembly	53	12" Center Drive Belt Guard
49	8" Center Drive Plate Weld Assembly (LH/RH)	54	Frame Crossbrace
50	8" Drive Pulley Assembly	55	4 Hole Flange Bearing w/1-15/16" Bore (BRW04080)
51	4" Idler Pulley Assembly	56	3 Hole Flange Bearing w/1-3/16" Bore (BRW04040)
52	8" Center Drive Belt Guard	57	Belting Assembly
53	8" Center Drive Belt Guard	58	Motor
54	Frame Crossbrace	59	Motorbase Stiffener Assembly
55	4 Hole Flange Bearing w/1-7/16" Bore (BRW04070)	60	Reducer Push Plate Assembly
44	12" Center Drive Assembly w/4" Take-Up Pulley	61	Sidemount Motorbase Plate
45	Bearing Push Plate (LH/RH)	62	Sidemount Chain Guard Assembly
46	Center Drive Take-Up Bearing Guide	63	Reducer
47	Take-Up Bearing Assembly (LH/RH)	64	Chain Guard Angle Mount (LH/RH)
48	4" Idler Pulley Assembly	65	Underneath Motorbase Plate
49	12" Center Drive Plate Weld Assembly (LH/RH)	66	Chain Guard Assembly
50	12" Drive Pulley	67	Center Drive Chain Guard Assembly
51	4" Idler Pulley Assembly		
52	12" Center Drive Belt Guard		
53	12" Center Drive Belt Guard		
54	Frame Crossbrace		
55	4 Hole Flange Bearing w/1-15/16" Bore (BRW04080)		
56	3 Hole Flange Bearing w/1-3/16" Bore (BRW04040)		

Specify **Unit Serial Number** when ordering replacement parts to ensure proper allocation of components (See Ordering Replacement Parts on page 15).

**Recommended Spare Parts are shown in red. Charted are item numbers and part descriptions.** When ordering use example below.

Example: Need a replacement 6" End Take-up Assembly for a 796RB.  
Part No: SN 123456 - 7 - 6" End Take-up Assembly



# MODEL 796RB

## END DRIVE, END SIDE MOUNT DRIVE & CENTER DRIVE DRAWINGS

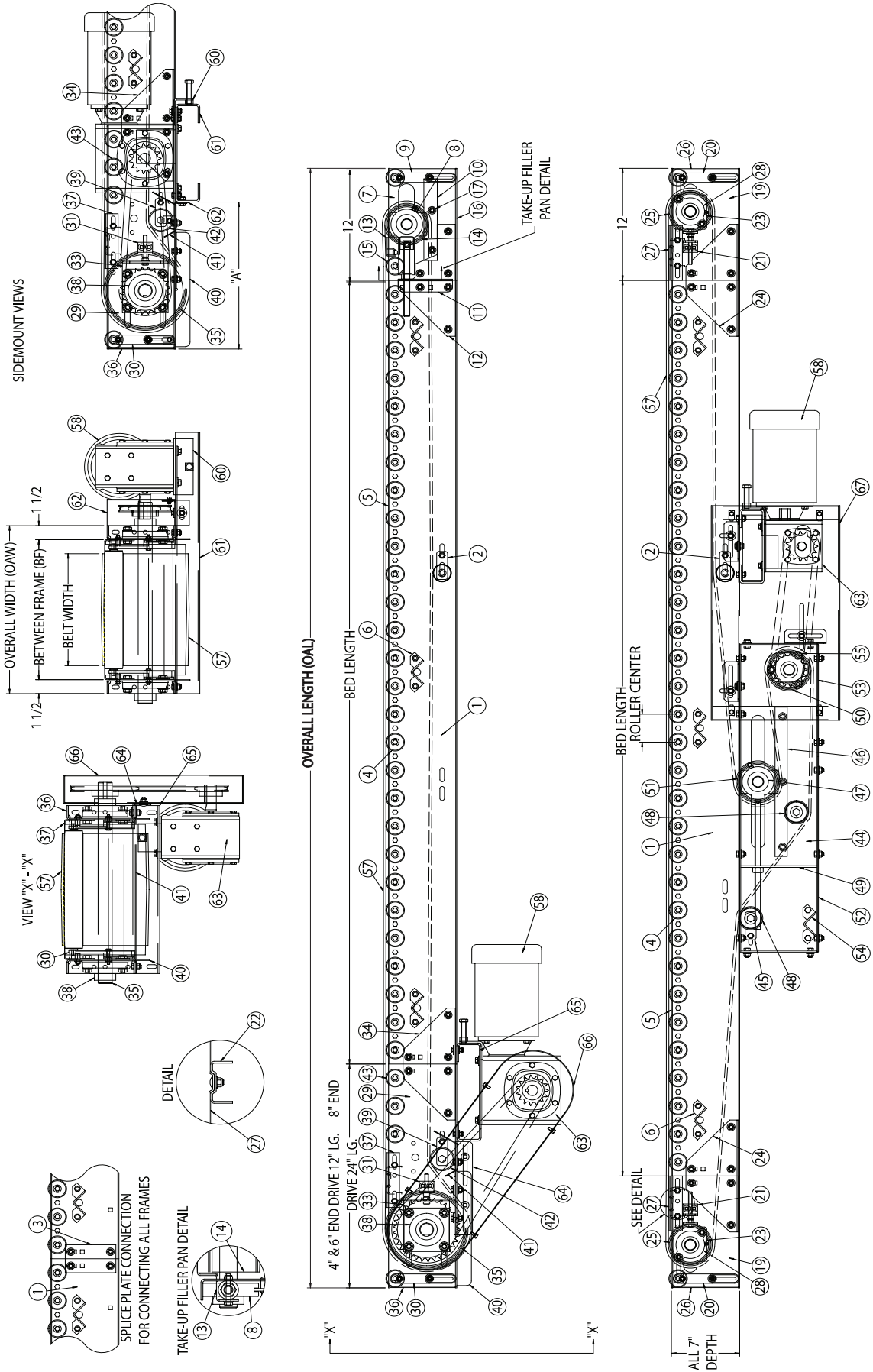

# MODEL 751RB PARTS LIST

ITEM #	DESCRIPTION	ITEM #	DESCRIPTION
1	751 RB Intermediate Bed Assembly	27	6" Fixed & End Drive Plate
2	1.9 Roller Keeper	28	Filler Pan
3	Splice Plate	29	4 Hole Flange Bearing w/1-7/16" Bore (BRW04070)
4	251S Roller Assembly	30	8" End Drive Assembly
5	196S Roller Assembly	31	Safety Pop-Out Roller Assembly
6	Heavy Duty Side Channel 12"-120"	32	Bearing Take-Up Mounting Angle
7	Frame Crossbrace	33	Bed Pan Brace (27" BF & Above)
8	4" End Take-Up Assembly	34	Bearing Push Plate
9	Take-Up Bearing Assembly	35	Bed Joint Mounting Angle
10	Safety Pop-Out Roller Assembly	36	8" Drive Pulley Assembly
11	4" Take-Up Bearing Guide	37	8" Fixed & End Drive Plate
12	Bolt-In Butt Coupling	38	Filler Pan
13	4" Take-Up Bed Joint Mounting Angle	39	4 Hole Flange Bearing w/1-7/16" Bore (BRW04070)
14	4" Take-Up Filler Pan Assembly	40	2.5 Roller Keeper
15	4" Idler Pulley Assembly	41	Belt Guard
16	251S Roller Assembly	42	Roller Belt Guard
17	4" Take-Up Plate	43	251S Roller Assembly
18	Bearing Guide Spacer	30	12" End Drive Assembly
8	6" End Take-Up Assembly	31	Safety Pop-Out Roller
9	Take-Up Bearing Assembly	32	Bearing Take-Up Mounting Angle
10	Safety Pop-Out Roller Assembly	33	Bed Pan Brace (27" BF & Above)
11	6" Take-Up Bearing Guide	34	Bearing Push Plate
12	Bolt-In Butt Coupling 6" Take-Up	36	12" Drive Pulley Assembly
13	6" Take-Up Bed Joint Mounting Angle	37	12" Fixed & End Drive Plate
14	6" Take-Up Filler Pan Assembly	38	Filler Pan
15	6" Idler Pulley Assembly	39	4 Hole Flange Bearing w/1-15/16" Bore (BRW04080)
17	6" Take-Up Plate	40	2.5 Roller Keeper
18	Bearing Guide Spacer (5/16" Flat Washer)	42	Snub Roller Belt Guard
19	Top Take-Up Bearing Guide	43	251S Roller Assembly
20	4" Fixed End Assembly	44	4" Center Drive Assembly
21	Safety Pop-Out Roller Assembly	45	2.5 Roller Keeper
22	Bearing Take-Up Mounting Angle	46	Center Drive Take-Up Bearing Guide
23	Bed Pan Brace (27" BF & Above)	47	(Milled) Take-Up Bearing Assembly
24	Bearing Push Plate	48	251S Roller Assembly
25	Bed Joint Mounting Angle	49	4" Center Drive Plate Weld Assembly
26	4" Idler Pulley Assembly	50	4" Drive Pulley Assembly
27	4" Fixed & End Drive Plate	51	4" Idler Pulley Assembly
28	Filler Pan	52	4" Center Drive Belt Guard
29	2 Hole Flange Bearing w/1-3/16" Bore (BRW04014)	53	4" Center Drive Belt Guard
20	6" Fixed End Assembly	54	Frame Crossbrace
21	Safety Pop-Out Roller Assembly	55	3 Hole Flange Bearing w/1-3/16" Bore (BRW04040)
22	Bearing Take-Up Mounting Angle	44	8" Center Drive Assembly
23	Bed Pan Brace (27" BF & Above)	45	2.5 Roller Keeper
24	Bearing Push Plate	46	Center Drive Take-Up Bearing Guide
25	Bed Joint Mounting Angle	47	(Milled) Take-Up Bearing Assembly
26	6" Idler Pulley Assembly	48	251S Roller Assembly

# MODEL 751RB

## PARTS LIST CONT. (DRAWINGS ON NEXT PAGE)

ITEM #	DESCRIPTION	ITEM #	DESCRIPTION
49	8" Center Drive Plate Weld Assembly	49	12" Center Drive Plate Weld Assembly
50	8" Drive Pulley Assembly	50	12" Drive Pulley
51	4" Idler Pulley Assembly	51	6" or 8" Idler Pulley Assembly
52	8" Center Drive Belt Guard	52	12" Center Belt Guard
53	8" Center Drive Belt Guard	53	12" Center Belt Guard
54	Frame Crossbrace	54	Frame Crossbrace
55	4 Hole Flange Bearing w/1-7/16" Bore (BRW04070)	55	4 Hole Flange Bearing w/1-15/16" Bore (BRW04080)
44	12" Center Drive Assembly, 4" Take-Up Pulley	56	3 Hole Flange Bearing w/1-3/16" Bore (BRW04040)
45	Bearing Push Plate	57	Belting Assembly
46	Center Drive Take-Up Bearing Guide	58	Motor
47	(Milled) Take-Up Bearing Assembly	59	Motorbase Stiffener Assembly
48	4" Idler Pulley Assembly	60	Reducer Push Plate Assembly
49	12" Center Drive Plate Weld Assembly	61	Sidemount Motorbase Plate
50	12" Drive Pulley	62	Sidemount Chain Guard Assembly
51	4" Idler Pulley Assembly	63	Reducer
52	12" Center Belt Guard	64	Chain Guard Angle Mount
53	12" Center Belt Guard	65	Underneath Motorbase Plate
54	Frame Crossbrace	66	Chain Guard Assembly
55	4 Hole Flange Bearing w/1-15/16" Bore (BRW04080)	67	Center Drive Chain Guard Assembly
56	3 Hole Flange Bearing w/1-3/16" Bore (BRW04040)		
44	12" Center Drive Assembly, 6" or 8" Take-Up Pulley		
45	Bearing Push Plate		
46	Center Drive Take-Up Bearing Guide		
47	Take-Up Bearing Assembly w/1-7/16" Bore (A26253)		
48	4" Idler Pulley Assembly		

Specify **Unit Serial Number** when ordering replacement parts to ensure proper allocation of components (See Ordering Replacement Parts on page 15).

**Recommended Spare Parts are shown in red. Charted are item numbers and part descriptions.** When ordering use example below.

Example: Need a replacement 4" End Take-Up Assembly for a 751RB.

Part No: SN 123456 - 8 - End Take-up Assembly





# MODEL 796RBF

## PARTS LIST

Item #	Description	Item #	Description
1	796RB Intermediate bed assembly	22	Bed pan brace (27" BF & Above)
2	1.9 Roller keeper	23	Bearing push plate
3	splice Plate	24	Bed joint mounting angle
4	196S Roller Assembly	25	6" idler pulley assembly
5	Medium duty side channel 12"-120"	26	6" fixed & end drive plate (LH/RH)
6	Frame crossbrace	27	Filler pan
7	4" end take-up assembly	28	4 hole flange bearing w/1-7/16" bore
8	Take-Up Bearing Assembly	29	4" end drive assembly
9	Safety pop-out roller assembly	30	Safety pop-out roller assembly
10	4" Take-up bearing guide	31	Bearing take-up mounting angle
11	Bolt-in butt coupling	32	Bed pan brace (27" BF and above)
12	4" take-up bed joint mounting angle (LH/RH)	33	Bearing push plate
13	4" take-up filler pan assembly	34	Bed joint mounting angle
14	4" idler pulley assembly	35	4" drive pulley assembly
15	196S roller assembly	36	4" fixed & end drive plate (LH/RH)
16	4" take-up plate (LH/RH)	37	Filler pan
17	Bearing guide spacer	38	2 hole flange bearing w/1-3/16" bore
7	6" end take-up assembly	29	6" drive end assembly
8	Take-Up Bearing Assembly	30	Safety pop-out roller assembly
9	Safety pop-out roller assembly	31	Bearing take-up mounting angle
10	6" Take-up bearing guide	32	Bed pan brace (27" BF and above)
11	Bolt-in butt coupling	33	Bearing push plate
12	6" take-up bed joint mounting angle (LH/RH)	34	Bed joint mounting angle
13	6" take-up filler pan assembly	35	6" drive pulley assembly
14	6" idler pulley assembly	36	6" fixed & end drive plate (LH/RH)
15	196S roller assembly	37	Filler pan
16	6" take-up plate (LH/RH)	38	4 hole flange bearing w/1-7/16" bore
17	Bearing guide spacer	29	8" end drive assembly
18	Top take-up bearing guide	30	Safety pop-out roller assembly
19	4" fixed end assembly	31	Bearing take-up mounting angle
20	Safety pop-out roller assembly	32	Bed pan brace (27" BF and above)
21	Bearing take-up mounting angle	33	Bearing push plate
22	Bed pan brace (27" BF & Above)	34	Bed joint mounting angle
23	Bearing push plate	35	8" drive pulley assembly
24	Bed joint mounting angle	36	8" fixed & end drive plate (LH/RH)
25	4" idler pulley assembly	37	Filler pan
26	4" fixed & end drive plate (LH/RH)	38	4 hole flange bearing w/1-7/16" bore
27	Filler pan	39	2.5 roller keeper
28	2 hole flange bearing w/1-3/16" bore	40	Belt guard (LH/RH)
19	6" fixed end assembly	41	Snub roller belt guard
20	Safety pop-out roller assembly	42	251S roller assembly
21	Bearing take-up mounting angle	43	196S roller assembly (tread)

# MODEL 796RBF

## PARTS LIST

Item #	Description	Item #	Description
44	4" Center drive assembly	49	12" center drive plate weld assembly (LH/RH)
45	2.5 roller keeper	50	12" drive pulley
46	Center drive take-up bearing guide	51	8" idler pulley assembly
47	(milled) take-up bearing assembly (LH/RH)	52	12" center drive belt guard
48	251S roller assembly	53	12" center drive belt guard
49	4" center drive plate weld assembly (LH/RH)	54	Frame crossbrace
50	4" drive pulley assembly	55	4 hole flange bearing w/1-1/15/16" bore
51	4" idler pulley assembly	56	3 hole flange bearing w/1-3/16" bore
52	4" center drive belt guard	57	Single nose over assembly
53	4" center drive belt guard	58	Noseover plate
54	Frame crossbrace	59	7/16" hex washer
55	3 hole flange bearing w/1-3/16" bore	60	11/16" hex washer
44	8" center drive assembly	61	251S roller assembly
45	2.5 roller keeper	62	Snub roller guard
46	Center drive take-up bearing guide	63	196S roller assembly
47	(milled) take-up bearing assembly (LH/RH)	57	Double noseover assembly
48	251S roller assembly	58	Noseover plate
49	8" center drive plate weld assembly (LH/RH)	59	7/16" hex washer
50	8" drive pulley assembly	60	11/16" hex washer
51	4" idler pulley assembly	61	251S roller assembly
52	8" center drive belt guard	62	Snub roller guard
53	8" center drive belt guard	63	196S roller assembly
54	Frame crossbrace	64	Frame crossbrace
55	4 hole flange bearing w/1-7/16" bore	65	Side channel 12" long
44	12" center drive assembly w/4" take-up pulley	66	Belting assembly
45	Bearing push plate (LH/RH)	67	Sidemount drive kit
46	Center drive take-up bearing guide	68	Motorbase stiffener assembly
47	(milled) take-up bearing assembly (LH/RH)	69	Reducer push plate assembly
48	4" idler (snub) pulley assembly	70	Sidemount motorbase plate
49	12" center drive plate weld assembly (LH/RH)	71	sidemount chain guard assembly
50	12" drive pulley	72	End drive kit
51	4" idler pulley assembly	73	Motorbase stiffener assembly
52	12" center drive belt guard	74	Chain guard angle mount (LH/RH)
53	12" center drive belt guard	75	Reducer push plate assembly
54	Frame crossbrace	76	Underneath motorbase plate
55	4 hole flange bearing w/1-1/15/16" bore	77	Chain guard assembly
56	3 hole flange bearing w/1-3/16" bore	78	Center drive kit
44	12" center drive assembly w/6" or 8" take-up pulley	79	Motorbase stiffener assembly
45	Bearing push plate (LH/RH)	80	Reducer push plate assembly
46	Center drive take-up bearing guide	81	Underneath motorbase plate
47	Take-up bearing assembly w/1-7/16" bore	82	Center drive chain guard assembly
48	4" idler (snub) pulley assembly		

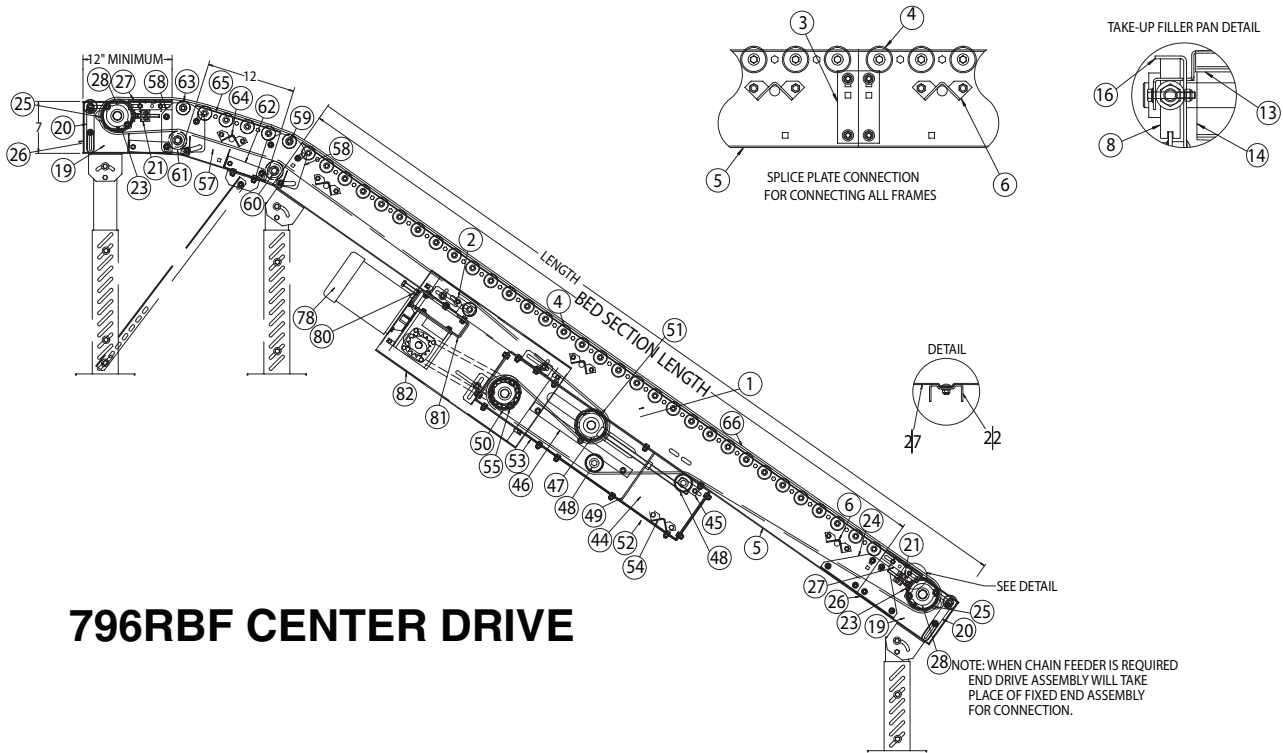

## 796RBF CENTER DRIVE

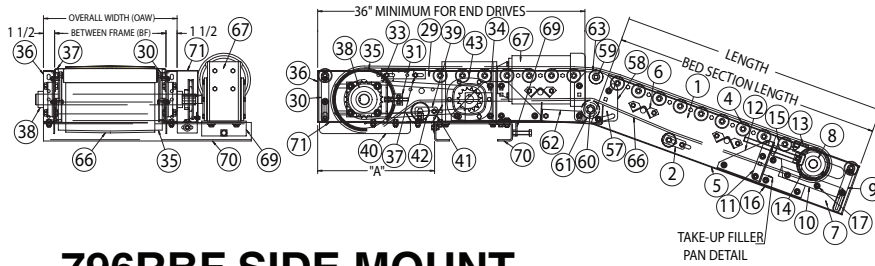

## 796RBF SIDE MOUNT

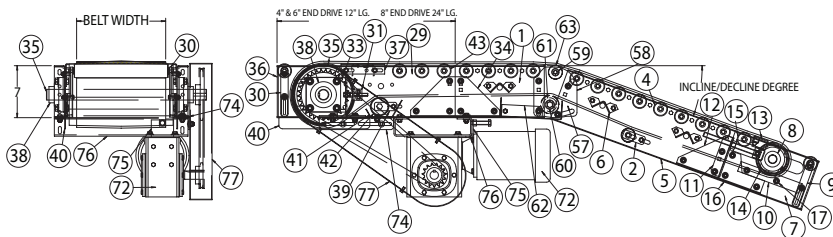

## 796RBF END MOUNT

Specify **Unit Serial Number** when ordering replacement parts to ensure proper allocation of components (See Ordering Replacement Parts on page 15).

Recommended Spare Parts are shown in red. Charted are item numbers and part descriptions.

When ordering use example below.

Example: Need a replacement Center drive it for 796RBF

Part No: SN 123456 - 78 - Center drive kit

	ROACH CONVEYORS 888 HIGHWAY 463 TRUMANN, AR 72472 TEL 870-483-7631
	SERIAL NO.      123456



# MODEL 700SBF

## PARTS LIST

Item #	Description	Item #	Description
1	700Sb intermediate bed assembly	22	Safety pop-out roller assembly
2	1.9 roller keeper	23	Bearing take-up mounting angle
3	Splice plate	24	Bed pan brace (27" BF and above)
4	Bed pan brace (27" and above)	25	Bearing push plate
5	196S roller assembly	26	Bed joint mounting angle
6	Slider bed pan	27	6" idler pulley assembly
7	Medium duty side channel 12"-120"	28	6" fixed & end drive plate (LH/RH)
8	Frame crossbrace	29	Filler pan
9	4" end take-up assembly	30	4 Hole flange bearing w/1-7/16" bore
10	Take-up bearing assembly	31	4" end drive assembly
11	Safety pop-out roller assembly	32	Safety pop-out roller assembly
12	4" take-up bearing guide	33	Bearing take-up mounting angle
13	Bolt-in butt coupling	34	Bed pan brace (27" BF and above)
14	4" take-up bed joint mounting angle (LH/RH)	35	Bearing push plate
15	4" take-up filler pan assembly	36	Bed joint mounting angle
16	4" idler pulley assembly	37	4" drive pulley assembly
17	196S roller assembly	38	4" fixed and end drive plate (LH/RH)
18	4" take-up plate (LH/RH)	39	filler pan
19	Bearing guide spacer	40	2 hole flange bearing w/1-3/16" bore
9	6" end take-up assembly	31	6" drive end assembly
10	Take-up bearing assembly	32	Safety pop-out roller assembly
11	Safety pop-out roller assembly	33	Bearing take-up mounting angle
12	6" take-up bearing guide	34	Bed pan brace (27" BF and above)
13	Bolt-in butt coupling	35	Bearing push plate
14	6" take-up bed joint mounting angle (LH/RH)	36	Bed joint mounting angle
15	6" take-up filler pan assembly	37	6" drive pulley assembly
16	6" idler pulley assembly	38	6" fixed and end drive plate (LH/RH)
17	196S roller assembly	39	filler pan
18	6" take-up plate (LH/RH)	40	4 hole flange bearing w/1-7/16" bore
19	Bearing guide spacer	31	8" end drive assembly
20	Top take-up bearing guide	32	Safety pop-out roller assembly
21	4" fixed end assembly	33	Bearing take-up mounting angle
22	Safety pop-out roller assembly	34	Bed pan brace (27" BF and above)
23	Bearing take-up mounting angle	35	Bearing push plate
24	Bed pan brace (27" BF and above)	36	Bed joint mounting angle
25	Bearing push plate	37	8" drive pulley assembly
26	Bed joint mounting angle	38	8" fixed & end drive plate (LH/RH)
27	4" idler pulley assembly	39	Filler pan
28	4" fixed & end drive plate (LH/RH)	40	4 hole flange bearing w/1-7/16" bore
29	Filler pan	41	2.5 roller keeper
30	2 Hole flange bearing w/1-3/16" bore	42	Belt Guard (LH/RH)
21	6" fixed end assembly	43	Snub roller belt guard
		44	251S roller assembly

# MODEL 700SBF PARTS LIST

Item #	Description	Item #	Description
45	4" center drive assembly	51	12" drive pulley
46	2.5 roller keeper	52	6" or 8" idler pulley assembly
47	center drive take-up bearing guide	53	12" center drive belt guard
48	(Milled) take-up bearing assembly (LH/RH)	54	12" center drive belt guard
49	251S roller assembly	55	Frame crossbrace
50	4" center drive plate weld assembly (LH/RH)	56	4 hole flange bearing w/1-15/16" bore
51	4" drive pulley assembly	57	3 hole flange bearing w/1-3/16" bore
52	4" Idler pulley assembly	58	Single noseover assembly
53	4" center drive belt guard	59	Noseover plate
54	4" center drive belt guard	60	7/16" hex washer
55	Frame crossbrace	61	11/16" hex washer
56	3 hole flange bearing w/1-3/16" bore	62	251S roller assembly
45	8" center drive assembly	63	Snub roller guard
46	2.5 roller keeper	64	196S roller assembly
47	center drive take-up bearing guide	58	Double noseover assembly
48	(Milled) take-up bearing assembly (LH/RH)	59	Noseover plate
49	251S roller assembly	60	7/16" hex washer
50	8" center drive plate weld assembly (LH/RH)	61	11/16" hex washer
51	8" drive pulley assembly	62	251S roller assembly
52	4" Idler pulley assembly	63	Snub roller guard
53	8" center drive belt guard	64	196S roller assembly
54	8" center drive belt guard	65	Bed pan brace (27" BF and above)
55	Frame crossbrace	66	Frame crossbrace
56	4 hole flange bearing w/1-7/16" bore	67	Slider bed pan
45	12" center drive assembly w/4" take-up pulley	68	Side channel 12" long
46	Bearing push plate (LH/RH)	69	Belting assembly
47	Center drive take-up bearing guide	70	Sidemount drive kit
48	(Milled) take-up bearing assembly (LH/RH)	71	Motorbase stiffener assembly
49	4" idler (snub) pulley assembly	72	Reducer push plate assembly
50	12" center drive plate weld assembly (LH/RH)	73	Sidemount motorbase plate
51	12" drive pulley	74	Sidemount chain guard assembly
52	4" idler pulley assembly	75	End drive kit
53	12" center drive belt guard	76	Motorbase stiffener assembly
54	12" center drive belt guard	77	Chain guard angle mount (LH/RH)
55	Frame crossbrace	78	Reducer push plate assembly
56	4 hole flange bearing w/1-15/16" bore	79	Underneath motorbase plate
57	3 hole flange bearing w/1-3/16" bore	80	Chain guard assembly
45	12" center drive assembly w/6" or 8" take-up pulley	81	Center drive kit
46	Bearing push plate (LH/RH)	82	Motorbase stiffener assembly
47	Center drive take-up bearing guide	83	Reducer push plate assembly
48	Take-up bearing assembly	84	Underneath motorbase plate
49	4" idler (snub) pulley assembly	85	Center drive chain guard assembly
50	12" center drive plate weld assembly (LH/RH)		

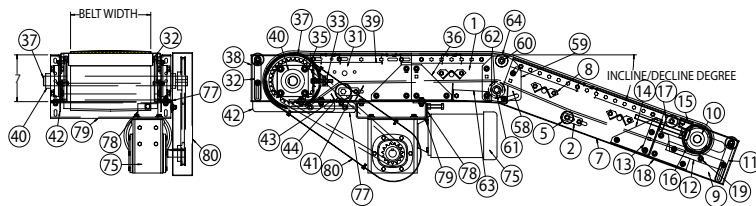
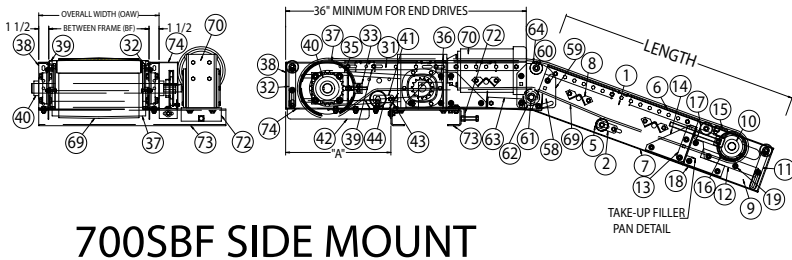
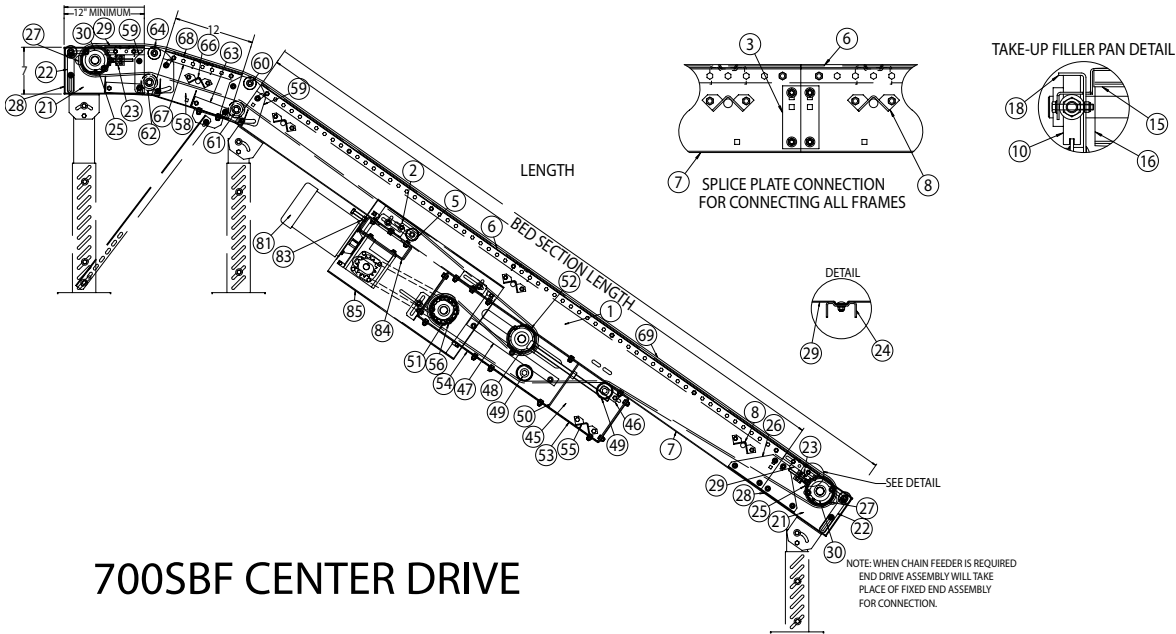

Specify **Unit Serial Number** when ordering replacement parts to ensure proper allocation of components (See Ordering Replacement Parts on page 15).

Recommended Spare Parts are shown in red. Charted are item numbers and part descriptions.

When ordering use example below.

Example: Need a replacement Center drive kit for 700SBF

Part No: SN 123456 - 81 - Center drive kit



ROACH CONVEYORS  
808 HIGHWAY 463  
TRUMANN, AR 72472  
TEL. 870-483-7631

SERIAL NO.      123456

# MODEL BFI INTEGRAL BELT FEEDER PARTS LIST FOR FEEDER (WHEN USED WITH CENTER DRIVE)

Item #	Description	Item #	Description
	2' x 3' Feeder Assembly	27	3/8" hex nut
1	251S roller assembly	28	3/8" nylon insert flange nut
2	4" idler pulley assembly	29	3/8" flat washer
3	Frame crossbrace	30	1/4" steel spring nut
4	Feeder pivot plate left hand		4' through 10' Feeder Assembly
5	Feeder pivot plate right hand	31	251S roller assembly
6	Filler pan (5-7/8")	32	4" idler pulley assembly
7	Bearing take-up mounting angle	33	Feeder pivot plate left hand
8	Bearing push plate	34	Feeder pivot plate right hand
9	Feeder mounting plate	35	Feeder mounting plate
10	Filler pan (17-7/8")	36	Integral feeder belt shield left hand
11	Integral feeder side channel	37	Integral feeder belt shield right hand
12	Integral feeder belt shield left hand	38	Integral feeder pulley guard
13	Integral feeder belt shield right hand	39	2 hole flange bearing 1-3/16" bore
14	Integral feeder pulley guard	40	1/4" - 20 x 1/2" whiz lock screw
15	Bed pan brace channel	41	3/8" x 3/4" long HHCS
16	Safety pop-out roller assembly	42	3/8" x 1" long HHCS
17	Snub roller kit	43	3/8" x 1-1/4" carriage bolt
18	2 hole flange bearing 1-3/16" bore	44	3/8" nylon insert flange nut
19	1/4" - 20 x 1/2" whiz lock screw	45	3/8" flat washer
20	3/8" x 3/4" long HHCS	46	1/4" steel spring nut
21	3/8" x 1" long HHCS	47	Snub roller kit
22	3/8" x 3-1/2" long HHTB	48	4" fixed end assembly
23	5/16" x 3/4" carriage bolt	49	700Sb intermediate bed section
24	3/8" x 3/4" long carriage bolt	50	Squaring rod (short) (796RB)
25	3/8" x 1-1/4" carriage bolt	51	Squaring rod (long) (796RB)
26	5/16" - 18 flange nut	52	Turnbuckle (796RB only)

# MODEL BFI INTEGRAL BELT FEEDER DRAWINGS

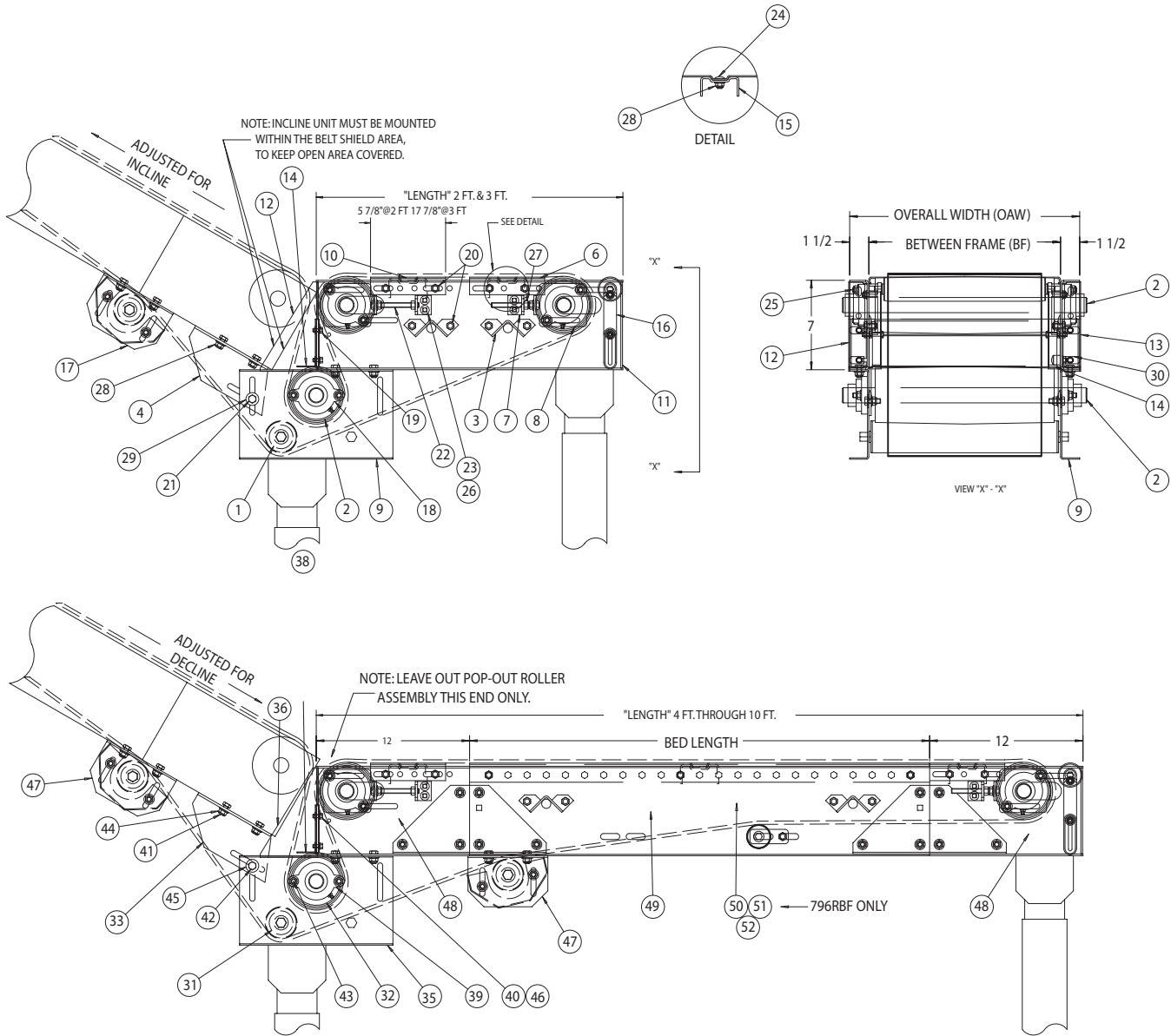

Specify **Unit Serial Number** when ordering replacement parts to ensure proper allocation of components (See Ordering Replacement Parts on page 15).

Recommended Spare Parts are shown in red. Charted are item numbers and part descriptions.

When ordering use example below.

Example: Need a replacement 251S Roller assembly for BFI integral belt feeder

Part No: SN 123456 - 1- 251S Roller Assembly



ROACH CONVEYORS  
808 HIGHWAY 463  
TRUMANN, AR 72472  
TEL 870-483-7631

---

SERIAL NO.      123456

# MODEL BFGD CHAIN DRIVEN FEEDER PARTS LIST FOR FEEDER (WHEN USED WITH CENTER DRIVE)

Item #	Description	Item #	Description
	2' & 3' Feeder Assembly	32	3/8" x 1-1/4" carriage bolt
1	196S roller assembly	33	3/8" x 1-1/2" carriage bolt
2	4' O.D. drive pulley assembly	34	5/16" - 18 flange nut
3	4' O.D. idler pulley assembly	35	5/16" flat washer
4	Chain guard assembly	36	5/16" - 18 nylon insert locknut
5	Belt kits w/assembly instructions	37	3/8" hex nut
6	Frame crossbrace	38	3/8" nylon insert flange nut
7	1.9 roller keeper	39	5/8" - 11 hex nut
8	Filler pan	40	Bearing guide spacer
9	Bolt-in butt coupling	41	#50 chain
10	Bearing take-up mounting angle	42	#50 connector link
11	4" end take-up filler pan	43	Sprocket 1-3/16" bore
12	Bearing push plate		4' through 10' Feeder Assembly
13	Take-up bearing guide	44	Pivot mounting angle left hand
14	Feeder side channel left hand	45	Pivot mounting angle right hand
15	Feeder side channel right hand	46	Pivot mounting plate
16	Pivot mounting angle left hand	47	1/4" SQ x 7/8" long keystick
17	Pivot mounting angle right hand	48	Chain guard assembly
18	Pivot mounting plate	49	Belt kits w/assembly instructions
19	Bed pan brace channel	50	3/8" x 3/4" long HHCS
20	5/8" dia. take-up rod x 6" long	51	3/8" x 1-1/4' long HHCS
21	1/4" SQ x 7/8" long keystick	52	3/8" x 3/4" long carriage bolt
22	Safety pop-out roller assembly	53	3/8" nylon insert flange nut
23	2 hole flange bearing 1-3/16" bore	54	#50 chain
24	1.19" bore milled take-up bearing right hand	55	#50 connector link
25	1.19" bore milled take-up bearing left hand	56	Sprocket 1-3/16" bore
26	5/16" - 18 x 2" hex flange HHCS	57	4" end take-up assembly
27	3/8" x 3/4" long HHCS	58	4" end drive assembly
28	3/8" x 1-1/4" long HHCS	59	700SB intermediate bed section
29	3/8" x 3-1/2" long HHTB	60	Squaring rod (short) (796RB)
30	5/16" x 3/4" carriage bolt	61	Squaring rod (long) (796RB)
31	3/8" x 3/4" long carriage bolt	62	Turnbuckle (796RB only)

# MODEL BFGD CHAIN DRIVEN FEEDER DRAWINGS

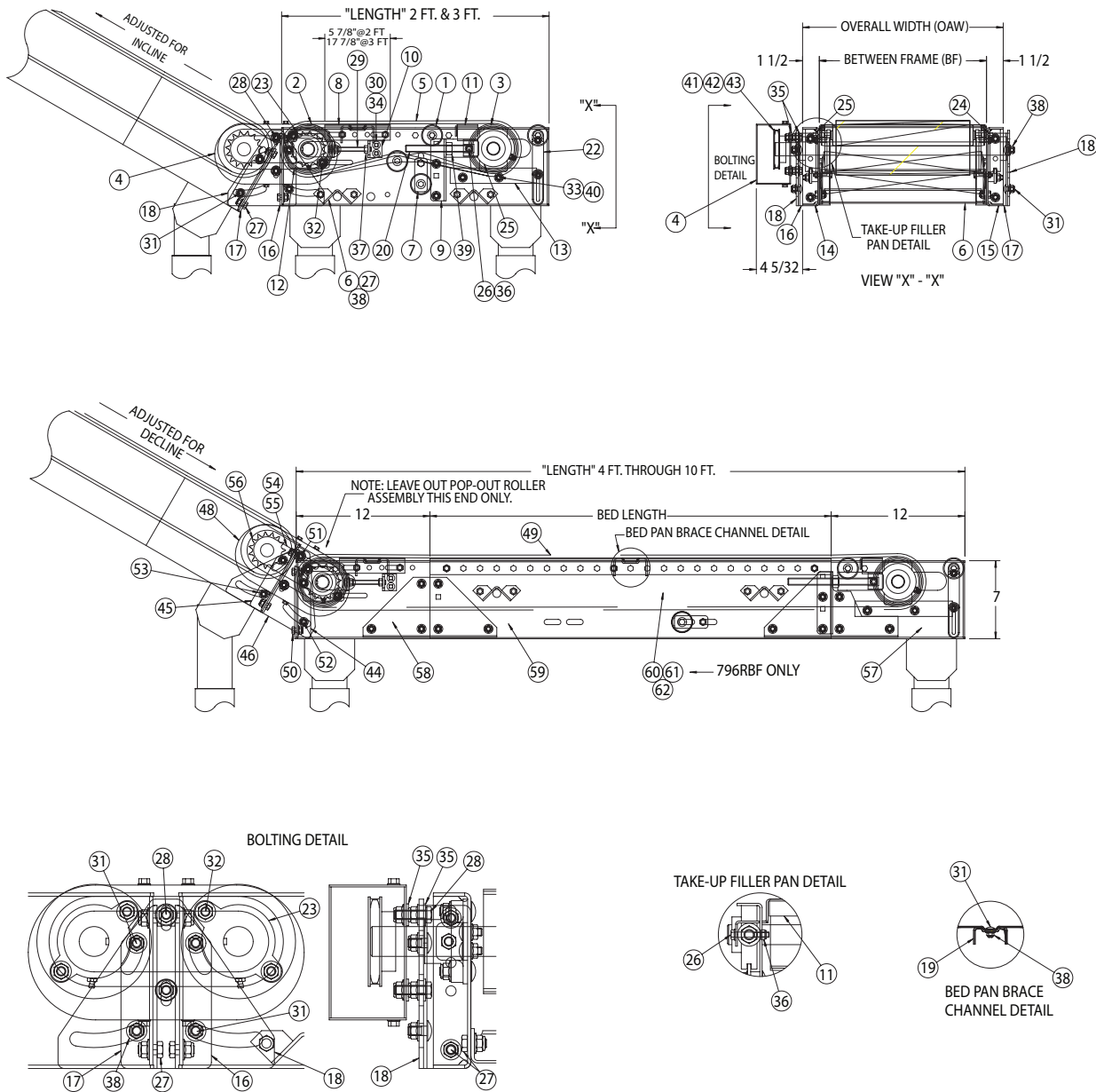

Specify **Unit Serial Number** when ordering replacement parts to ensure proper allocation of components (See Ordering Replacement Parts on page 15).

Recommended Spare Parts are shown in red. Charted are item numbers and part descriptions.

When ordering use example below.

Example: Need a replacement 196S Roller assembly for BFGD Chain driven feeder

Part No: SN 123456 - 1 - 196S Roller Assembly



**ROACH CONVEYORS**  
 808 HIGHWAY 463  
 TRUMANN, AR 72472  
 TEL. 870-483-7631

SERIAL NO.      **123456**



# ROACH CONVEYORS

## WARRANTY

- Materials used by Roach Conveyors are of good quality.
- Any part proving to be defective in materials or workmanship upon Roach inspection, will be replaced at NO cost, FOB, Trumann, Arkansas, for one year. Installation expense will be paid by others.
- Roach liability includes furnishing said part or parts; Roach is not liable for consequential damages, such as loss of profit, delays or expenses incurred by failure of said part or parts.
- Failure due to abuse, incorrect adjustments, exposure to corrosive or abrasive environment or operation under damp conditions does not constitute failure due to defects in workmanship or materials.
- Component parts not manufactured by Roach (motors, gear reducers, etc.) will be repaired or replaced at the option of their manufacturer. Contact nearest authorized service center for all warranty claims.

NOTE: Motors or gear reducers tampered with before inspection shall be considered free of ALL Warranty Claims.

--All specifications are subject to change without notice--  
--Drawings are intended for illustration ONLY and are not to scale--

808 HIGHWAY 463  
TRUMANN, ARKANSAS 72472-1310  
Tel 870-483-7631 Fax 870-483-7049  
sales@roachconveyors.com  
www.roachconveyors.com